

Bridleway Design Manual.

**Guidance notes and design
standards for construction,
alignment, junctions, landscaping
and signing of horse-riding trails
in Milton Keynes.**



2001

Contents page

Section	Title	Page
1.0	Widths	4
2.0	Horizontal Alignment	4
3.0	Vertical Alignment	4
4.0	Visibility	5
5.0	Road/Redway/Footpath Crossing	5
6.0	Shared Surfacing	5
7.0	Pavement Construction	10
8.0	Drainage	10
9.0	Fencing	13
10.0	Landscape	13
11.0	Signing	16
12.0		

INTRODUCTION

1. The development of Milton Keynes incorporates a comprehensive system of horse riding trails. The basic network comprises two routes following the main valleys of the River Ouzel and Loughton Brook, and their surrounding parkland, three cross links within the built up area, and links through the eastern and western flanks to the bridleways in the surrounding countryside. The basic principle underlying these trails is that a specially surfaced route is available for horse riders segregated from footpaths, redways, roads and other routes.

This Design Manual has been prepared in order to advise designers and developers of the standards of construction and other requirements related to the provision of horse trails.

2. Horse trails are an integral part of the Milton Keynes highway system and are to be adopted as bridleways. Approval to detailed design must be obtained from Milton Keynes Council as highway authority with whom suitable arrangements must be entered into for the adoption of trails as bridleways. This arrangement may be part of a general adoption agreement covering all highways within a specific scheme.

POLICY

1. The approved plan showing the “Strategic Horse Trail Network” originally formed part of this manual and more detailed information on routes in the East and West of the city was contained in the District Plans for those areas.
2. The system should be seen as part of a comprehensive network which also includes, in some areas, local roads.
3. All routes should be of a high environmental quality in keeping with the image of an “Attractive City”.
4. Horse trails should connect to bridleway routes outside the designated area of Milton Keynes wherever possible.
5. Landscaping to horse trails should be provided to make the routes attractive and planned to take full account of visibility requirements at junctions and points of connection. The overall aim should be to create an environment that is safe, secure and pleasant.
6. The system should be constructed to standards which are adequate for use by horses and take into account the occasional presence of maintenance vehicles.
7. Adoption and Maintenance: Horse riding trails are to be adopted and maintained as bridleways by Milton Keynes Council. Agreement to this has been reached in principle, but the Council's Rights of Way Section should be consulted on the design of each individual scheme. Developers will be responsible for negotiating adoption arrangements with the Council where appropriate.

HORSE TRAIL – DESIGN STANDARDS

1.0 Widths

- 1.1 Minimum width: 2 metres – 3 metres where heavy use is envisaged (e.g. near stables or riding schools).
- 1.2 Side Clearance:
 - no building or wall or boundary fence (with the exception of a fence dividing a horse trail from a footpath or redway) within 1.0m of the edge of a horse trail;
 - no shrubbery with a mature height of more than 300mm shall be planted within 1.5m of the edge of a trail;
 - in a parkland setting the edge of the trail will merge into the surrounding grassland;
 - all areas shall be accessible to maintenance equipment. In this respect an overall minimum width of 4 metres inclusive of trail and verge is required.

2.0 Horizontal Alignment

- 2.1 6m minimum radius on through routes.
- 2.2 Sharp bends should be avoided along the trail, which should in all cases follow the desire line. Where “short-cuts” are threatened, or right angled turns are provided for, planting or other devices should be provided to deter horses from leaving the trail.

3.0 Vertical Alignments

- 3.1 Steep slopes should be avoided. Gradients should not exceed 5% (1 : 20)
- 3.2 Prevailing slopes of 15% can be accommodated by building steps to reduce their steepness. Risers should not be higher than 150mm, and each step should be at least 3 metres deep to accommodate a standing horse. However, this solution should be avoided if at all possible and, if used, must be agreed with the adopting authority.
- 3.3 Approach gradients to road crossings to provide a 2.5m long platform at gradient not exceeding 1 in 40.
- 3.4 Vertical curves between gradients should not normally be less than 10m and never be less than 2m in length.

4.0 Visibility

- 4.1 The desirable forward visibility is 30m. The minimum forward visibility is 20m.
- 4.2 Junction configurations should be designed so that horse riders do not have to look behind for approaching traffic.
- 4.3 At road crossings the visibility splays shall be provided as follows:
30mph roads: 'x' distance 4.5m 'y' distance 70m.
- 4.4 On roads where speeds are limited to 15mph by use of speed limiting devices this standard could be reduced to 'x' distance 4.5m 'y' distance 35m.
- 4.5 At footpath and redway crossings: 2.5m x 20m.
- 4.6 Shrub planting and other features within the visibility splays must not exceed a mature height of 300mm.

5.0 Road / Redway / Footpath Crossings

- 5.1 An apron 4 metres in length non slip "V" grooved concrete blockwork paving with a 1 metre transitional tongue shall be constructed where a trail meets a road, redway or footpath in order that the loose surface of Hoggin trail is not kicked on to the pedestrian / vehicle surface. (See typical detail).
- 5.2 Where a horse trail crosses a "leisure route" or a low-key footpath the length of "V" grooved block work paving can be reduced to 2 metres either side, together with the 1 metre transitional tongue.
- 5.3 Where a horse trail crosses a new Redway the blockwork common to the horse trail and Redway shall be grey pencil edged concrete blockwork.

6.0 Shared Surfaces

- 6.1 In exceptional circumstances a horse trail may share a surface with a redway. This may occur where a trail is directed along an established route or where a common underpass or bridge is used to cross a city road.
- 6.2 In these circumstances the minimum width for the shared surface is 5 metres to a construction specification suitable for all users and the route must be designated as a "Bridleway".

JUNCTION SIGHT LINES AND VISIBILITY

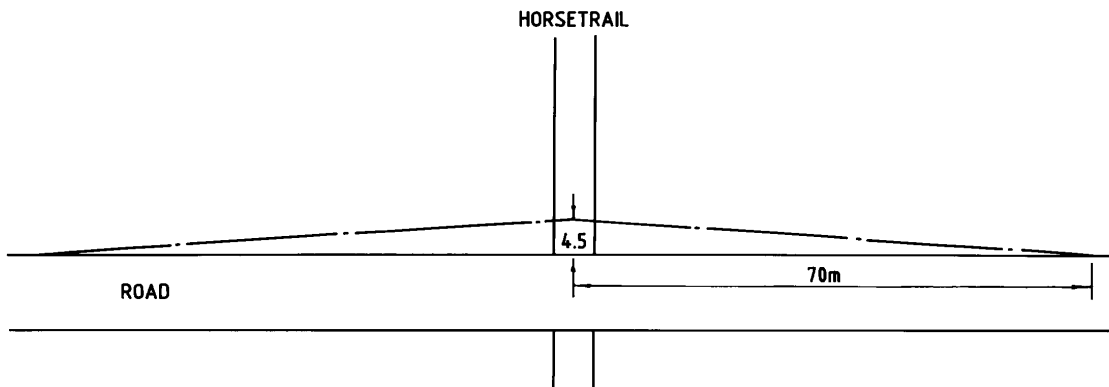

A) ROAD JUNCTION

Where speed is limited to 15mph or road is minor cul-de-sac dimension can be relaxed to 2.5m x 35m.

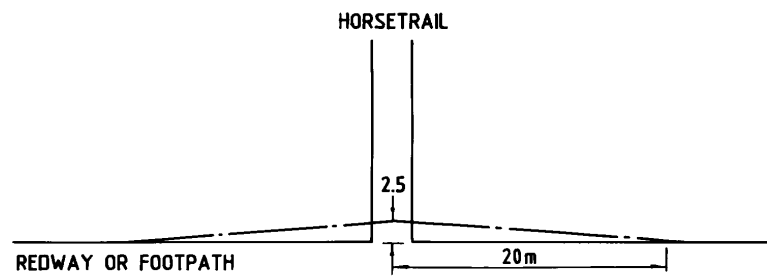

B) REDWAY/FOOTPATH JUNCTION

TYPICAL CORRIDOR LAYOUT FOR
HORSETRAIL AND REDWAY

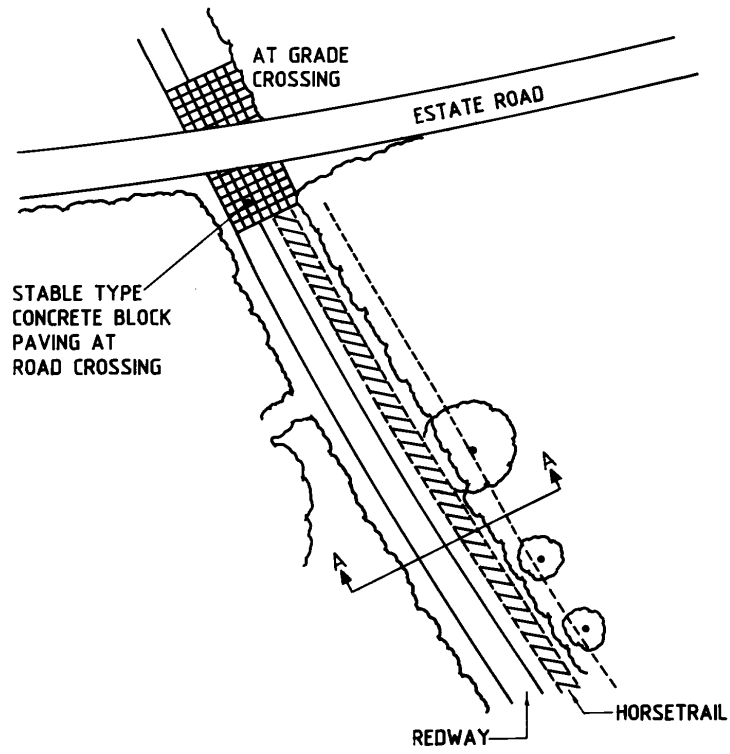

SECTION A-A (N.T.S.)

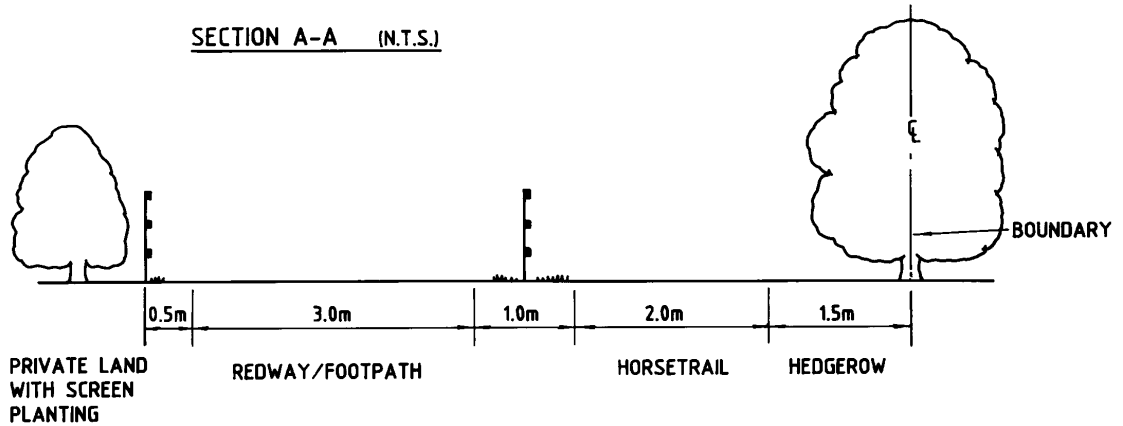

TYPICAL LAYOUT FOR CROSSINGS AND JUNCTIONS

SHEET ONE

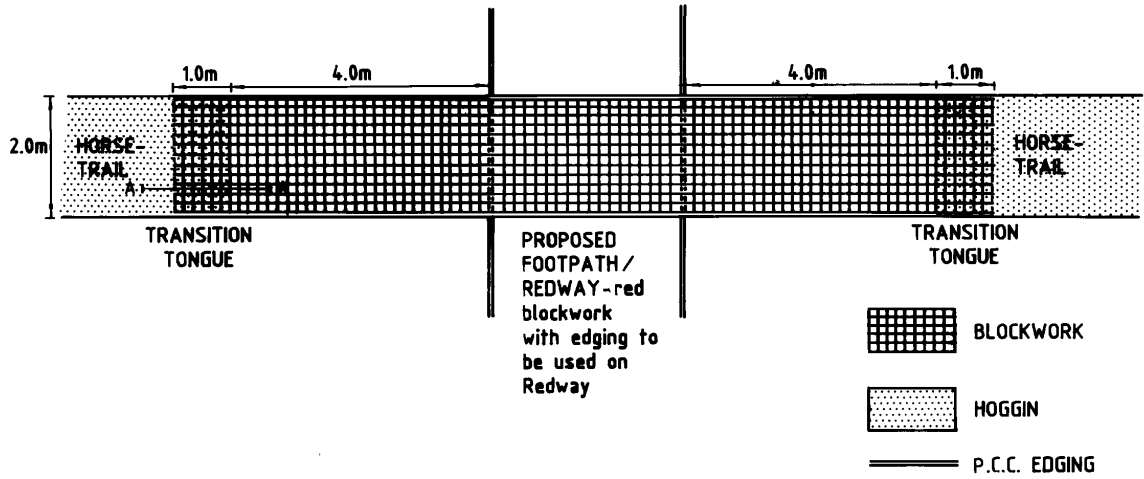
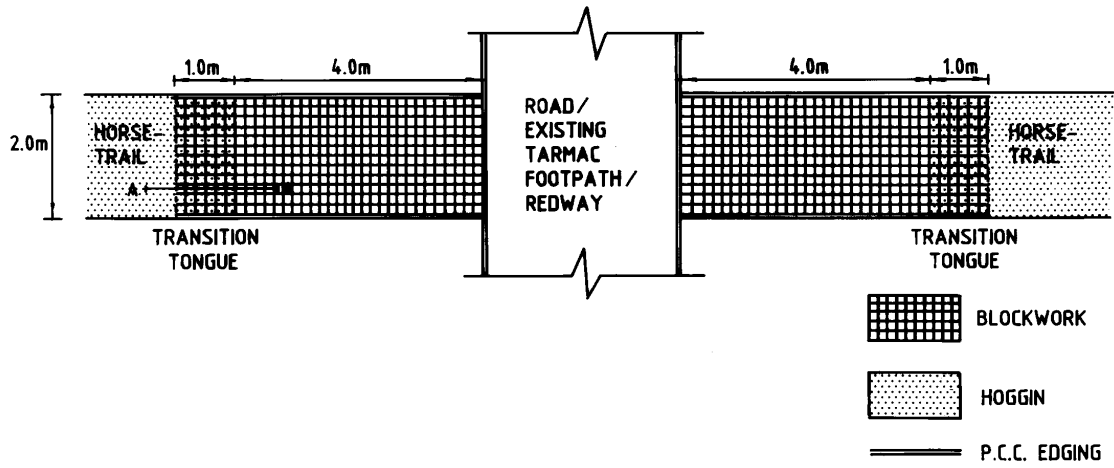

TYPICAL LAYOUTS FOR CROSSINGS AND JUNCTIONS

SHEET TWO

PLAN 1/100

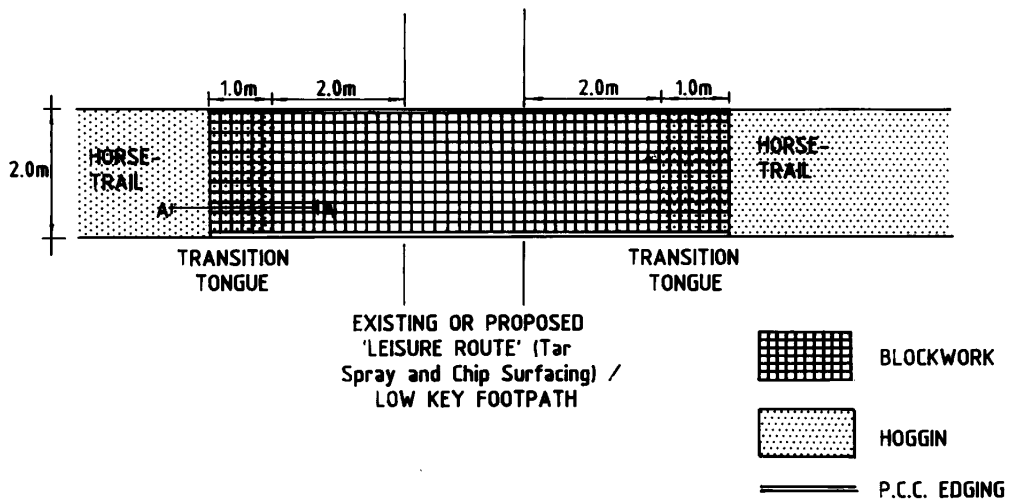
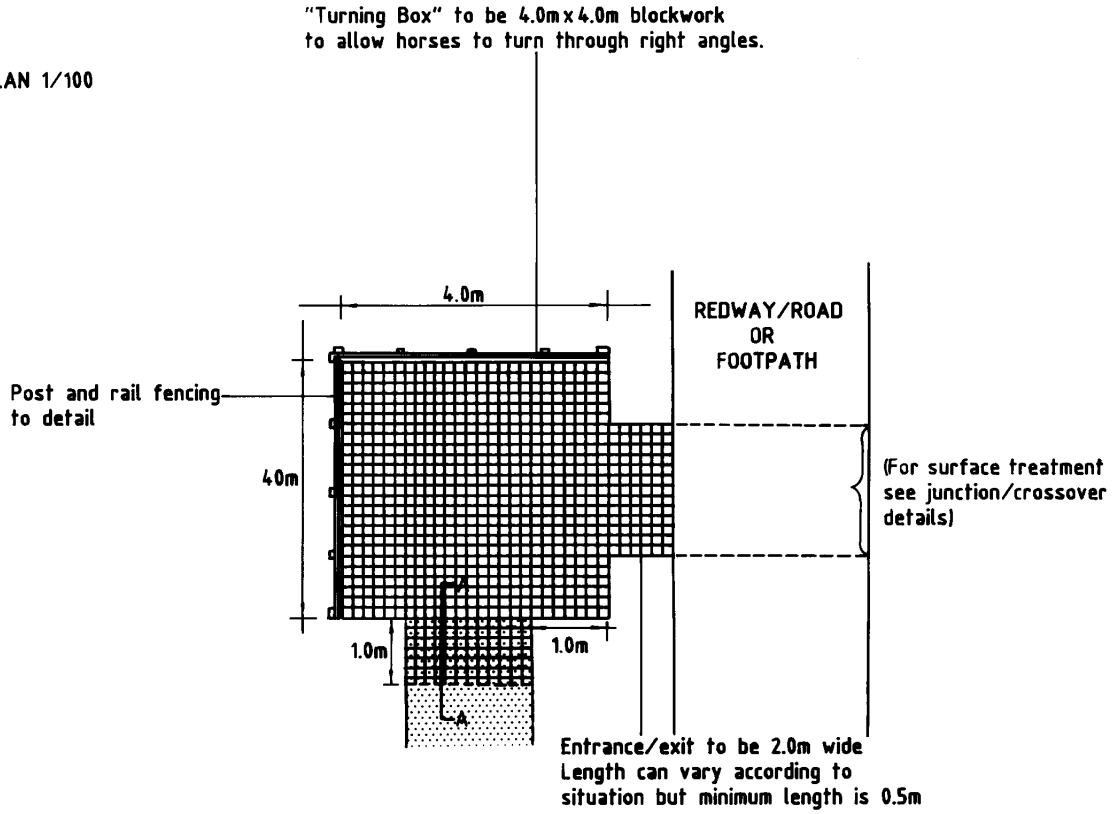

7.0 Pavement Construction

7.1 Horse trails should be constructed to the following specifications:-

Wearing course: 150mm of hoggin

Sub base: 150mm minimum of Type 1 stone sub base.
(Where the formation is found to be soft it may be necessary to increase the thickness of the sub base).

7.2 The formation shall be trimmed to provide a cross fall towards the French drain.

7.3 The surface shall be laid with a domed profile with the finished surface slightly proud of adjacent levels.

Kerbing or timber edge boarding is not required, and shall not be constructed.

7.4 Hoggin shall be a sand gravel mixture, with just sufficient clay for good compaction. Very large or sharp stones that would be retained on a 50mm sieve size should be removed. Local sources of Hoggin are available, which meets this specification.

7.5 Where a section of trail, or an apron at a crossing point is to be constructed in blockwork the specification is:-

- 65mm grey or blue concrete block paving – “V” grooved or pencil edged as described above (5.2 / 5.3)
- 50mm bedding sand.
- 150mm type 1 granular sub base.

8.0 Drainage

8.1 Longitudinal drainage of “French drain” type should be provided as standard along one side of the trail with out falls at every 50 metre intervals. Where wet conditions prevail, additional lateral drainage may be necessary.

8.2 Where a trail is in a cutting there should be a minimum level verge of 1.5 metres either side of the trail. Land drainage should be provided at the toe of the cutting.

8.3 All land drains should connect to an existing land drainage or positive drainage system.

BLOCKWORK PAVEMENT – CONSTRUCTION DETAIL

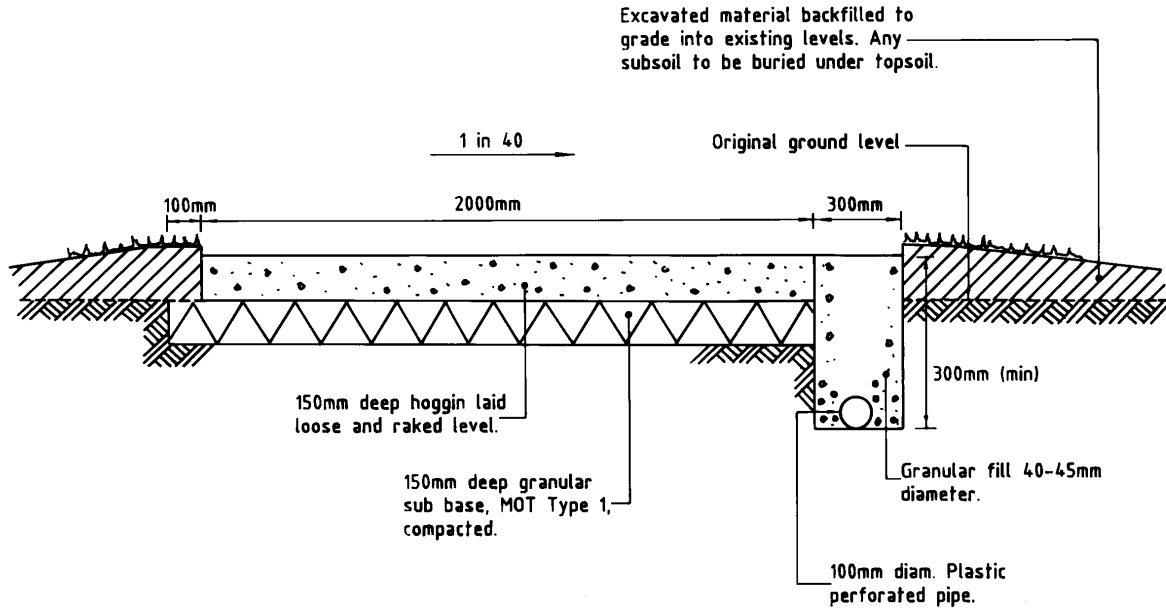

BLOCKWORK PAVEMENT – CONSTRUCTION DETAIL

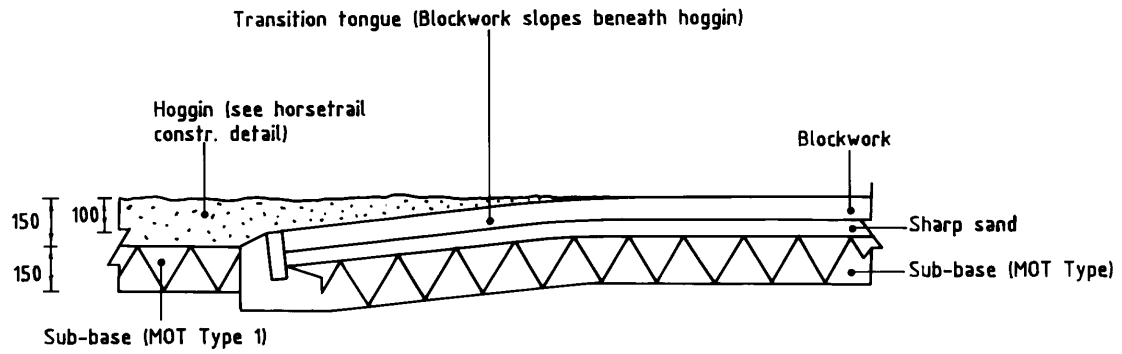

BLOCKWORK DETAIL

1:10 Marshalls "V"-groove block paviors (grey 200x100x65mm). Laid in right angled herringbone. Sharp sand vibrated into joint after laying.

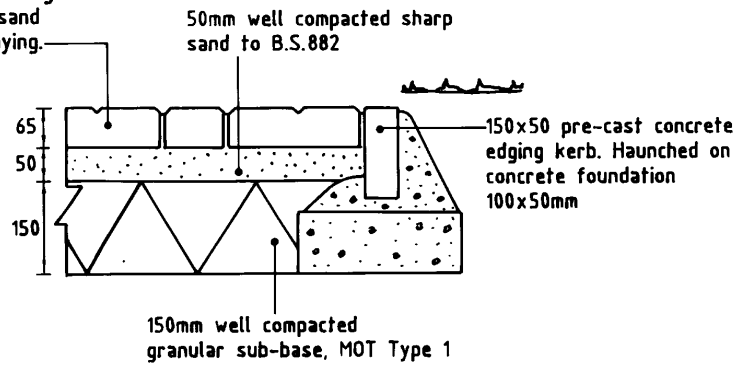

9.0 Fencing

- 9.1 Fences may be necessary in certain circumstances, e.g. against open land, near playing fields, at road crossings, between horse trails and redways or in busy pedestrian areas.

Fencing can also be used to direct horses where routing is not clear.

- 9.2 If a fence is needed as a boundary or as a guidance fence it should normally be a post and rail of 1.1 metres in height, and sufficiently robust to withstand side loading from moving horses. Fences should be constructed of material that will involve a minimum of future maintenance. Suitable material may be timber post and rail or heavy galvanised unpainted iron.
- 9.3 In circumstances where a horse trail is adjacent to a Redway and the central reserve is of the order of 1 metre then it may be appropriate to provide an "ascot" rail fence of 800mm in height.
- 9.4 Arrangements must be made for the transfer of the maintenance responsibility of any fencing to the adjacent landowner or by agreement to the highway authority.

10.0 Landscape

- 10.1 Horse trail landscaping should be provided to make routes attractive and be planned to place emphasis on the visibility requirements at junctions and points of connections (underpasses, bridges and footpaths and redway crossings).
- 10.2 The mature size of planting should be taken into account in designing any planting scheme.
- 10.3 Planting in the visibility envelope at any junction between a bridleway and redway or road should be grass or ground cover with a mature height of less than 300mm. No trees are to be planted within the visibility envelope.
- 10.4 Planting in the verge for a depth of 1.5m either side of a trail should be grass or ground cover with a mature height of less than 300mm.
- 10.5 Where a horse trail and a Redway or footpath are adjacent and the central reservation is of the order of 3 metres and more, the opportunity should be taken to provide suitable central reservation planting including the occasional use of clear stemmed trees.
- 10.6 Spiny, thorny plants – such as roses – should be set well back from the edge of a horse riding trail.
- 10.7 Mounding within the vicinity of a trail should be designed to avoid soil being washed onto the surface of the trail.

STANDARD FENCE DETAIL – POST AND RAIL

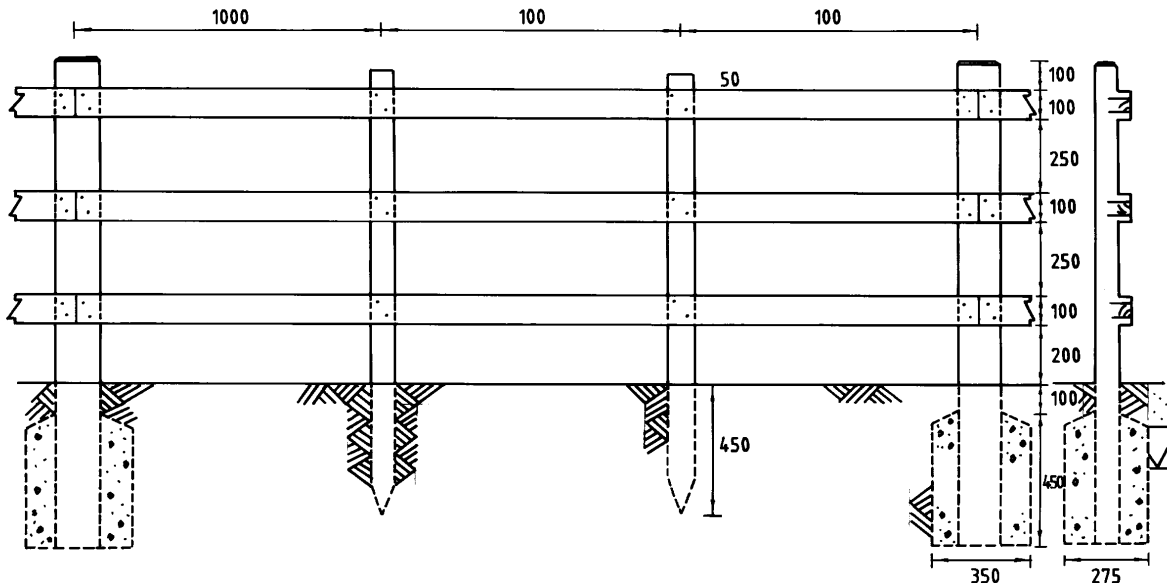

POSTS: 150 x 75 x 1650 at 3000 centres. Top chamfered (10mm) in 4 directions. To be set vertical in holes 350 x 275 x 550 and backfilled with 1:10 concrete to depth shown. When hard, backfill remainder with soil and ram.

INTERMEDIATE

POSTS: 100 x 38 x 1550 with pointed end at 1000 centres. Top chamfered (10mm) in one direction. To be driven in vertically to depth shown. If ground is unsuitable for driving, posts shall be placed in holes 250, 250, 450 and backfilled with 1:10 concrete up to 100mm from surface. When hard backfill remainder with soil and ram.

RAILS: 100 x 38 x 3000. To be butt jointed on centre line of post. Fixed with 75 x 4 and 50 x 3 galvanised annular nails as per drawing.

NOTES: The fence shall be erected true to line and the top of the posts shall follow the mean profile of the ground to give an average height of 1100mm.

Any differences in height due to minor variations in ground profile are accommodated by the depth of dig.

Posts to be erected on side away from horsetrail. Two posts to be used to achieve change in direction if necessary and rails cut accordingly to achieve flush finish.

All timber to be approved Softwood, cut as shown prior to treatment. Softwood to be vacuum pressure treated with copper/chrome/arsenate solution to give 9.6Kg/m D.S.R.

Nails galvanised to B.S.729.

All dimensions in millimetres, unless otherwise stated.

Any staining to be in accordance with Landscape Architects instruction.

STANDARD FENCE DETAIL – ASCOT RAILING

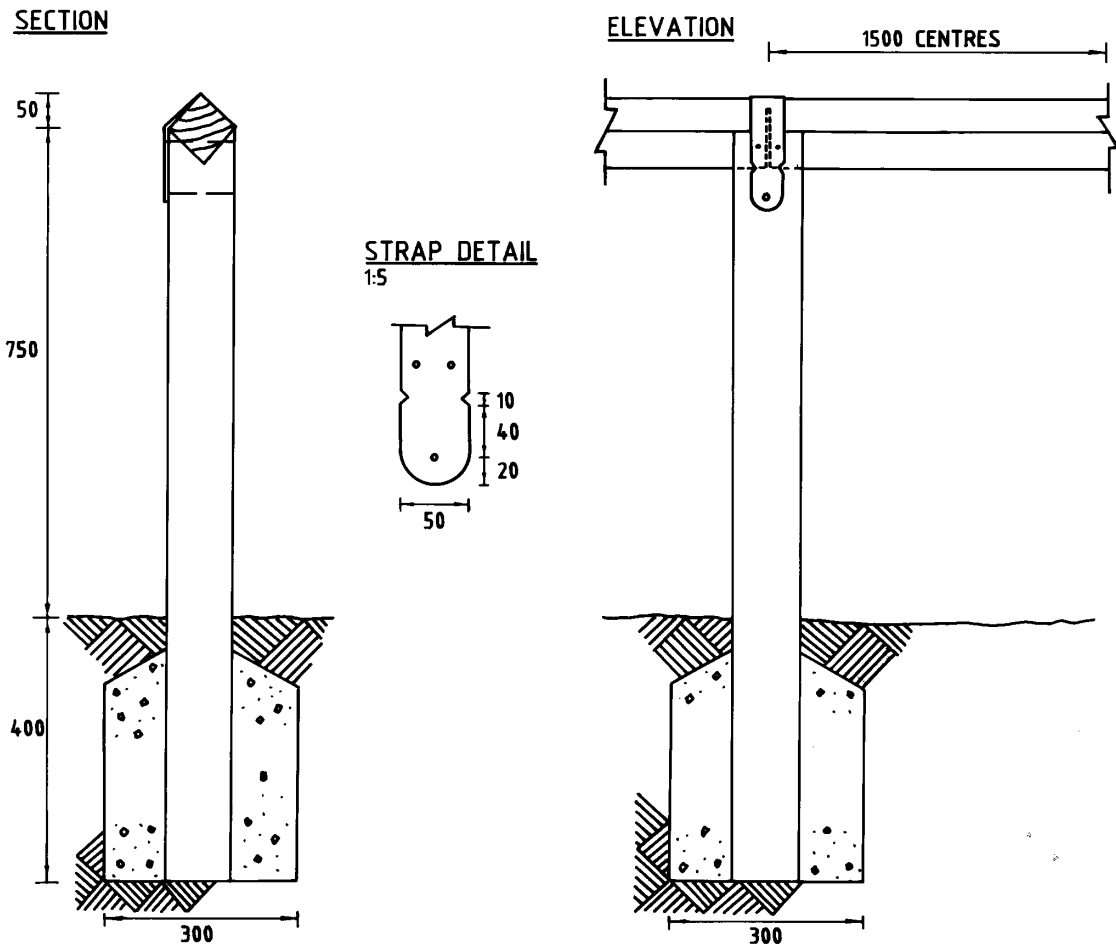

POSTS: 100 x 100 x 1500 at 1500 centres. Top cut as shown to accommodate rail. To be set vertically in holes 300 x 300 and backfilled with concrete as shown. When hard, backfill remainder with soil and ram.

RAILS: 75 x 75 x 3000. To be butt jointed on centre line of post. To be fixed to post with galvanised metal strap (400 x 50 x 1) shaped as shown and 2No. annular nails (40mm) and 1No. round headed screw (40mm), located as shown.

NOTES: The fence shall be erected true to line and the rail shall follow the mean profile of the ground to give an average height of 800mm. Any differences in height due to minor variation in ground profile are accommodated to the depth of dig. Two posts to be used to achieve change in direction if necessary and rails cut accordingly to achieve flush finish.

All timber to be approved Softwood, cut as shown prior to treatment. Softwood to be vacuum pressure treated with copper/chrome/arsenate solution to give 9.6Kg/m D.S.R. All metal galvanised to B.S.729. All dimensions in millimetres. Any staining to be done in accordance with Landscape Architects instructions.

11.0 Signing

Direction and waymarking should be provided where trails diverge, or cross other routes, and at other strategic locations. More information is available from the Rights of Way Section, Milton Keynes Council.

WAYMARKING POSTS

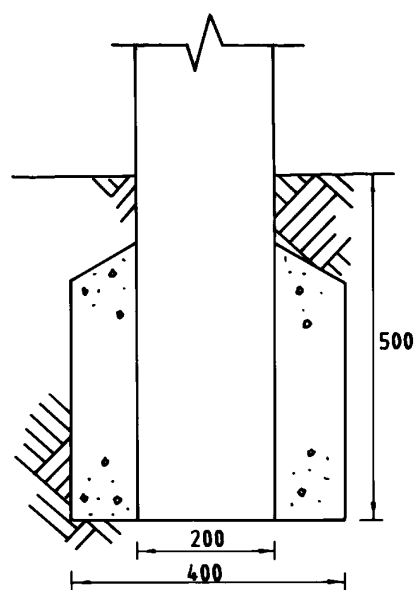
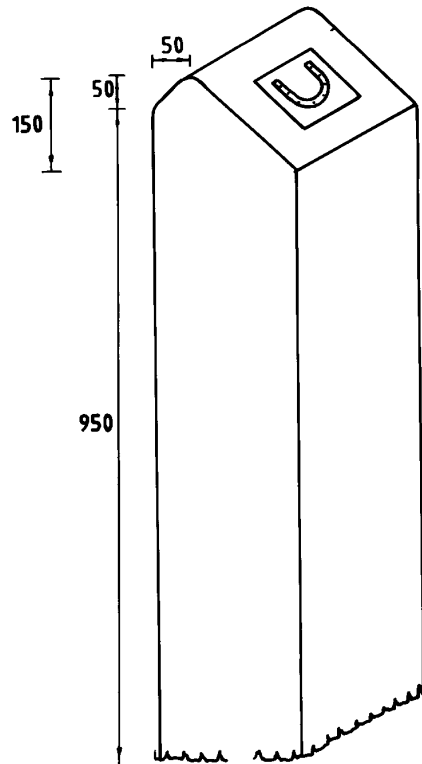

Originally Produced By
Milton Keynes Development Corporation and
Buckinghamshire County Council

