

PLAN

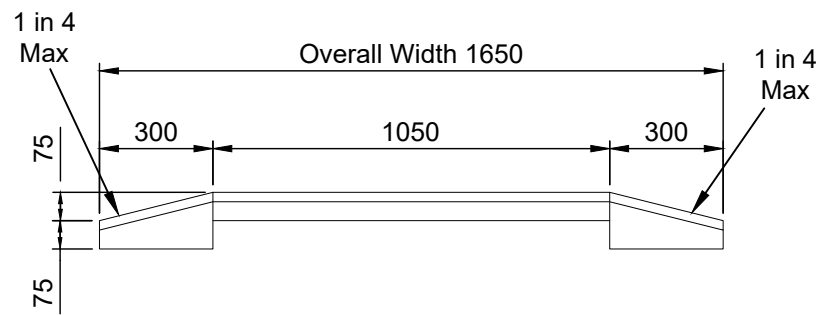

SECTION A-A

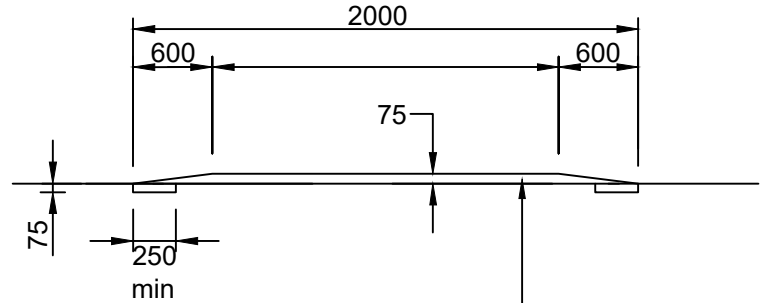

SECTION B-B

40mm Warm Mix Low Void PMB SMA10 (max 5% voids) to BS EN 13108-5 or 50mm HRA 35/14 with 20mm Chips with Class 2 Rut Resistance in accordance with PD 6691.

NOTES

1. All dimensions are in millimetres unless shown otherwise.
2. Position of speed cushions to comply with the Highways (Road Humps) Regulations 1999.
3. Speed cushions should not be positioned alongside gullies.
4. Dimensions, offsets and spacings to be agreed with the MKCC Engineer, following the principles of TAL 4/94 and TAL 2/96.
5. Road markings to refer to the Traffic Signs Regulations and General Directions (TSRGD).
6. Speed Cushions to be permanent asphalt construction.
7. For further information refer to Standard Details Guidance Note drawing no. MKCC-100-001.



Highways and Transportation
Civic Offices
1 Saxon Gate East
Central Milton Keynes
MK9 3EJ

DRAWING TITLE:											
Traffic Calming - Speed Cushions											
SCALE:	REV:		DRAWN:	CHECKED:	APPROVED:	REV:	AMENDMENTS:	DRN:	CHCK'D:	APPR'D:	DATE:
NTS	P01		PG	JM	LS						
		INITIALS:				DRAWING NO:					
		DATE:	07/01/2026	17/03/2026	17/03/2026	MKCC-700-006					

