

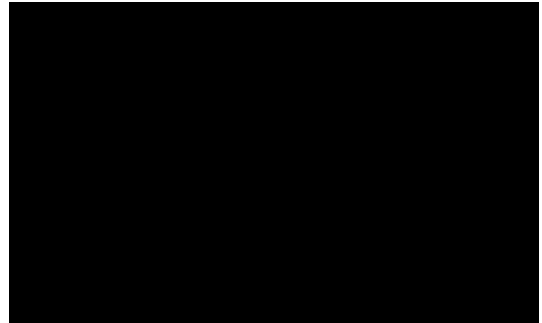

Development Plans
Milton Keynes City Council
Civic, 1 Saxon Gate East
Milton Keynes
MK9 3EJ



By email: ncp.engagement@milton-keynes.gov.uk

Date: 18/12/2025

Dear Sir/Madam,

New MK City Plan 2050 (Regulation 19) Consultation – Response by Network Rail

Background

Milton Keynes City Council (“the Council”) launched their Regulation 19 consultation to the draft MK City Plan 2050 on 7th November 2025, closing on the 22nd December 2025.

This letter sets out Network Rail’s response to the current Local Plan consultation. For ease of reference, the comments follow the order of the draft Local Plan and specify the relevant draft Plan sections, policies, and page numbers.

Network Rail is the statutory undertaker responsible for maintaining and operating the country’s railway infrastructure and associated estate. Network Rail owns, operates, maintains, and develops the main rail network. This includes railway tracks, stations, car parking, signalling systems, bridges, tunnels, level crossings and viaducts.

Network Rail issued initial comments at the start of the local plan process in February 2023, noting that:

- Network Rail would wish to engage as the local plan develops;

- Network Rail encourages policies that support railway enhancements, for both passengers and freight, especially where required for any planned future growth / expansion; and
- Mechanisms for funding necessary railway enhancements should be built into the plan.

Plan Evidence Base

There are several evidence base documents that the Council has identified as being relied upon as part of the preparation of the draft Local Plan. The evidence base is set out on the local plan consultation webpage, with those relating to various aspects of transport including:

- MK Mass Rapid Transit Strategic Outline Business Case Executive Summary (March 2023);
- MK Multi Modal Transport Testing (October 2025);
- MK Multi Modal Transport Model - City Plan Forecast Report (November 2025);
- Milton Keynes Infrastructure Study & Strategy, Infrastructure Study - Initial Assessment Interim Report (May 2024);
- Milton Keynes Infrastructure Study and Strategy Baseline Report (February 2024);
- Milton Keynes Infrastructure Study Further Assessment Report (October 2025); and
- Milton Keynes Infrastructure Delivery Plan (November 2025).

The Milton Keynes Infrastructure Delivery Plan referenced above notes the following rail related long-term policy priorities:

- East-West Rail: Rail link between Oxford and Bletchley, linking to the West Coast Main Line and allowing services from Oxford and potentially Aylesbury onwards towards Milton Keynes Central and Bedford via the Marston Vale Line. Proposals include the provision of two additional platforms;
- New rail link between Bedford and Cambridge;
- New Station entrance at Bletchley;
- Rail investment to support new development in MKISS Sub Area 1 – CMK; and
- Rail Investment to support new Development in MKISS Sub Area 5 – South (Bletchley Railway Station enhancements).

Network Rail is supportive of the main long-term rail priorities listed in the Infrastructure Delivery Plan (and referenced in relevant draft Local Plan policies), although in recognition that rail projects and priorities may evolve over the plan period, it should be noted that other rail projects could emerge and be reflected in any updates to the Infrastructure Delivery Plan and the implementation of Policy INF1 (Infrastructure First Principles).

Additionally, to ensure that the Plan is fully justified through being based on a robust and credible evidence base, it is requested that the Local Plan also specifically identifies Network Rail's West Coast South Strategic Advice document (August 2023) as part of the Plan's evidence base. A copy of the Strategic Advice document is provided with this consultation response, which represents Network Rail's long-term strategic view of how to enhance the West Coast South rail network.

Amongst other things, this Strategic Advice document identifies that the cumulative effect of a range of rail growth and known rail plans, including East West Rail, HS2 and others, will likely increase the strategic importance of Milton Keynes Central as a transport interchange. There will be a significant long-term opportunity to fully integrate the West Coast Main Line South network with the in-development East West Rail (EWR) scheme by extending passenger and freight services, as well as providing a 'hub' for interchange at Milton Keynes, subject to infrastructure improvements being delivered to address capacity constraints.

It should also be noted that more localised studies are being undertaken by Network Rail, working with others in the rail industry to develop long term service proposals as well as infrastructure priorities, including updating information to reflect changing circumstances since the Strategic Advice document was issued.

In this regard, page 15 of the Strategic Advice Note confirms that a more focused piece of strategic advice for the Milton Keynes will be prepared. In addition to the effects of EWR and HS2, the likely creation of Universal Studios in Bedfordshire and other local growth planned for Milton Keynes will further increase the interchange importance of Milton Keynes Central in the immediate future. As such, there will be a collective growth and investment case for short term capacity interventions in Milton Keynes Central and the interchange area around the station, including to increase train service provision and make physical improvements to enhance station capacity to accommodate additional rail traffic and customers. Any proposals in the vicinity of the Station, its surroundings, in immediate proximity to the West Coast Main Line between Milton Keynes Central and Bletchley, and around Bletchley Traction Maintenance Depot and sidings, will need to be reviewed in detail with Network Rail to ensure integration with railway proposals.

Growth Strategy (pp 12 - 17)

Draft Local Plan text at paragraph 5 onwards (pp 12) sets out the key principles of the Plan's growth strategy. These principles include, inter alia:

- *“Taking an ‘infrastructure first’ approach that ensures the necessary facilities (e.g. health, education and community) are provided for our residents as part of development. This includes reflecting the original design principles of the city in delivering new high-quality and accessible green spaces and play areas. We have prepared an Infrastructure Study and Strategy, including an Infrastructure Delivery*

Plan alongside the plan, which is a major element of the evidence base underpinning the strategy. We are also exploring alternative mechanisms which will create new ways of funding and delivering the infrastructure needed to support our city's growth; and

- *Aligning growth with the establishment of a new Metro system that allows people to move around the city with ease, alongside maintaining our grid roads as an integral part of the city's unique design and character. We are preparing an extensive evidence base, and business case, to secure the necessary investment to deliver this network alongside our growth proposals”.*

Network Rail supports a key plan principle based on an ‘infrastructure first’ approach, to ensure that necessary infrastructure is provided as part of development and when it is required. However, the principle, as currently worded, reads as focusing on social and green infrastructure in terms of the types of infrastructure facilities listed. To ensure that the Plan is effective and positively prepared (including by being based on a strategy which seeks to meet objectively assessed requirements), it is recommended that reference to transport infrastructure is also included as part of this principle. Alongside social and green infrastructure, having high quality transport infrastructure in place is vital to supporting the growth ambitions of the area and the Plan’s ‘infrastructure First’ approach.

Spatial Strategy and Proposed Allocations

Draft Policy GS1 (Our Spatial Strategy – p 18) defines the overarching development strategy for Milton Keynes, directing growth according to a settlement hierarchy. The majority of new housing development will be concentrated in the City of Milton Keynes itself, as outlined in draft Policy GS2 (Strategy for Homes – pp 21 - 22).

In line with the overall spatial and growth strategy, the following sites are proposed as strategic allocations for development, which comprise a mix of very large greenfield to smaller-scale brownfield sites. Several of these sites are either close/adjacent to the railway or potentially of a scale large enough to require rail as a sustainable transport mode / a possible need for rail enhancements:

- Wolverton Railway Works Strategic Brownfield Site, mixed-use residential development including 400 homes (Policy GS12);
- Walton Campus Strategic Brownfield Site, mixed-use residential-led development including 400 homes (Policy GS13);
- Eastern Strategic City Extension, mixed-use residential-led development including 16,000 homes (Policy GS14);
- East of Wavendon Strategic City Extension, mixed-use residential-led development including 2,250 homes (Policy GS15);

- South of Bow Brickhill Strategic City Extension, mixed-use residential-led development including 1,300 homes, and segregated routes for active travel and provision of interchange hubs that integrate well with Bow Brickhill Railway Station (Policy GS17);
- Levante Gate Strategic City Extension, mixed-use residential-led development including 1,250 homes (Policy GS18);
- Shenley Dens Strategic City Extension, mixed-use residential-led development including 1,000 homes (Policy GS19);
- Western Expansion Area, 200 for housing and 10 – 20 hectares for employment (Policy GS20);
- Milton Keynes East Strategic Urban Extension, 5,000 houses and 105 hectares of employment land (Policy GS21);
- South East Milton Keynes Strategic Urban Extension, mixed-use residential-led development including 3,000 houses and provision of grade-separated crossings of the railway (Policy GS22); and
- South Caldecotte Strategic Employment Allocation, 195,000sqm of B2 / B8 employment space and direct footpath connections to Bow Brickhill Railway Station (Policy GS23).

So that the Plan is effective and positively prepared, it is requested that Network Rail be provided the opportunity to be fully involved in the implementation of relevant Policies for the proposed Strategic Allocations listed above, including in developing any masterplan or similar that may be prepared, and that, as required, any rail infrastructure requirements (beyond those already identified) are able to be reflected in proposals at an early stage. As noted on page 3 of this letter, in relation to planning for future rail there are strategically significant rail matters to be considered for Milton Keynes Central and surrounding areas such as Bletchley.

Additionally, and in line with comments made to draft Policy GS10 (Movement and Access) below, for any allocations proposing development close to railway infrastructure, appropriate criteria should be added to associated policies to ensure that development does not impact on existing or future rail developments or operations.

Policy GS10: Movement and Access (p 47)

Policy GS10 sets out requirements for new development in terms of movement and access considerations. Criterion 10 of the draft Policy seeks to ensure that the future development or design of adjoining sites is not prejudiced.

In order for the Policy to be wholly consistent with national planning policy, it is recommended that Criterion 10 of Policy GS10 is expanded, or a new criterion added, to ensure that development does not impact on the existing or future operation of the railway in accordance with the 'agent of change' principle established in paragraph 200 of the National Planning

Policy Framework (“NPPF”). The operational requirements of the railway should be safeguarded by ensuring that new development does not impact on the railway or the ability to carry out activities reasonably necessary for its ongoing and future operation (and Network Rail notes that there are proposed allocations close to railway infrastructure – also see responses to other policies below).

Policy CEA8: Provision and protection of accessible open space (pp 172 – 173)

Some of the railway network as shown on the draft Local Plan Policies Map forms part of designated open spaces (specifically linear parks) under draft Policy CEA8. Criterion D of draft Policy CEA8 states that development proposals resulting in the loss of open spaces will only be permitted where:

1. An assessment based on the standards in Annex B and C demonstrates that the existing provision is surplus to requirements; or
2. The lost open space would be replaced with open space of equivalent or better quality, quantity and accessibility in accordance with Annex B requirements.

Network Rail is committed to the protection of accessible open spaces whenever possible, although it is recommended that the following additional text be added as a new point 3 to Criterion D to draft Policy CEA8:

“In the case where a surplus of provision does not exist and replacement open space is not possible in accordance with points 1 and 2 above, development will only be acceptable where it is clearly demonstrated that there is an overriding need for the development that outweighs the loss of open space.”

This additional provision is reflective of the need to ensure the best balance between environmental objectives and the ability to maintain and improve the railway to keep it running safely and smoothly. There can be operational and rail safety considerations that cannot reasonably be addressed in another way that prevent development being designed around the need to incorporate, protect, or enhance existing open spaces and other environmental assets. This change will ensure that the Plan is effective, including in terms of being able to provide for sound infrastructure delivery planning.

Policy CEA9: Biodiversity and habitats network and Policy CEA10: Protection and enhancement of the environmental infrastructure network, priority species and priority habitats (pp 175 – 181)

Draft Policy CEA9 states that development proposals will be strongly supported if they provide a higher than 10% net gain in biodiversity, and those that provide for long-term management

and maintenance for more than 30 years, and those that provide biodiversity enhancements not included as part of the metric.

Criterion C of the Policy notes that whilst habitat loss should be avoided, but that if unavoidable, then proposals must include the creation or enhancement of habitat on-site; the creation of habitat off-site through creation or purchase of units; and/or evidenced purchase of statutory credits where the creation of habitats off-site is not possible.

Draft Policy CEA10 sets out the approach to considering development in the context of different biodiversity designations. This includes international, national and local designations, noting that development will only be permitted in exceptional circumstances, including when the need for development outweighs any unavoidable harm. Criterion G of the Policy states that development proposals will not be permitted unless it has been demonstrated that they will not result in a negative impact upon protected species and priority habitats.

Network Rail supports the approaches adopted in draft Policies CEA9 and CEA10 which acknowledge that there may be exceptional circumstances when the need for development clearly outweighs harm on resources, although for consistency with this approach, a similar provision should also be added to criterion G of draft Policy CEA10.

This overarching approach accords with Network Rail's Biodiversity Action Plan which aims to strike a balance between safety, performance, and environmental outcomes. The importance of the railway for biodiversity, including in connecting habitat networks, is fully recognised, and supported by Network Rail. There is however a need to ensure the best balance between biodiversity objectives and the ability to maintain and improve the railway to keep it running safely and smoothly. It is not always safe or practical to avoid all impacts on existing biodiversity features as part of this balance, and in situations where certain on-site impacts are unavoidable, Network Rail will seek to create appropriate habitats elsewhere, (in the local area where possible), to mitigate for and offset any impacts, also having regard to national planning policy and legislative requirements.

Policy INF1; Infrastructure First Principles; and Policy INF2: Infrastructure planning and delivery principles for strategic allocations (pp 82 – 83)

Draft Policy INF1 (criterion B) requires that the infrastructure needs of development are expected to be addressed through a mixture of on-site provision and / or contributions, as well as through direct negotiations with infrastructure providers where appropriate.

The draft Policy also requires that major development will need to address the broad infrastructure requirements set out in the Infrastructure Delivery Plan. The starting point will be the requirements referenced in INF1.A, considering the latest infrastructure planning

information, including to the Infrastructure Delivery Plan, and the associated infrastructure prioritisation framework.

Draft Policy INF2 requires that to coordinate programmes of infrastructure planning and delivery across Strategic Allocations and Central Milton Keynes in a fair, transparent, and efficient way, the Council will encourage a consistent approach to planning obligations using Section 106 Agreements across all development proposals modelled on an overarching Framework Agreement and allocation-wide Infrastructure Delivery Plan.

Network Rail broadly supports draft Policies INF1 and INF2 which provide a general framework for ensuring that developments make provision for associated necessary infrastructure including through S106, rail and freight projects, also noting the Annex of Infrastructure Delivery Plan (November 2025) and the need to engage with Network Rail in defining project-based requirements. It is reflective of the fact that future growth in the area needs to be supported by appropriate investment in the area's rail network, including from new development which should make provision for associated necessary infrastructure, such as rail and other transport infrastructure, through various appropriate means, including through s106 contributions and CIL. Private sector investment is an important part of the future investment towards improving the area's transit network.

Annex E to the draft Local Plan sets out a proposed Infrastructure Prioritisation Framework, categorising different forms of infrastructure. Rail infrastructure is included in Category C (which is defined as 'a longer-term policy priority'). Whilst this categorisation may be applicable to certain strategic rail projects, improvements may be required as part of / to support planned new growth and development over a shorter timescale. Network Rail therefore requests that rail is also referenced under Category B (mitigation from early occupation), which would also be reflective of the Plan's 'Infrastructure First' approach.

To ensure the effective implementation of these policies, it will be important that the Infrastructure Delivery Plan and the infrastructure prioritisation framework are regularly reviewed to ensure that they accurately reflect current rail (and other) infrastructure requirements. Network Rail would welcome the opportunity to be fully engaged in any review process.

Summary

We trust that these representations are of assistance and that they will be duly considered as part of the local plan process. If you have any queries or require any further information, please do not hesitate to contact me in the first instance.

Yours faithfully,

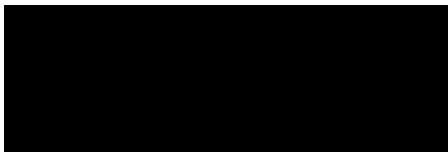

Richard Brown
Senior Director, CBRE (acting on behalf of Network Rail)

Enc: Network Rail West Coast South Strategic Advice Document (August 2023)

Jack Pope

From: [REDACTED]
Sent: 18 December 2025 12:39
To: NCP Engagement
Cc: [REDACTED]
Attachments: MK Plan 2050 Consultation - Comments for Network Rail (18122025).pdf
Categories: Downloaded & saved on SharePoint

You don't often get email from richard.brown3@cbre.com. [Learn why this is important](#)

CAUTION: This email originated outside of Milton Keynes City Council.
Please be extra vigilant when opening attachments or clicking on links.
Report spam or suspected malicious email via the REPORT MESSAGE icon above.

Dear Sirs,

On behalf of our client, Network Rail, please find attached comments made in response to consultation on the Regulation 19 version of the draft MK City Plan 2050. Also included below is a link to Network Rail's West Coast South Strategic Advice document which is referred to in the response letter.

[West Coast South Strategic Advice 2023](#)

I trust that these comments are of assistance and that they will be duly considered as part of the local plan process. If you have any queries or require any further information, please do not hesitate to contact me in the first instance.

I would also be grateful if you could confirm safe receipt of the comments.

Yours faithfully,
Richard

Richard Brown (He/Him)
Senior Director
CBRE | National Planning and Development

[REDACTED] | [LinkedIn](#) | [Twitter](#)

Follow CBRE: [CBRE.com](#) | [LinkedIn](#) | [Twitter](#) | [Instagram](#) | [Facebook](#) | [Weibo](#) | [WeChat](#)

Upcoming leave – from close of business 19th December, returning on 2nd January 2026

We are moving! From Monday 5th January 2026 our new office will be located at 1st Floor, 3 Chamberlain Square, Paradise, Birmingham, B3 3AX.

CBRE Limited, Registered Office: Henrietta House, Henrietta Place, London, W1G 0NB, registered in England and Wales No. 3536032. Regulated by the RICS.

This communication is from CBRE Limited or one of its associated/subsidiary companies.

This communication contains information which is confidential and may be privileged. If you are not the intended recipient, please contact the sender immediately.

Any use of its contents is strictly prohibited and you must not copy, send or disclose it, or rely on its contents in any way whatsoever.

Reasonable care has been taken to ensure that this communication (and any attachments or hyperlinks contained within it) is free from computer viruses.

No responsibility is accepted by CBRE Limited or its associated/subsidiary companies and the recipient should carry out any appropriate virus checks.

Details about the personal data CBRE collects and why, as well as your data privacy rights under applicable law, are available at **[CBRE – Privacy Policy](#)**.

West Coast South Strategic Advice

August 2023



North West
& Central

Contents

ES	Executive Summary	4
1	Document Purpose and Structure	16
2	Objectives and Methodology	22
3	Scope and Assumptions	40
	Geographic Scope	41
	Coventional Network Infrastructure	43
	Rolling Stock and Operations	47
	HS2 and Released Capacity	49
	Conventional Network Schemes in Development	60
4	Planning Principles	66
	Planning Principle A: Supporting Freight Growth	68
	Planning Principle B: Milton Keynes 'Hub'	74
	Planning Principle C: Watford, Milton Keynes, Rugby and Coventry	78
	Planning Principle D: Macclesfield, Stoke-on-Trent and Milton Keynes	81
	Planning Principle E: Stafford, Lichfield, Tamworth, and Nuneaton	84
	Planning Principle F: Shrewsbury and Telford	87
	Planning Principle G: Northampton Service Structure	90
	Planning Principle H: New Stations	94

5	Analysis and Results	98
	Scenario One: Freight Focus	101
	Scenario Two: Intermediate Markets	120
	Scenario Three: East West Connectivity	138
	Scenario Four: New Connections	159
	Scenario Five: Peak Commuter	178
6	Findings and Recommendations	192
	Utilising Released Capacity	193
	Infrastructure Enhancement Priorities	213
	Operator Mapping and Rolling Stock Procurement	240
	Stations	249
	Freight Traction and Gauge Clearance	259
	Decarbonisation	263
	Climate Resilience	265
7	Summary and Further Work	272
A	Appendices	276

Executive Summary

EFES

Key Summary Points

Network Rail's West Coast South Strategic Advice considers how the capacity released by HS2 once phases 1 and 2A (Euston to Birmingham and Crewe) could be used most effectively on the conventional network, and assesses the options for conventional network enhancement which maximise the opportunity presented by released capacity.

The key findings are:

1. Investment in the HS2 infrastructure Euston-Crewe creates a significant opportunity, through the release of conventional network capacity, to improve passenger connectivity and freight capacity on West Coast South in any future scenario provided a basic set of Planning Principles are followed,
2. Maximising the use of this released capacity will require a policy decision on what objective for rail is ultimately prioritised; this is needed to determine what structure of train service is required and consequently what impacts this may have on the wider network, especially in relation to national freight routing,
3. Fully utilising the capacity released by HS2 to serve intermediate (non-HS2 connected) markets into Manchester will be constrained by capacity through the Stockport Corridor; the HS2 infrastructure between Crewe and Manchester must be completed as a minimum to fully realise the benefits associated with released capacity,
4. In all scenarios, the need to use capacity efficiently and connect Milton Keynes as a 'hub' between the West Coast South and East West networks generated a capacity 'bottleneck' between Bletchley and Milton Keynes; this should be a priority for further development to ensure effective and reliable integration of future service changes and to capitalise on the benefits of released capacity,
5. Using capacity effectively in future will also require a sufficient long-term power supply which can support a shift to electric traction, route-wide freight gauge clearances to ensure future freight paths can transport the right types of load, sufficient investment in weather and climate resilience measures, and further exploration of splitting some service groups and redrawing the local operator map to embed longer term operational and rolling stock efficiencies.

Background and Purpose

West Coast Main Line South is one of Britain's most important heavy rail routes. It has historically been one of the busiest mixed-use railways in Europe, serving a range of intercity, interregional and suburban passenger flows as well as offering a nationally significant arterial route for freight. The high intensity of use on this rail corridor, which connects some of Britain's largest urban conurbations, underpins the case for construction of the HS2 network which is required to relieve the at-capacity conventional (i.e. the existing non-HS2 rail infrastructure) route.

Network Rail is obliged to provide advice on the most effective ways to use future network capacity or enhance the infrastructure on the British rail network. This document – West Coast South Strategic Advice (WCSSA) – is a route-wide strategic assessment undertaken for the following overarching purposes:

- To identify and evaluate the opportunities associated with 'released capacity'; namely, utilisation of the capacity that is made available on the conventional network once the longest-distance intercity markets are served by HS2,
- To identify and evaluate where conventional network constraints are likely to persist into the long-term after introduction of HS2 services and offer recommendations on the most credible and effective ways to address them through infrastructure enhancement,
- To provide advice which can be used by specifiers, funder and the industry to guide investment strategies and assure 'strategic fit' for any changes proposed for the intervening period ahead of HS2 introduction.

The scope of this work covers the trunk route for West Coast Main Line South (excluding the St Albans Abbey and Marston Vale branch lines) and assumes a post-HS2 timeframe in which HS2 infrastructure between the new London Euston terminus and Crewe has been delivered. This is the point at which maximum capacity is released on West Coast South route and is available for other uses.

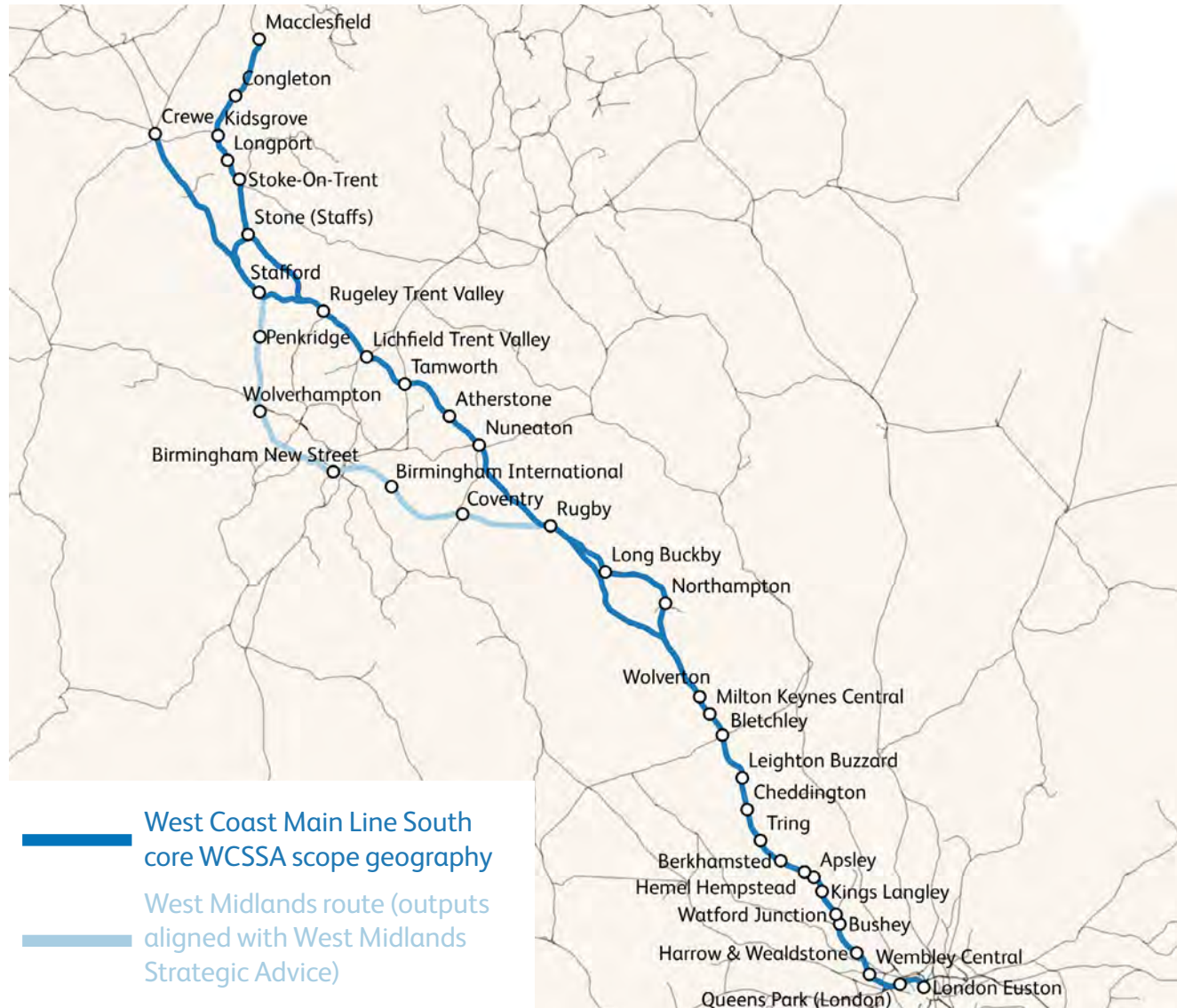

Approach and Method

This document is focused on long-term potential options, assuming delivery of HS2 infrastructure between the new high-speed London Euston station and a connection to the conventional network at Crewe as a minimum. In doing so, it also considers how the release of conventional network capacity will be maximised through completion of the full route to Manchester as committed to in the Government's Integrated Rail Plan. The Strategic Advice does not determine an end-state train service for the post-HS2 period and instead presents the results of a series of Indicative Train Service Specification (ITSS) scenario tests which cover a range of possible uses of capacity on West Coast Main Line South, which can be used to guide future service planning.

The WCSSA analysis explores, within each scenario, how use of released capacity could be maximised, where the infrastructure constraints on the conventional network are, and what credible enhancement options exist to address those constraints over the long-term. The train service scenarios have been tested against a series of overarching objectives with corresponding economic assessment criteria.

Each objective has been used to identify priority markets or flows in the first instance, informing a series of 'Planning Principles' that include minimum operational and service requirements, and which have been factored into all scenarios. The Planning Principles represent a baseline for using released capacity and will constitute Network Rail's advice on developing the post-HS2

conventional timetable in future. This will ensure compatibility between the post-HS2 conventional train service on West Coast South route and the infrastructure options outlined in this document which could then be delivered on an incremental basis in future.

The technical method used to test each scenario has drawn on the expertise of Network Rail's Advanced Timetabling Team (ATT) which provides analytical assurance of long-term network capacity and capability, and Network Rail's Economic Analysis (EA) function which developed the assessment criteria for each of the guiding objectives, and applied them in each scenario. More detail on these methods, the Planning Principles and the results of the analysis is provided in the document.

WCSSA Objectives



Maximise revenue generation through improved journey times, connectivity, and capacity to grow major established passenger flows.



Support development by improving passenger service between locations which are relatively deprived or 'levelling up' target areas.



Encourage modal shift by improving connectivity between locations where there is a clear opportunity to abstract trips from private car to rail.



Stimulate new markets which are currently underserved by rail; connecting communities, generating future revenue and unlocking suppressed demand.



Support freight growth by meeting future demand through provision of expanded capacity and routing options for rail freight.

WCSSA Scenarios

Freight Focus

High growth level of freight with further paths provided via East West Rail and Cannock, and freight given priority.

Intermediate Markets

Uplifted intercity and interregional-type services, connecting major non-HS2 served locations.

East West Connectivity

Provision for new direct connections, with priority given to passenger service extensions from East West Rail.

New Connections

Provision for new direct connections, with priority given to inclusion of eight new stations proposals.

Peak Commuter

A peak-hour scenario which gives priority to suburban-type services into London, de-prioritising southbound freight.

Findings: Utilising Released Capacity

The results of the scenario-based testing generated several key findings, most obviously, the transformational opportunity that HS2 will have on conventional network capability on West Coast Main Line South route. This affirms the Government's aims for HS2 as articulated originally in the 2013 statement of strategic case. Significant improvements in connectivity could be provided for a range of passenger flows, without compromising the potential for uplift in freight provision, as well as retaining a broadly comparable level of service for non-HS2 flows, in all scenarios. The new high-speed infrastructure will act as a major upgrade for the existing conventional network without the disruption and lower level of benefit associated with a route-wide modification programme for the existing route.

There will, however, be some significant trade-offs and issues which require resolution when it comes to allocation of the conventional capacity released by HS2. Focusing network capacity on one set of objectives accordingly limits the ability to fully support another, as well as generating different sets of constraints. A **policy decision** will need to be made on how released capacity should be deployed - whether it should be focused on, for example, maximising benefits for freight, opening up new passenger connections or supporting established markets - in order to effectively plan for impacts elsewhere on the national network.

In all scenarios, there is a clear imperative to support intermediate markets between places on the route which will not

be served directly by HS2 and the major urban conglomerations which will be. This presents an acute and specific difficulty for planning services into Manchester, where HS2 trains are planned to operate for a period on the conventional infrastructure from Crewe. This document reinforces the need to **deliver the HS2 Western Leg infrastructure Euston-Manchester** to generate the full benefit associated with released capacity, as well as considering in further analysis the options for enhancements in the Northwest which could build on the opportunity available through released capacity further south.

There will be a significant long-term opportunity to fully integrate the West Coast Main Line South network with the in-development East West Rail (EWR) scheme by extending passenger and freight services, as well as providing a 'hub' for interchange at Milton Keynes. While this offers the potential to maximise planned investment in EWR, it will generate an **acute capacity constraint between Bletchley and Milton Keynes** limiting the potential for growth across the wider route. As such, it is recommended that no more than two passenger services and one freight service per hour are planned on to West Coast Main Line South via East West Rail until a performance-robust solution can be found or further infrastructure enhancement - in line with this report - is provided. Utilisation of released capacity for more services from East West Rail, whilst possible, consumes a large amount of end-to-end route capacity to deliver a train service over a very short distance between Bletchley and Milton Keynes. There are significant benefits to operating services from East West Rail to Milton Keynes Central and potentially

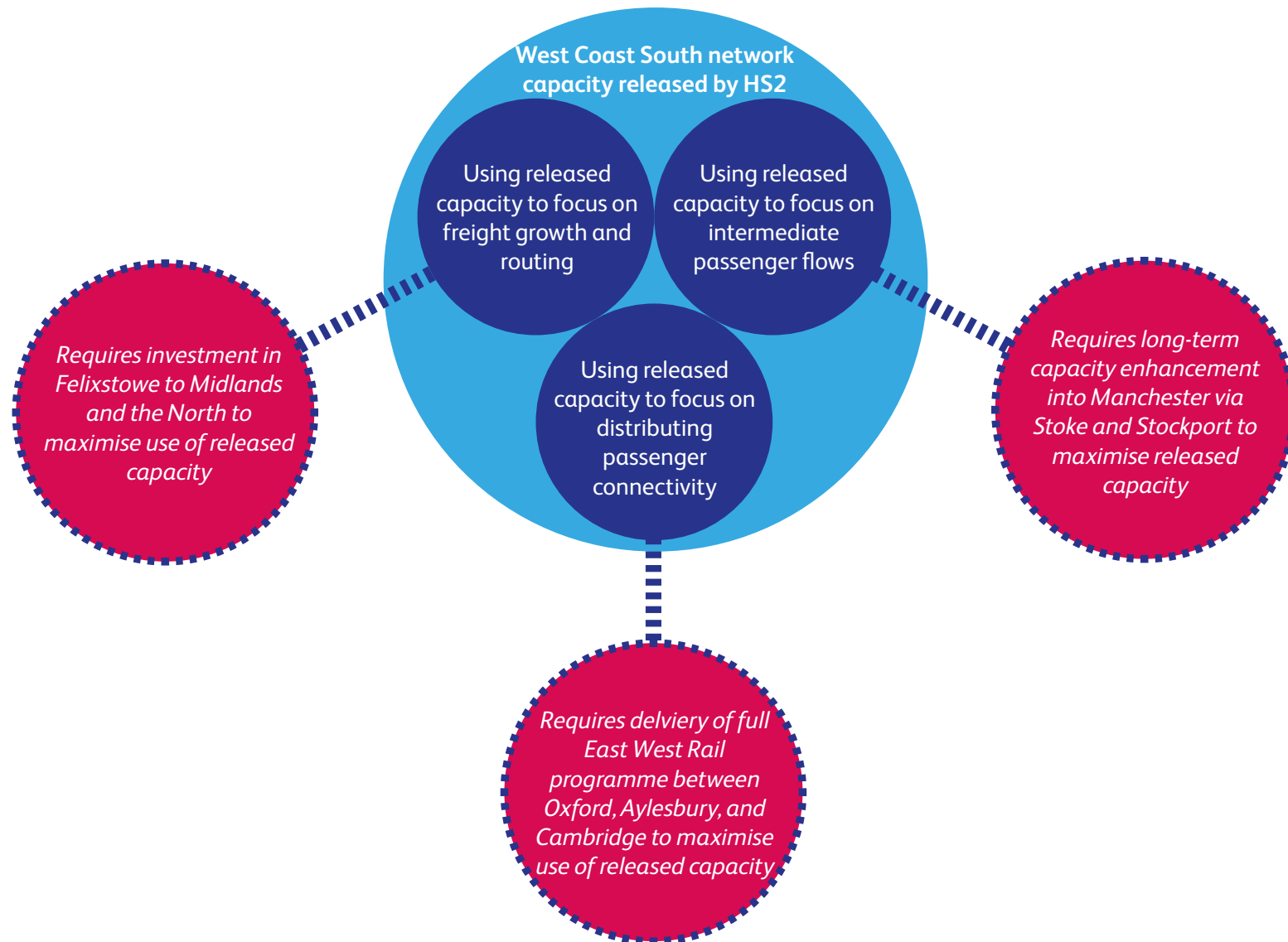

beyond, but these should only be delivered through enhanced infrastructure to avoid negative impacts elsewhere.

Released capacity also presents a major opportunity for freight. The results of the assessment show that it is possible to provide uplift beyond today's level in any scenario. However, focusing use of released capacity for a high growth level of freight will require a combination of the following:

- Trade-off against improvements in passenger service, namely at Northampton where slow line capacity will continue to be constrained,
- Consideration of capacity for additional freight traffic beyond the scope of this study - south of Wembley, north of Crewe, into the West Midlands and via East West Rail - which may present a restriction on the ability to use the WCML to its maximum potential for freight

This Strategic Advice has also considered the potential for released capacity to be used to support a range of new stations proposals. While most included proposals could be accommodated, there is an acute risk to capability and performance for new stations proposals on the heavily constrained part of the route through West Northamptonshire. It is recommended that **no new stations other than the proposed 'Rugby Parkway' station are progressed for delivery in the post-HS2 period on the route section between Milton Keynes and Rugby** until a wider assessment of local stations needs is

undertaken in the Northamptonshire area. Any new stations proposals planned for the pre-HS2 period (before any capacity is released by HS2) will need to be explored on a case-by-case basis, noting that existing capacity constraints are likely to prevent implementation of new stations proposals until HS2 has been delivered.

This document further states that **capacity at the conventional London Euston station is not likely to become a constraint** in the post-HS2 period and that a strong peak service can be provided. The following conditions must be met for this finding to remain valid:

- No more than four trains per hour can operate into London Euston from the DC lines (per today's service level),
- Caledonian Sleeper services continue to operate as they do today, occupying two long platforms across the morning peak hour, with no requirement for single platform operation unless one of the sleeper-length platforms (1 or 15) is out of use,
- If HS2 construction requires removal of Platform 16 at the conventional Euston station it must be re-provided to the same specifications.

Findings: Priorities for Infrastructure Enhancement

The analysis undertaken for this report has also been used to identify, beyond the use of released capacity, where the next infrastructure constraints occur and what enhancement options could address them in each scenario. These results have been compiled collectively, providing a cross-scenario assessment where infrastructure options are evaluated against the following criteria:

- The extent to which an enhancement delivers a material improvement in passenger connectivity or freight uplift, not just an improvement in on-train capacity (i.e. number of seats),
- The extent of train service improvement generated compared to the likely scale and cost of the infrastructure required,
- The extent to which an impact was generated across scenarios, with higher priority ascribed to those which generated a benefit in most or all scenarios,
- The potential for an enhancement to exacerbate known capacity constraints elsewhere, with priority given to 'no regrets' enhancements which require only the existing network infrastructure and delivery of HS2 Euston-Crewe to use,
- The potential for an enhancement to generate a benefit ahead of introduction of high-speed services as well as in the long-term following it.

This document recommends that **the route section between**

Bletchley and Milton Keynes should be the highest priority for further long-term infrastructure enhancement. Addressing this constraint was required in all scenarios with a range of potential service changes possible, more fully integrating the West Coast Main Line and planned East West Rail networks, thereby unlocking further benefits from the investment in both the HS2 and East West Rail programmes.

A second order of infrastructure enhancement options have been identified, including remodelling at Coventry and Nuneaton and providing fast line freight loops between Rugby and Milton Keynes, which could generate significant benefit but were scenario specific. These should be developed further should the train service outputs they unlock become a future priority.

This document also identified two further categories of enhancement:

- *Untested* enhancement options which were smaller in scale and could provide a benefit, but were not identified as requirements in any scenario and could therefore be progressed on a case-by-case basis,
- *Unrequired* enhancements comprised of major track changes and grade separation projects which could eventually be beneficial but would exacerbate wider network constraints and are therefore unlikely to generate a useable benefit.

These further options have been included alongside those prioritised for any further development within the findings section of this report.

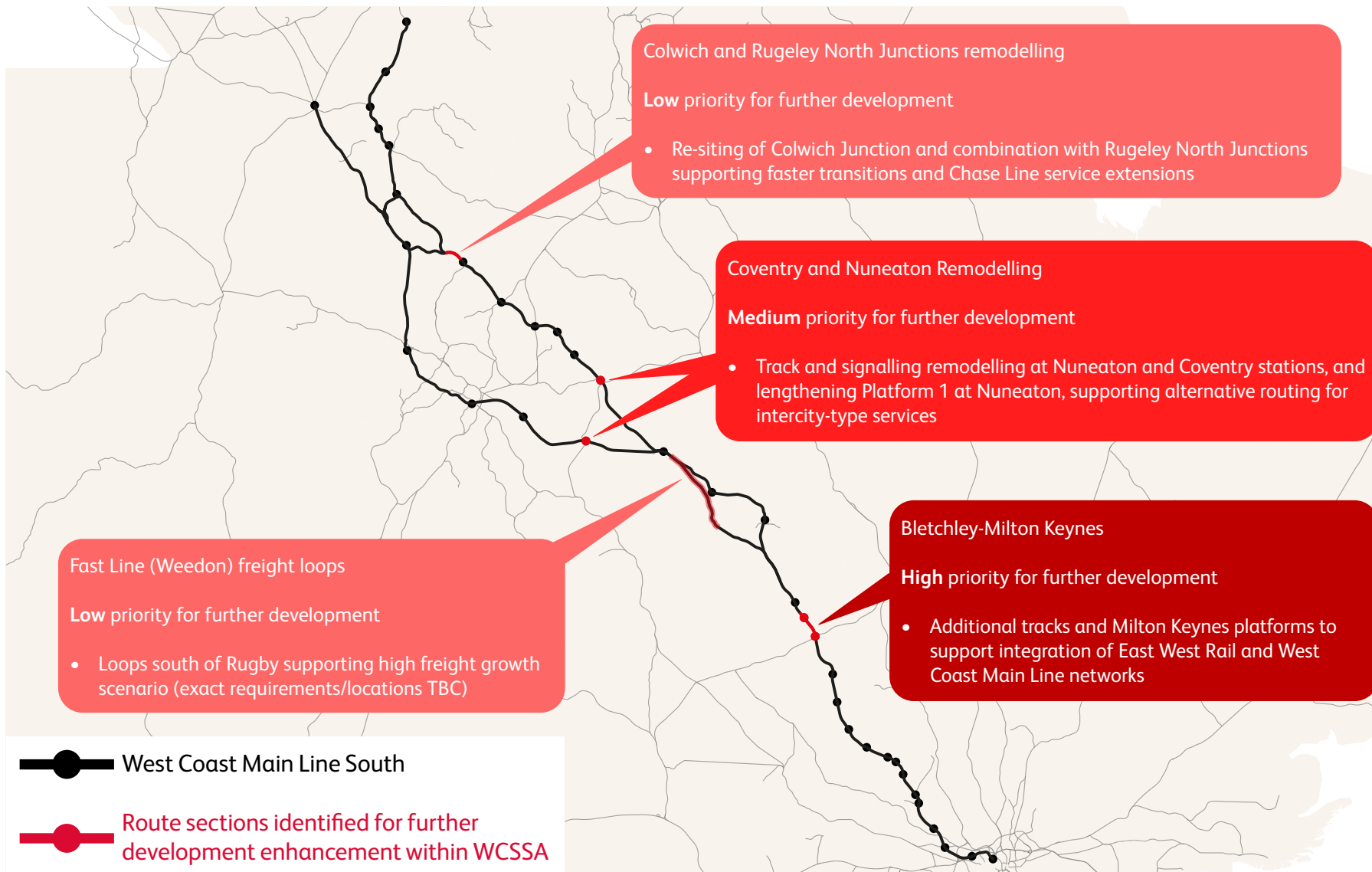

Recommendations and Further Work

This document also provides some further recommendations following on from the results of the scenario testing:

- Re-drawing of the West Coast Main Line South operator map should be explored further to realise operational efficiencies in the post-HS2 period, including separating service groups at Northampton and providing a single primary operator (excluding London Overground and Caledonian Sleeper services) at London Euston,
- Sufficient power supply arrangements must be provided in the long-term to ensure electric traction for all passenger services and, critically, for freight which will maximise the use of available track capacity as well as contributing wider decarbonisation benefits,
- Loading Gauge enhancements (either in full or incrementally toward W12) could be developed further to make sure that all types of freight traffic can operate on West Coast Main Line South, compounding the freight benefits associated with released capacity,

Network Rail will now continue to work with specifiers, funders and the wider industry to progress the recommendations related to utilisation of released capacity, infrastructure enhancement and those bullet pointed above.

This document concludes with some suggested pieces of further strategic analysis which will be required to further the overarching recommendations made here. This includes more focused pieces of strategic advice for the **Milton Keynes** and **Stoke-on-Trent** areas as prevailing points of long-term constraint, a wider **freight routing study**, further work on future **long-distance passenger markets** and demand, and a **West Northamptonshire area local stations needs assessment**. Network Rail will now work with industry partners to progress these items following the production of this West Coast South Strategic Advice report.

Document Purpose and Structure



Background

The south end of the West Coast Main Line (WCML) route, defined here as the route from Euston to Crewe and Macclesfield and including lines via Northampton and the West Midlands, has historically been one of the busiest mixed used rail routes in the UK. It provides a spine between London, the West Midlands and the Northwest, serving a variety of markets across inter-city, inter-regional, commuter and freight traffic.

While the COVID pandemic has severely impacted public transport, it is anticipated that demand for rail travel – both passenger and freight - will return substantially to a level and rate of growth comparable to the period immediately prior to COVID around the mid-2020s, though at present there is still no fully reliable forecast which captures to long-term effects of the pandemic on demand for rail travel.¹ However, the swift recovery to approximately 80-85 % of pre-COVID demand on West Coast South (as of December 2022), coupled with background growth over the long-term, means there is still an imperative to plan the long-term future network on the basis of increasing usership and improving both the passenger and freight offering.

It is in this context of largely recovered demand and a return to background growth that the transformative effect of HS2 will occur on the West Coast route. This will involve altering the composition of rail traffic operating on the conventional

infrastructure as long-distance Intercity West Coast (ICWC) services are transferred - or 'released' - to the high-speed network, making a significant quantum of additional conventional capacity available for other purposes. Network Rail, in collaboration with industry partners, has undertaken previous studies to identify the quantum of this released capacity on the West Coast South route, exploring options to use it for additional commuter, interregional and freight traffic, as well as providing a comparable level of intermediate connectivity between places that will not be directly connected by HS2. This work has provided a starting point to look in more detail into potential requirements and options to enhance the network in future.

This work draws on previous analysis to comprehensively consider the long-term future of the conventional West Coast South network with a wider scope, including and beyond the introduction of HS2 services. This entails identification and evaluation of realistic, credible options to maximise the utilisation of released capacity, address parts of the network where HS2 does not offer a direct benefit, and change the use of West Coast South route to accommodate growth and serve an expanded range of future users.

¹ For an outline assessment in which bulk demand is thought to recover to a broadly pre-COVID level by the mid-2020s, see: DfT/Imperial College London (procured by Rail Delivery Group); future rail travel demand scenarios (2021).

Purpose

Network Rail's Northwest and Central Region Strategic Planning team has identified a problem which this document seeks to address, distilled into the following overarching strategic question:

What opportunities are there to enhance the West Coast South network between Euston and Crewe/Macclesfield following HS2 introduction, and what is required to realise those opportunities?

A single, definitive answer cannot be provided in response to this question given the time-horizon over which this problem is cast, the range of objectives which could inform future use of the network, and uncertainty about intervening changes in the wider economy, demand for rail travel and policy response from government. However, answering the overarching strategic question through identification of future scenarios, likely constraints, and potential solutions is imperative now for the following reasons:

- a. To give sufficient clarity on what is required to achieve government and industry transport policy priorities in future, and assess the trade-offs to guide decision-making,
- b. To give sufficient time to allow for planning from 'first principles', remaining responsive to shifts in the HS2 specification or the wider transport context,
- c. To identify a future direction of travel around which assurance of strategic fit for proposed changes to West Coast South train service and/or infrastructure can be aligned,
- d. To give sufficient time to fund and develop options to address constraints or unlock wider benefits resulting from strategic study,
- e. To undertake comprehensive analysis and present strategic options for funders and guide efficient use of resource, operational and capital expenditure for partner organisations.

This West Coast South Strategic Advice (WCSSA) report is produced in fulfilment of Network Rail's licence obligation to plan the long-term future of the railway infrastructure. It is intended to be an early maturity assessment which informs further development work through a series of summary recommendations.

The recommendations made in this advice are based on a specific set of assumptions on scope and needs, as well as a staged method of assessment in which future train service scenarios have been developed (in coordination with the rail industry) and tested by Network Rail's Advanced Timetabling and Economic Analysis functions. This scenario-based approach provides clarity on future trade-offs and constraints, as well as an evidence base for the periodisation of potential long-term enhancements. How this method has been used, and the results of the assessment which determine the recommendations made, is explained in more detail in the following sections.

The WCSSA workstream has been undertaken primarily as a long-term, route study-type assignment with an accordingly wide scope. The resulting recommendations will generate a need for further strategic advice which narrows focus to specific geographic areas or points of constraint on the network. These will be planned and consulted with the wider industry transparently, following on from the overarching findings articulated in this report.

The analysis takes as a starting point the transformative effect of HS2 in releasing conventional network capacity. It evaluates the range of opportunities that are generated on the conventional and as such, the findings of this report are largely dependent on construction of the planned high speed infrastructure and operation of associated high-speed services as currently remitted and committed to in the government's Integrated Rail Plan for the Midlands and the North (IRP).² The assumptions and approach taken to HS2 - and what is meant specifically by 'released capacity' - are detailed in the following sections. Crucially, this work has not evaluated any specific changes to the conventional network derived from the staged introduction of HS2 services before the opening of the Euston-Crewe route. This work provides an assessment of the post-HS2 'end-state'; any incremental changes ahead of this point should align with the long-term direction of travel as described in this strategic advice.

This work has been produced with input and feedback from industry partners including the Department for Transport (DfT), Sub-National Transport Bodies (SNTBs), and Train and Freight Operating Companies (TOCs/FOCs). A description of the governance process and a full list of involved organisations can be found in Appendix A.

Document Structure

The following sections of this document step through an explanation of the methods adopted, the outputs of the analysis and consequent recommendations:

Section 2	Section 2 sets out the objectives which have been used to guide the WCSSA scenario testing. This section links to wider government policy and objectives for rail, presents the methods by which train service recommendations have been assessed against the objectives, and explains how the different scenarios tested in the analysis have been determined.
Section 3	Section 3 sets out the scope and assumptions which govern the construction and testing of train services scenarios, including the approach taken to available conventional network capacity following introduction of high-speed services. This section provides a statement of what must be delivered in the intervening period for all the findings of the WCSSA analysis to remain valid.
Section 4	Section 4 states a series of 'Planning Principles' which include the basic approach to freight and minimum passenger service requirements. These have been derived through consultation with industry partners and following an economic opportunity assessment undertaken by Network Rail specifically for this work. The Planning Principles inform the construction of all train service scenarios, giving a basic direction of travel for Network Rail's long-term planning post-HS2 and a core set of requirements for post-HS2 train service change.



Section 5	Section 5 presents the findings from each of the scenario tests undertaken as part of the WCSSA workstream. Each sub-section steps through the assessment for a given scenario, explaining the construction of the train service structure, the findings of the capacity analysis and the comparative economic assessment, as well as highlighting key constraints and what enhancements or trade-offs may be required in future to resolve them.
Section 6	Section 6 gives summary recommendations based on the analysis undertaken, advising how to maximise utilisation of released capacity as well as offering a prioritisation of infrastructure enhancement packages for the long-term. A wider set of recommendations related to rolling stock, operator mapping, stations, freight operations and gauging, power supply and weather resilience are also provided.
Section 7	Section 7 is a summary of outputs outlining the next steps which should be taken following on from the production of West Coast South Strategic Advice. Subjects for immediate further work and strategic analysis are provided. These will require ongoing input and engagement from industry partners that have been involved in the work so far.

For the sake of clarity, much of the base data generated through WCSSA has been included in appendices. Where this is material to specific assertions or findings the relevant appendix has been signposted in the narrative.

Objectives and Methodology



WCSSA Key Objectives

West Coast South Strategic Advice starts from the premise that utilisation of capacity on the rail network over the long-term should be guided by the government's transport policies and associated objectives for the rail industry. This includes the government's stated aim to use rail to expand public transport provision and support economic and housing growth as outlined in the Williams-Shapps Plan for Rail³, the need to utilise capacity in a manner which improves local and regional connectivity whilst maximising economic value as stated in both the Integrated Rail Plan⁴ and Union Connectivity Review⁵, and the ambition to encourage modal shift and decarbonise the network in pursuit of the government's Net-Zero by 2050 emissions target and the linked Transport Decarbonisation Plan⁶.

All the work undertaken as part of the WCSSA study has been determined by a set of five key objectives, shown in Table 1. These are informed by government policy and aligned to the

government's objectives for rail which are; meeting customers needs, delivering financial stability, contributing to long-term economic growth, levelling up and connectivity, and delivering environmental sustainability.⁷

The key objectives set as part of this workstream act as a way of evaluating future changes to the rail system in the context of a piece of strategic advice, and tracing those changes back to stated government policy. Evaluating train service outputs against multiple objectives also means it is possible to compare the extent to which network capability could be focused on delivering one objective, or set of objectives, over another. This is especially pertinent on West Coast South where the conventional network capacity released by HS2 presents the opportunity to construct the train service in a fundamentally different way, delivering a range of potential future outcomes in line with the strategic case for HS2 as set out by the Transport Secretary's 2013 statement of case.⁸

³ Department for Transport (2021) 'Great British Railways: The Williams-Shapps Plan for Rail' (available [online](https://assets.publishing.service.gov.uk/government/uploads/system/uploads/attachment_data/file/994603/gbr-williams-shapps-plan-for-rail.pdf), at: https://assets.publishing.service.gov.uk/government/uploads/system/uploads/attachment_data/file/994603/gbr-williams-shapps-plan-for-rail.pdf)

⁴ Department for Transport (2021) 'Integrated Rail Plan for the North and Midlands' (available [online](https://assets.publishing.service.gov.uk/government/uploads/system/uploads/attachment_data/file/1038561/integrated-rail-plan-for-the-north-and-midlands-web-version.pdf), at: https://assets.publishing.service.gov.uk/government/uploads/system/uploads/attachment_data/file/1038561/integrated-rail-plan-for-the-north-and-midlands-web-version.pdf)

⁵ Department for Transport (2021) 'Union Connectivity Review: Final Report' (available [online](https://assets.publishing.service.gov.uk/government/uploads/system/uploads/attachment_data/file/1036027/union-connectivity-review-final-report.pdf), at: https://assets.publishing.service.gov.uk/government/uploads/system/uploads/attachment_data/file/1036027/union-connectivity-review-final-report.pdf)

⁶ Department for Transport (2021) 'Decarbonising Transport: A Better, Greener Britain' (available [online](https://assets.publishing.service.gov.uk/government/uploads/system/uploads/attachment_data/file/1009448/decarbonising-transport-a-better-greener-britain.pdf), at: https://assets.publishing.service.gov.uk/government/uploads/system/uploads/attachment_data/file/1009448/decarbonising-transport-a-better-greener-britain.pdf)

⁷ Great British Railways Transition Team (2022) 'Whole Industry Strategic Plan: Call for Evidence' (available [online](https://gbrtt.co.uk/wp-content/uploads/2022/06/WISP-Call-for-Evidence-analysis-report-JUNE-2022-Final.pdf), at: <https://gbrtt.co.uk/wp-content/uploads/2022/06/WISP-Call-for-Evidence-analysis-report-JUNE-2022-Final.pdf>)

⁸ Department for Transport (2013) 'The Strategic Case for HS2' (available [online](https://assets.publishing.service.gov.uk/government/uploads/system/uploads/attachment_data/file/260525/strategic-case.pdf), at: https://assets.publishing.service.gov.uk/government/uploads/system/uploads/attachment_data/file/260525/strategic-case.pdf)

Table 1: West Coast South Strategic Advice guiding study objectives for rail.





WCSSA Objective	Targeted Outcome	Opportunity Analysis Assessment	Opportunity Analysis Output
 <p>Maximise Revenue</p>	Improved journey times, connectivity, and capacity which grow existing major revenue flows.	Modelled flow-by-flow data showing pre-COVID yearly revenue yield with HS2 abstraction rates assumed.	Prioritised list of existing flows based on total revenue and revenue per mile between all WCSSA locations (and major externals), split across four market types (short, medium, long distance and London commuter).
 <p>Supporting Development</p>	Improved connectivity for passenger service from locations which are identified as more deprived relative to other locations within the study scope.	Generalised Journey Time and Speed assessment of existing flows to all West Coast South locations <i>from</i> tier 1 and 2 Government 'levelling up' locations.	Prioritised assessment of flows from tier 1 and 2 locations to other WCSSA locations and externals where rail provision currently does not meet Generalised Journey Speeds comparable with other flows.
 <p>Encourage Modal Shift</p>	Improvement in journey times, frequency, connectivity, and capacity between locations where there is a clear opportunity to abstract trips from private car to rail.	Assessment of road/rail mode share split using the planet model, and assessment of pre-COVID Generalised Journey Times and Speeds for all flows.	Prioritised list of flows where rail mode share, generalised journey speed, and volume of road traffic present greatest opportunity to induce modal shift for passenger service.

Table 1: West Coast South Strategic Advice guiding study objectives for rail.

WCSSA Objective	Targeted Outcome	Opportunity Analysis Assessment	Opportunity Analysis Output
 <p>Stimulate New Markets</p>	<p>Stimulation of growth in new passenger markets which are currently underserved by rail; connecting communities, growing future revenue and unlocking suppressed demand.</p>	<p>Assessment of the economic benefit of flows with no or poor direct connections among WCSSA locations and externals, applying an indicative 10% reduction in GJT using PDFH elasticity-based demand values.</p>	<p>Prioritised list of flows showing indicative value of Level 1 Transport Benefits accrued from benchmark improvement in GJT, giving a comparative assessment of the potential to stimulate new demand through improved service.</p>
 <p>Support Freight Growth</p>	<p>Support for growth in rail freight, meeting forecasts and encouraging modal shift from road to rail through provision of expanded capacity and routing options for freight.</p>	<p>Conversion of high-growth forecasts to line-of-route required tonnages and benchmark Marginal External Cost (MEC) assessment quantifying the impact in freight modal shift compared to December 2022 levels.</p>	<p>Construction of a 'high growth' freight ITSS for West Coast South route, based on priority future flows, factored into all scenarios and prioritised in one.</p>

A specific method of assessment has been developed for each of the WCSSA study objectives. These assessment methods are intended to give a high-level but quantifiable result for any train service changes tested in the WCSSA workstream, tracking the extent to which different train service structures can be said to deliver on a specific objective or set of objectives. The assessment criteria control for abstraction to HS2 services reflecting the scope and timeframe of this study.

Table 1 also shows the baselining output for each of the objectives. This refers to the results of an economic opportunity analysis - undertaken as a first step in the strategic advice process - which attributed a value for station-to-station flows based on a benchmark test of each assessment method. This baselining activity has been used to guide the construction of train service scenarios throughout the workstream as well as informing the basic Planning Principles on which all WCSSA recommendations are based.

A specific objective and assessment method has been included for freight. This is so that the potential freight benefits derived from train service and infrastructure options tested as part of this work can be tracked for comparative purposes. While it is recognised that rail freight makes a strong contribution to the other objectives identified⁹, this study does not make a recommendation on the level of freight or passenger service which must operate instead provides an assessment of network

capability to support different train services. The approach taken to rail freight, and how it has been factored into the train service scenario testing, is described in more detail in Planning Principle A (in section 4 of this report).

Multiple passenger-specific objectives have been adopted on the grounds that released capacity and the route-wide scope of this work mean the greatest potential for variation is with the passenger service structure. The assessment methods adopted are necessarily high level and used to compare different train structures with each other, giving a view on the potential maximisation of released capacity and the priority network constraints to inform future enhancement.

Throughout the report, where a scenario train service has been tested, a percentage figure is provided against each objective. This represents the relative change from a released capacity economic baseline which includes a nominal level of conventional network service and a December 2022 level of freight, and includes HS2 services operating on the high-speed infrastructure. The methods of measurement used are based on different absolute figures for each objective, and so the results for each objective across a single scenario are not directly comparable. For example, a small percentage change in the overall revenue test cannot be directly evaluated against a large percentage change in the overall freight test within a given scenario. The results have been organised to show where

⁹ Deloitte / Rail Delivery Group (2021) 'Assessing the Value of Rail Freight' (available [online](https://www.raildeliverygroup.com/media-centre-docman/12807-2021-04-role-and-value-of-rail-freight/file.html), at: <https://www.raildeliverygroup.com/media-centre-docman/12807-2021-04-role-and-value-of-rail-freight/file.html>)

a scenario train plan generated the greatest change in each objective test compared to the other scenario train services for that objective. The colour coding and presentation of results throughout the document is intended to reflect this comparative assessment, and should not be used as a basis to determine a 'best' or 'optimum' ITSS.

Further development work will be required to generate absolute values and begin the construction of a Benefit/Cost Ratio should any of the train service or infrastructure enhancement recommendations outlined in this report progress.

This report provides a strategic-level overview of the long-term opportunities and priorities for West Coast South Route. Network Rail will continue to work with industry partners to develop the train service and infrastructure recommendations further.

Scenario Based Testing

The WCSSA workstream does not define an end-state train service specification for the post-HS2 period. Recognising that circumstances, policy preferences or the wider economic context could significantly alter the requirements placed on the rail industry, the study has adopted a scenario-based approach. This involves construction of a range of possible scenario Indicative Train Service Specifications (ITSSs) which are then tested to illuminate the trade-offs in using future rail capacity for different ends.

Five scenario ITSSs (shown in table 2) have been constructed, each with a specific focus, targeting an objective or set of objectives. This scenario-based approach means the testing can show what is possible or required to achieve a train service structure that is geared toward, for example, maximisation of freight benefits or stimulating new passenger rail markets. The results of the analysis demonstrate what is achievable in supporting the scenario focus within existing infrastructure constraints, using the capacity released by HS2, and what enhancements might be required to support the required outcome more fully.

The scenario ITSSs that have been tested as part of WCSSA have been constructed from first principles. They are not incremented forward from a base timetable but have instead been built to deliver a set of connectivity or quantum requirements, for example, a minimum level of passenger service (trains per hour) between an origin and a destination. These requirements

have been drawn, in the first instance, from the outputs of the economic opportunity analysis providing some minimum service requirements which are common to all scenario ITSSs, as well as additional scenario-specific requirements which are derived from that scenario's guiding objective(s) and associated priority flows. The minimum requirements are explained in the Planning Principles (section 5) of this report, while scenario specific requirements are explained throughout the scenario testing (section 6).

The opportunity analysis outputs have been used in this process as a guide. Both the Planning Principles and scenario-specific requirements have been determined in conjunction with transport planning partners in the industry. This ensures alignment with the long-term direction of travel as evidenced and articulated in partner organisations published strategies, including specific future service aspirations as outlined in:

- **Midlands Connect's Strategic Transport Plan**¹⁰, Freight Routemap for the Midlands¹¹, and Shrewsbury Corridor study¹²,
- **England's Economic Heartland's Transport Strategy**¹³, Passenger Rail Study¹⁴, and Oxford-Milton Keynes Connectivity Study¹⁵,
- **West Midlands Rail Executive's Rail Investment Strategy**.¹⁶

¹⁰ Midlands Connect (2022) 'Fairer, greener, stronger: our Strategic Transport Plan for the Midlands' (available [online](https://www.midlandsconnect.uk/media/1864/summary-document-midlands-connect.pdf), at: <https://www.midlandsconnect.uk/media/1864/summary-document-midlands-connect.pdf>)

¹¹ Midlands Connect (2022) 'Our Freight Routemap for the Midlands' (available [online](https://www.midlandsconnect.uk/media/1891/mc-freight-routemap-summary.pdf), at: <https://www.midlandsconnect.uk/media/1891/mc-freight-routemap-summary.pdf>)

¹² Midlands Connect (2021) 'Rails to Recovery: Building Back Stronger' (available [online](https://www.midlandsconnect.uk/media/1778/mc-rails-to-recovery-digital.pdf), at: <https://www.midlandsconnect.uk/media/1778/mc-rails-to-recovery-digital.pdf>)

¹³ England's Economic Heartland (2021) 'Connecting People, Transforming Journeys: Regional Transport Strategy' (available [online](https://eeh-prod-media.s3.amazonaws.com/documents/Connecting_People_Transforming_Journeys_av.pdf), at: https://eeh-prod-media.s3.amazonaws.com/documents/Connecting_People_Transforming_Journeys_av.pdf)

¹⁴ England's Economic Heartland / Network Rail (2021) 'Passenger Rail Study Phase Two' (available [online](https://eeh-prod-media.s3.amazonaws.com/documents/EEH_Passenger_Rail_Study_Phase_2_Report.pdf), at: https://eeh-prod-media.s3.amazonaws.com/documents/EEH_Passenger_Rail_Study_Phase_2_Report.pdf)

¹⁵ England's Economic Heartland (2022) 'Oxford-Milton Keynes Connectivity Study' (available [online](https://eeh-prod-media.s3.amazonaws.com/documents/Oxford-Milton_Keynes_connectivity_study.pdf), at: https://eeh-prod-media.s3.amazonaws.com/documents/Oxford-Milton_Keynes_connectivity_study.pdf)

¹⁶ West Midlands Rail Executive (2022) 'Rail Investment Strategy Consultation Draft' (available [online](https://wmre.org.uk/media/pbuhz13p/west-midlands-rail-investment-strategy-consultation-draft.pdf), at: <https://wmre.org.uk/media/pbuhz13p/west-midlands-rail-investment-strategy-consultation-draft.pdf>)

What is an Indicative Train Service Specification?

An Indicative Train Service Specification (ITSS) defines a quantum of train services between a range of origins and destinations. It typically includes routing, calling patterns between origin and destination, assumed rolling stock types and intervals between service groups.

The ITSS can be 'tested' through rail capacity analysis to create a Concept Train Plan (CTP) which includes timings for services within the assumed infrastructure, effectively forming a prototype timetable. In the WCSSA workstream this analysis has been undertaken by Network Rail's Advanced Timetabling Team (ATT).

The train services included in the CTP can then be modelled to show their relative economic value based on journey times, frequency, and potential for interchange. The capacity analysis work also shows where constraints emerge on the infrastructure and can be used to identify possible enhancements.

The ITSSs and CTPs produced through the testing undertaken in this work are explained in section 5. This work, along with the comparative assessment of the CTPs, has informed the recommendations provided in section 6.



Table 2: West Coast South Strategic Advice train service scenarios.

Scenario ITSS	Guiding Objective(s)	Rationale
1 Freight Focus	Support Freight Growth	The Freight scenario incorporates an uplifted quantum of freight, in line with a high growth forecast, and prioritises freight services in within the capacity analysis. This demonstrates what can be accommodated should freight uplift be the priority for the conventional network post-HS2, and what specific interventions may be required on West Coast South Route should very significant growth in rail freight be sustained over the long-term.
2 Intermediate Markets	Maximise Revenue Support Development	The Intermediate Markets scenario targets improved connectivity and passenger service between urban locations on West Coast South route, and key external locations, which will not be served directly by HS2. The focus is on supporting established, high revenue/demand flows and markets whilst controlling for abstraction to the high-speed network.
3 East West Connectivity	Stimulate New Markets Encourage Modal Shift Support Development	The East West Connectivity scenario targets distribution of connectivity benefits to a wide range of locations as well as integrating the West Coast South and planned East West Rail routes with cross-boundary passenger and freight services. Outputs demonstrate the impact of focusing on expanding the rail market and directly connecting a wider range of communities by rail instead of focusing on the most significant pre-existing flows.

Table 2: West Coast South Strategic Advice train service scenarios.

Scenario ITSS	Guiding Objective(s)	Rationale
4 New Connections	<p>Stimulate New Markets</p> <p>Encourage Modal Shift</p> <p>Support Development</p>	<p>The New Connections scenario targets provision of new direct connections by rail for communities which are not currently connected and serving a range of potential new stations. Outputs demonstrate the impact on the whole train service – and potential infrastructure requirements - where additional calls must be incorporated at places which are not currently connected to the rail network in the December 2022 timetable structure.</p>
5 Commuter Peak	<p>Maximise Revenue (Commuter Flows)</p>	<p>The final Commuter scenario ITSS is based on a significant uplift in local and suburban traffic, primarily into London. This scenario de-prioritises freight in one direction and therefore acts as a post-HS2 ‘peak’ test for West Coast South route, identifying potential trade-offs and impacts especially at conventional network stations, including London Euston.</p>

Testing Process: Concept Train Plans

Once a scenario ITSS has been constructed around a primary focus and objective(s), it has then been handed to Network Rail's Advanced Timetable Team (ATT) team who build a compliant Concept train plan (CTP) assuming only the existing infrastructure. This demonstrates for each scenario what level of service can be accommodated utilising only the capacity released by HS2 as a baseline. This is referred to as the **released capacity concept train plan** for any given scenario.

The constraints associated with the existing infrastructure drive the need to make trade-offs. This has been undertaken based on the priority ascribed; for example, in a freight focus scenario, freight services have been prioritised in the released capacity CPT at the expense of passenger services where necessary. The collected results demonstrate the opportunity associated with using released capacity for different ends, but also where the existing infrastructure limits any further improvement or threatens performance.

In addition to a released capacity CTP, every scenario has generated a **'with infrastructure' concept train plan** which assumes the full range of interventions required to accommodate all, or the vast majority, of services specified in that scenario ITSS. Again, the prioritisation of services in the 'with infrastructure' CTPs has been determined based on the specific focus of that scenario.

A primary aim of West Coast South Strategic Advice is to

evaluate the next set of constraints on the conventional West Coast South route following HS2 introduction. This has been achieved by comparing the results of the scenario testing and tracking the incremental train service changes across all scenarios. Section 6 of this report summarises the outputs of all the testing and includes a cross-scenario assessment of the infrastructure options identified. This has informed a recommendation on infrastructure 'packages' which could be developed further.

The infrastructure design work that has been undertaken is at an early stage of maturity and should not be assumed to be a final product. Likewise, it has not been possible in a study of this scale and scope to identify every infrastructure change required to accommodate every service in every scenario. Instead, the results of the testing demonstrate the interventions that may be required in future to support the objectives and priority services in each scenario, and across all scenarios cumulatively. Further detailed analysis will be required to establish a more specific scope and train service changes on a case-by-case basis and maximise the capability of the identified enhancements through capacity analysis replanning. Further development work should be pursued in line with the recommendations outlined in section 6 of this report.

Capacity Planning

All of the Concept train plans presented in this work have been constructed from first principles, maximising the capability of the assumed infrastructure. However, this involves using techniques which are common to capacity planning and should be explained further before the results of the analysis are presented.

Flighting

Trains are planned on to the network in sequence over a given line of route. The minimum gap in time between one train and the next is known as the 'headway'; each line of route has a minimum headway value which must be factored into a train plan to be compliant. For example, on the West Coast Main Line fast lines between London Euston and Rugby it is three minutes meaning a passenger service departing Euston via the fast lines must be at least three minutes behind the preceding departure. While compliant, planning trains consecutively on minimum headways presents a risk to performance by leaving no time to recover delays and so it is prudent to leave a longer gap where possible.

Passenger services and freight utilise the network in different ways. Some intercity-type passenger services may be planned with very few calls over a long distance, for example, an intercity-type train between London Euston and Birmingham New Street may call at Watford, Milton Keynes, Coventry and Birmingham International. A local-type service on the same line of route may call additionally at Hemel Hempstead and Leighton Buzzard.

If the intercity train follows the local train it will be forced to slow down as the local train calls at Hemel Hempstead. This generates a pressure to use network capacity efficiently by ordering trains into a 'flight' where the fastest passenger services precede more frequently stopping services and slower freight; this is a common industry technique used to ensure efficient use of network capacity. The most efficient way to plan services from a capacity utilisation perspective would be to plan all services in a single flight, with the fastest services first, as shown in Figure 1. In reality this must be balanced against the need to call trains of the same time at even intervals across the hour, generally resulting in a partially flighted plan like that shown in Figure 2. This most effectively balances network capacity with the wider need to provide sufficiently frequent connections for stations along the route.

In general, the concept train plans produced as part of West Coast South strategic advice have sought to balance effective use of capacity through flighting across the length of route, with the need to connect a range of different locations with sufficiently frequent service. The trade-off between heavily flighting the train plan and wider connectivity is determined by the requirements in any given scenario within this work. This has been captured throughout the testing, exploring the extent to which removal of the longest distance limited stop passenger services to the HS2 network creates flexibility for closer flighting or redistributing station calls.

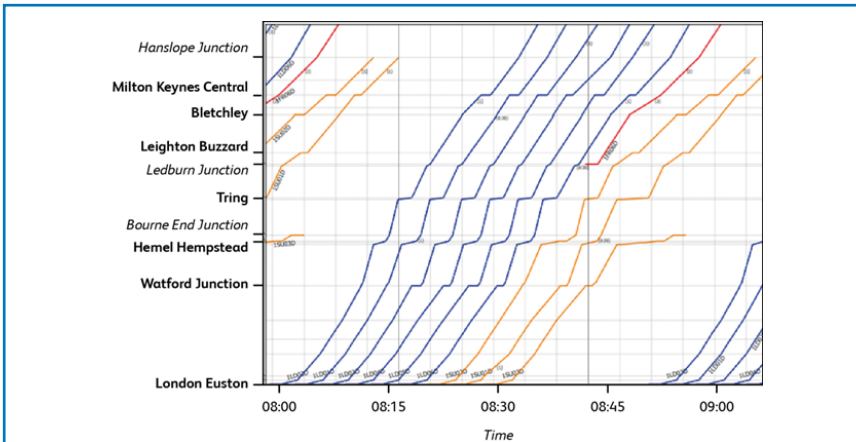

Figure 1: An 'optimally' flighted train plan, where utilisation of capacity is maximised. This limits the ability to provide suitable intervals and frequency of calls in reality.

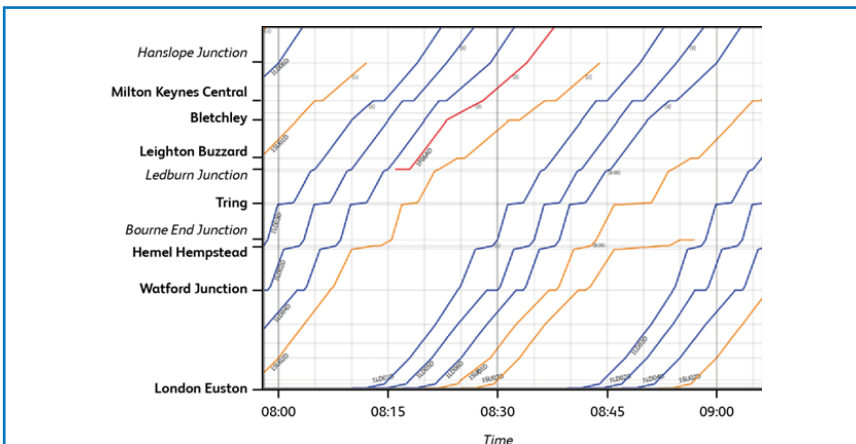

Figure 2: A typically flighted train plan, balancing efficient use of track capacity with even interval, frequent services.

Crossing and Conflicting Moves

Balancing capacity with connectivity also requires planning train services to cross from one line to another at junctions. This is especially important on West Coast South where the four-track alignment often results in services planned on the fast lines for a portion of their journey, then crossing to the slow lines to accommodate required stations calls, enabling faster trains behind to overtake.

Where a train must move from one line to another at a junction sufficient time must be planned to negotiate the move; this is known as the 'junction margin'. Where a train is planned to cross over a line where trains run in the opposite direction – as train B has in Figure 3 – the junction margin will specify the minimum time that must be allowed for in the timetable for the 'conflicting' move.

These conflicting movements can consume capacity by limiting the extent to which trains can be flighted or closely planned to each other at flat junctions. However, the need to serve a range of places and markets with both passenger and freight services drives a need to plan for conflicting moves, utilising a range of routes as well as making best use of constrained capacity through movements between slow and fast lines.

In Figure 3, train C is shown serving local stations to Tring, train B is shown running fast line and crossing to the slow lines at Ledburn Junction to call at Leighton Buzzard, and train A is shown running fast line to London. While the most efficient use

of capacity would be to segregate fast and slow line services to eliminate crossing moves entirely, in this instance, the most effective balance between capacity and connectivity is to plan a semi-fast service (train B) beyond a terminating service at Tring, and move to the slow lines. While these crossing moves utilise capacity, they are required to maximise the capability of the network to support improvements in journey times and so the type of movement shown in Figure 3 is typical of that planned throughout the testing undertaken for the WCSSA work.

All Concept train plans produced as part of this work have been created in accordance with the 2022 Timetable Planning Rules (TPRs) which define minimum headways, junction margins and allowances on the existing infrastructure. It is especially important that the infrastructure can support this type of movement on West Coast South in future as maximisation of the capacity released by HS2 will entail an increased requirement to transit services between the fast and slow lines, as explained throughout the analysis present in subsequent sections.

More detail on the assumed baseline infrastructure and key junctions is provided in section 4.2. Where an enhancement to the infrastructure has been tested in the ‘with infrastructure’ concept train plans a reasonable assumption on junction margins has been made by the Advanced Timetabling team.

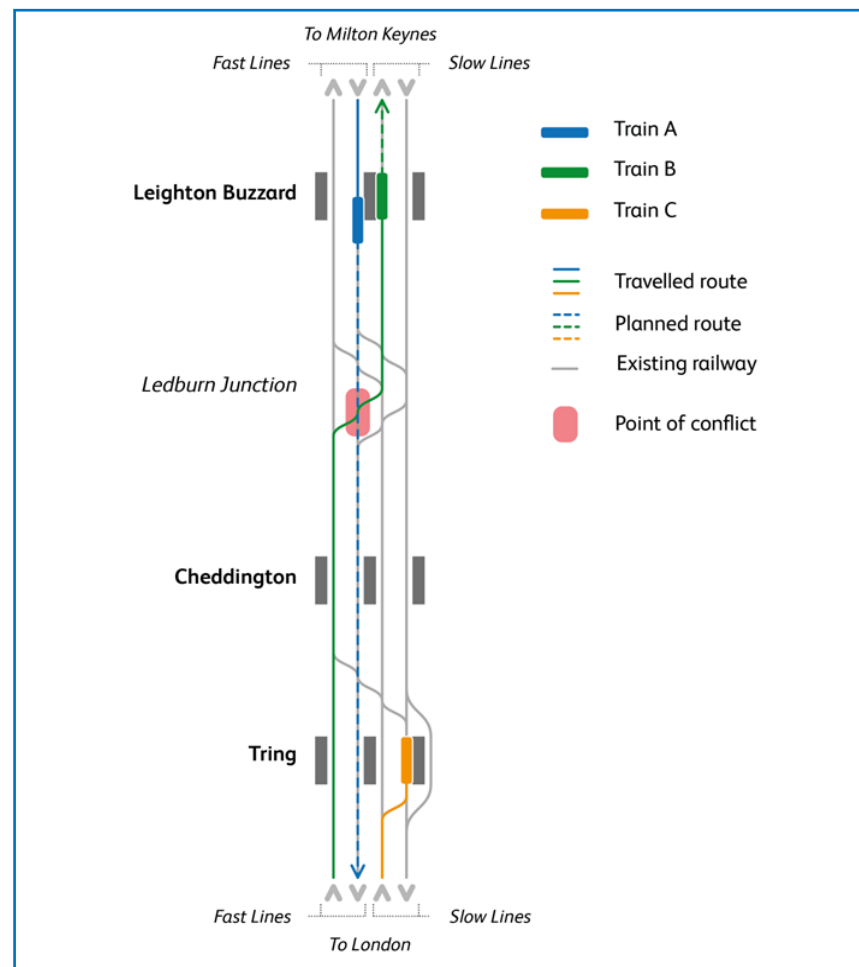

Figure 3: An example of a crossing move on West Coast South. Train B moves from fast to slow lines in the northbound direction, ahead of the Train moving south bound on the fast lines.

Concept train plan Economic Assessment

The objectives and the associated economic assessment methods have been used to evaluate all concept train plans, both released capacity and 'with infrastructure'. This assessment is comparative and is used only to judge the extent to which a specific train service structure achieves an improvement on the required objectives comparative to the others. To do this the economic modelling undertaken in the multi-criteria assessment has used a benchmark post-HS2 train service which reflects the scope of the work. This post-HS2 economic baseline:

- Accounts for the operation of HS2 services (which abstract demand from the conventional network for connected origins and destinations),
- Accounts for a nominal level of demand generated by the completion of the East West Rail programme between Oxford, Aylesbury and Cambridge,
- Assumes a level of conventional network service on West Coast Mainline commensurate with that informing the HS2 business case.

The assessment of each concept train plan is not designed to quantify all the wider economic benefits associated with operating the train services in any given train plan, nor does it attempt to quantify any absolute financial or revenue gains for planned services. Instead, the multi criteria assessment results provide a way of distinguishing the relative performance of

each concept train plan against the study objectives, and the capability of the infrastructure to accommodate them based on the improvements made to freight quantum and passenger service Generalised Journey Times (GJTs).

More detailed economic assessment will be required to determine the exact value of identified train services following the production of this strategic advice. This should involve replanning assumed train services to optimise use the interventions identified and modelling the wider economic and social benefits of the specific service changes they unlocked. This report provides – through its recommendations – a range of options which should be considered priorities for this further development.

What is Generalised Journey Time (GJT)?

GJT is often used in transport planning as it takes multiple effects and amalgamates them into one metric. It is calculated using a combination of average train frequency, in-vehicle time and interchange time between destinations. It also adds a penalty for having to change trains, not just the time it takes to physically take to change services.

$$\text{Generalised Journey Time (GJT)} = T + S + I$$

T = the total station-to-station journey time (including interchange time)

S = the service interval

I = the sum of the interchange penalties for any interchanges required

The use of GJT as a measure is important because it factors in relative disbenefit of an infrequent passenger service, even where a train service has a short headline journey time.

This is an important factor when assessing the use of released capacity, where there is significant potential to increase service frequency for a range of passenger flows.

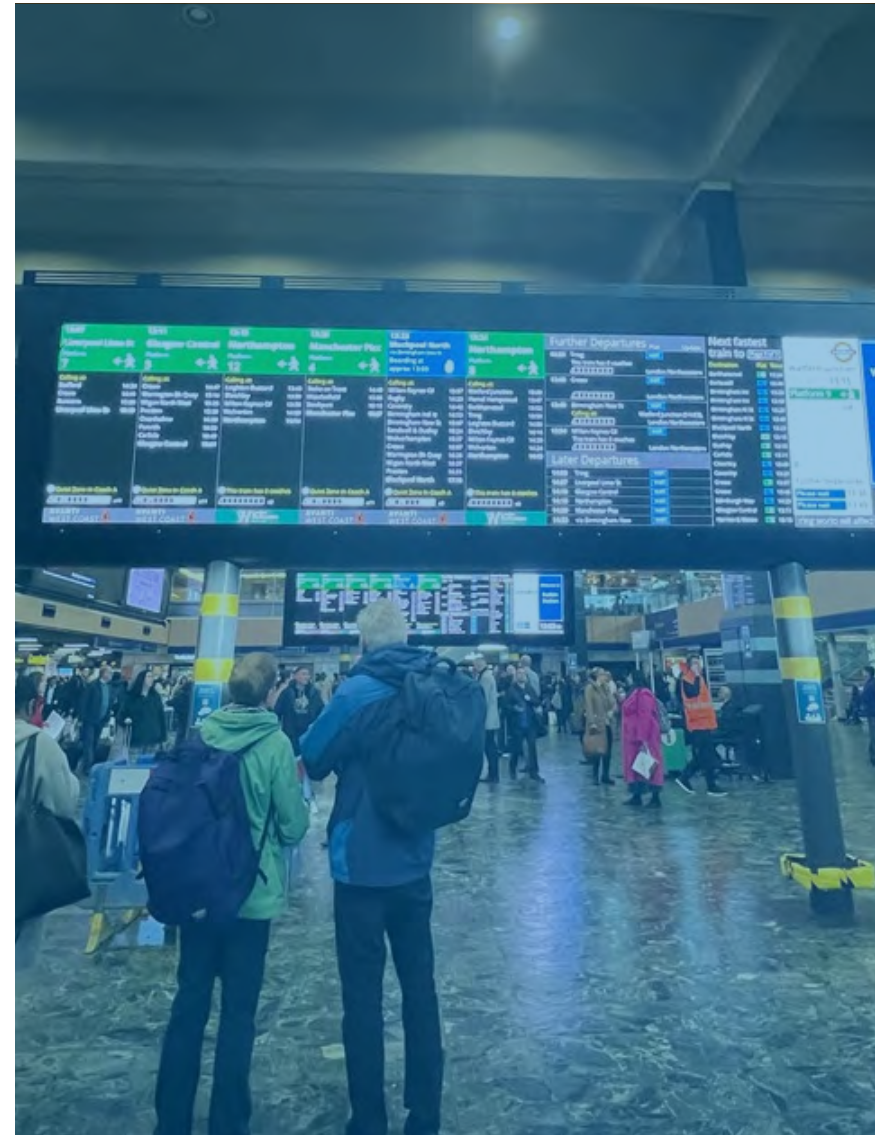

Performance in Concept train plans

The purpose of the WCSSA study is not to select an ITSS or inform a specific timetable change. The train plans that have been constructed and assessed in this work give a high degree of confidence about the capability of the conventional West Coast South network, post-HS2, and are used to inform where the 'ceiling' is in terms of available capacity. All the concept train plans generated as part of this work are compliant with Network Rail's Timetable Planning Rules (TPRs) meaning that they could be accommodated on the existing infrastructure.

Capacity utilisation (a basic measure of the number of train services planned over given route section over a given timeframe) has been taken into account in the concept train plan work. If capacity utilisation is high, over 75%, there is limited flexibility in the train plan to recover from delay as there is not enough space between trains to act as a buffer. This risks propagation of delay to other parts of the network and can force to cancellation of services.

Where a high capacity utilisation rate has been observed, or where Network Rail's Advanced Timetabling Team have identified a risk within a given concept train plan, the likely impact on performance has been captured in the narrative. The potential for identified infrastructure options to alleviate capacity utilisation and provide a beneficial impact on performance has also been considered and included in the priority assessment and recommendations in section 6.

However, further refinement and modelling would be required to fully assure the performance of any of the train plans generated as part of this work, identifying the extent to which a given train plan is susceptible to generating delays and how robustly it could recover should delays be realised. Given the purpose of the study and the stage of maturity of the advice, performance modelling has not been included in scope. Any timetable change undertaken on West Coast South must ensure resilient and robust operations with performance modelling undertaken. Likewise, should any of the recommended infrastructure enhancements identified in this work be developed further, it is critical that the train service outputs can be accommodated *reliably* on the wider network, requiring performance modelling as part of the development process.

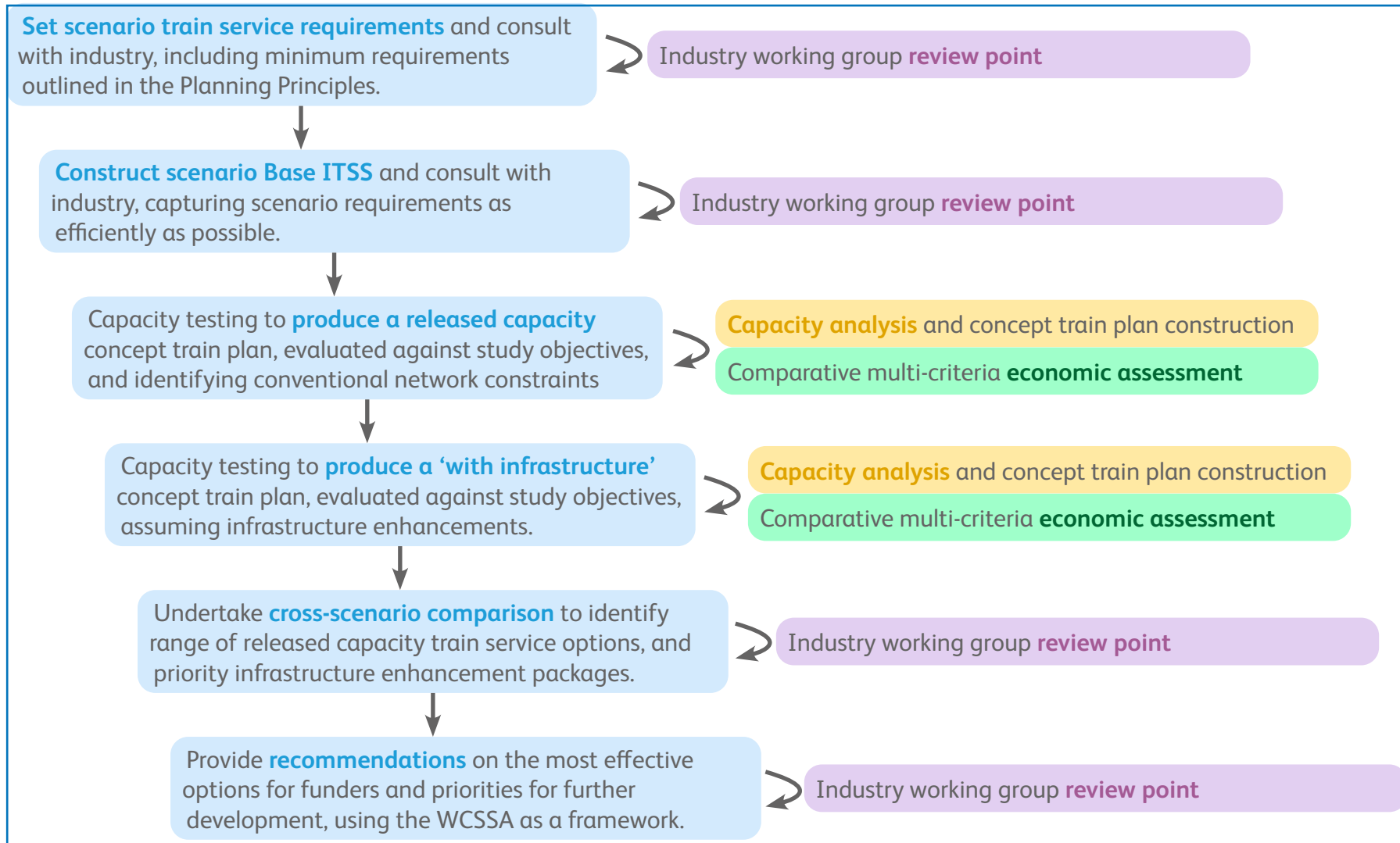

Figure 4: WCSSA Scenario testing process.

Scope and Assumptions



The testing process for West Coast South Strategic Advice has been undertaken within a defined scope and aligned to a basic set of assumptions. Any significant changes which affect the following assumptions may require the results of the analysis to be revisited, or further work commissioned.

Geographic Scope

The geographic scope for WCSSA covers the trunk main line route from Euston conventional station to Crewe and Trent Valley lines, as well as the Colwich to Manchester lines as far as Macclesfield.

The study also includes the Coventry and Wolverhampton corridors for the purposes of capacity analysis, aligning Concept train plans to current assumptions on the strategic direction of travel for the West Midlands. However, major infrastructure change on the route between Coventry and Wolverhampton via Birmingham will remain out of scope and has been assessed as part of Network Rail's West Midlands Strategic Advice (2022).¹⁷

Enhancement options for the St Albans Abbey line have not been assessed, noting that platform lengths on the branch will not permit an effective use of capacity for trains planned on to the main line to London Euston. This work assumes onward travel will be provided at Watford Junction, utilising the improved options for interchange made possible by the capacity

released by HS2 in future. Likewise, WCSSA has not determined enhancements for the Marston Vale line which will be delivered by the East West Rail programme.

The outputs from this study are aligned with those in the West Midlands Strategic Advice, ensuring validity of the assumed service levels through the Coventry and Wolverhampton corridors in all scenarios. Requirements in the Coventry area have been covered in this report however, given some scenarios include intercity-type services operating between Coventry and Nuneaton (via the West Coast Main Line) which warrant specific infrastructure assessment.

¹⁷ Network Rail (2022) 'West Midlands Strategic Advice' (available [online](https://sacuksprodnrdigital0001.blob.core.windows.net/regional-long-term-planning/North,%20West%20and%20Central/West%20Midlands%20Strategic%20Advice%202022.pdf), at: <https://sacuksprodnrdigital0001.blob.core.windows.net/regional-long-term-planning/North,%20West%20and%20Central/West%20Midlands%20Strategic%20Advice%202022.pdf>)

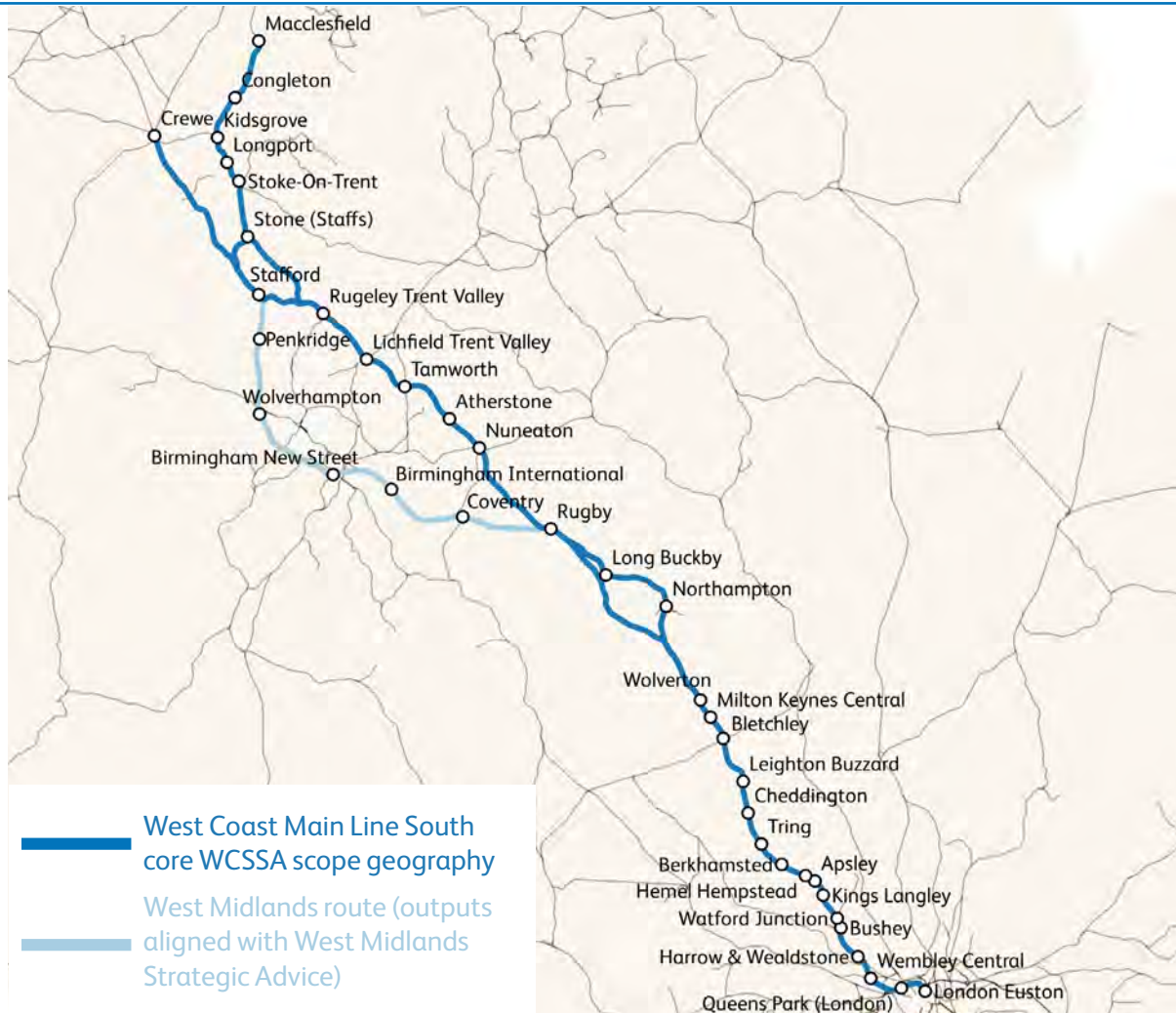

Figure 5: WCSSA scope geography (excludes Crewe station and local services in the West Midlands via Coventry and Wolverhampton corridors).

Conventional Network Infrastructure

Infrastructure is in scope for this work. Where a major change has been tested or identified for further development it has been captured fully in the results of the analysis.

As a baseline position the WCSSA testing has assumed today's (December 2022) existing conventional network infrastructure per Network Rail's Sectional Appendix, and the associated Timetable Planning Rules (TPRs).

Noting that there are ongoing workstreams to alter the conventional West Coast South infrastructure, some more detail is provided below on assumptions governing track layout and junctions, Euston station layout, prevailing speed profile, and electrification.

Track and Junctions

All switches, crossings and turnouts assumed as a base for this work are per the Sectional Appendix in December 2022. This includes layouts and speeds which are used as a basis to calculate the TPRs.

The testing has assumed a reinstated Watford North Junction as well as the addition of a fast-to-fast line crossover north of Watford Junction. Both schemes are funded and will have been delivered ahead of HS2 services and so the WCSSA testing has reserved the right to make use of the additional planning flexibility.

In testing the capability of the network as it is described in the Sectional Appendix, the testing has also assumed that assets that may not be regularly used today could be used more intensively in future provided this is compliant with the TPRs. No assumptions have been made about temporary or permanent abandonment of assets which remain operational per the Sectional Appendix as of December 2022.

West Coast South post-HS2 Speed Profile

The speed limits applied on West Coast South route – as with all routes - vary based on geography, track layout and geometry. However, these limits are applied within an overarching set of speed profiles which govern the maximum speeds which certain rolling stock types are permitted to reach across the route.

Enhanced Permissible Speed (EPS)	Max. 125mph, applied only to tilt-capable Class 390 and 221T rolling stock
Multiple Unit Differential	Max. 125mph applied to certain non-tilt multiple unit rolling stock types
Permissible Speed (PS)	Max. 110mph applied to any non-tilt/non-MU differential passenger rolling stock
Class 4 Freight	Max. 75mph applied to Class 4 freight, e.g. intermodal
Class 6 Freight	Max. 60mph applied to Class 6 freight, e.g. aggregates

Assumed linespeed profiles are important in the context of this analysis as the differential in speeds between passenger services and, crucially, between passenger and freight, have a direct impact on available network capacity. More capacity is required over a given line of route for a slower train, which in turn drives a need to flight services to efficiently use the available capacity (as described in the previous section).

Including a greater quantum of slower freight or passenger services as a proportion of the total on the network could exacerbate the speed differential issue and reduce overall capacity. The most efficient way to plan the network from a capacity perspective would be to use a single linespeed profile for all services. This is not technically feasible given the heavier weight for freight trains which has a much greater physical impact on the infrastructure relative to passenger services when operating at higher speeds as well as the much greater power requirement when hauling heavier trailing loads.

The WCSSA workstream has been undertaken on the assumption that HS2 will deliver headline journey time improvements for the longest distance passenger flows. It is assumed that tilting trains will not be required on West Coast South post-HS2 and that the Enhanced Permissible Speed profile can be decommissioned accordingly on the grounds of:

- Reducing the speed differential between passenger services and providing for a more efficient use of capacity,
- Reducing the cost of maintaining tilt on existing trains, the infrastructure and eliminating the need to procure tilting trains in future,
- Remaining consistent with the wider industry view on the post-HS2 timetable and future rolling stock requirements.

All passenger rolling stock run times used in the WCSSA testing have assumed a Permissible Speed profile which is limited to 110mph, or where there is an existing Multiple Unit differential (between Rugby and Coventry). This provides a right-side failure in which any raise in Permissible Speed or expansion of the Multiple Unit differential to other parts of the route will not affect the fundamental findings of the concept train plan work in this report.

Further consideration of linespeed enhancement and removal of tilt/EPs – and the effect on long-term network capability and capacity - is given as part of the recommendations provided in section 6 of this report.

Electrification and Power Supply

As noted in the background and objectives summary earlier in this report, it is a key aim for the Government to decarbonise the railway in support of its objective to achieve net-zero carbon emissions by 2050. This means eliminating diesel traction from the rail network, per network rail's Traction Decarbonisation Network Strategy (TDNS).¹⁸

While the trunk West Coast South Route is already fully electrified, future capacity could be used for hourly passenger train services which would run on to currently unelectrified route sections, principally Crewe to Chester, Wolverhampton to Shrewsbury, Coventry to Nuneaton and the infrastructure planned to be delivered by the East West Rail programme Oxford to Cambridge.

This report does not make any specific recommendations on the staging of electrification projects or any potential costs. It is anticipated that this work will be undertaken following the TDNS as part of a suite of regional decarbonisation strategies. Where potential future train services have been planned via unelectrified parts of the network as part of the WCSSA testing, an appropriate rolling stock type as has been assumed to ensure the validity of run times and therefore the utilisation of rail capacity.

¹⁸ Network Rail (2020) Traction Decarbonisation Network Strategy: Interim Programme Business Case (available [online](https://www.networkrail.co.uk/wp-content/uploads/2020/09/Traction-Decarbonisation-Network-Strategy-Interim-Programme-Business-Case.pdf#:~:text=The%20purpose%20of%20the%20Traction%20Decarbonisation%20Network%20Strategy,reduction%20of%20direct%20rail%20traction%20greenhouse%20gas%20emissions.), at: <https://www.networkrail.co.uk/wp-content/uploads/2020/09/Traction-Decarbonisation-Network-Strategy-Interim-Programme-Business-Case.pdf#:~:text=The%20purpose%20of%20the%20Traction%20Decarbonisation%20Network%20Strategy,reduction%20of%20direct%20rail%20traction%20greenhouse%20gas%20emissions.>)

Any changes to traction types resulting from extraneous electrification projects, combined with an uplift in either passenger and/or freight service in future, will have a consequent impact on power supply. Testing power supply impacts is not in scope for this work, but the findings will feed into Network Rail's regional Traction Power Supply Strategy.

Recommendations following on from the analysis provided in this report which impact on decarbonisation and traction power supply have been captured in section 6 of this report.

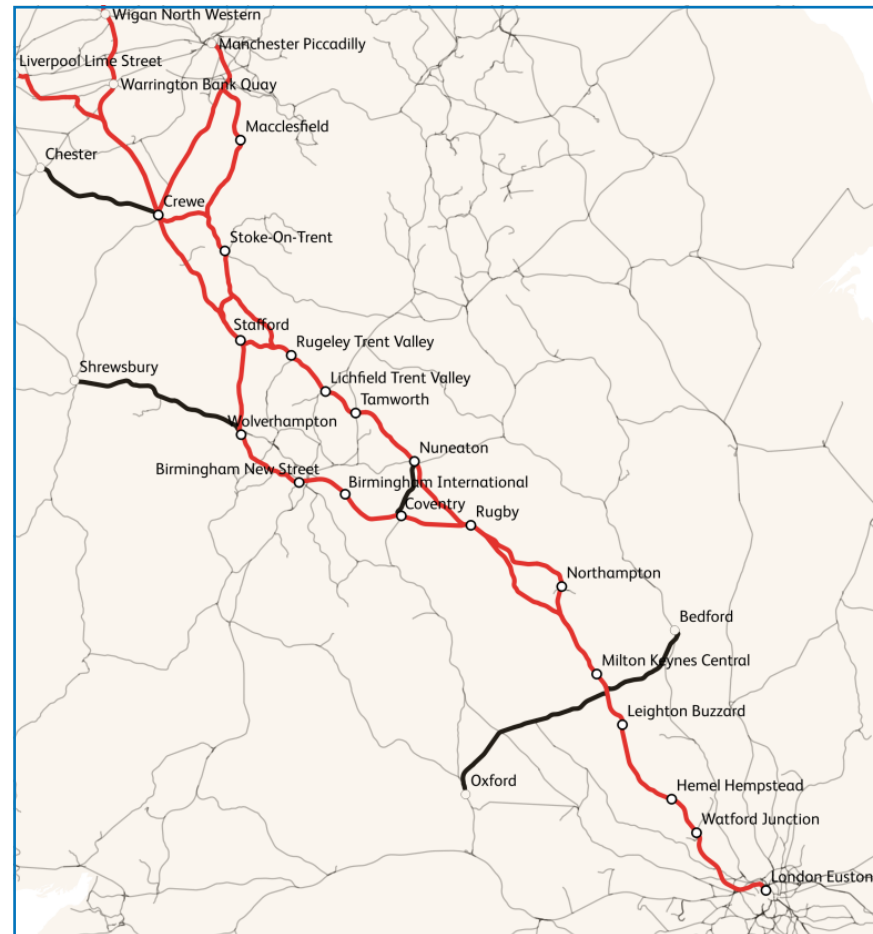

Figure 6: West Coast South electrification map, including primary interfacing routes over which future passenger services identified in this report could run.

Rolling Stock and Operations

WCSSA does not make any specific recommendations on rolling stock procurement, nor does it attempt to map train service groups to specific operators. It is an **operator agnostic** workstream in which train paths have been tested based purely on the needs of the network within a given scenario.

For the purposes of the construction of Indicative Train Service Specifications and the testing WCSSA has split passenger service types into three categories:

Intercity	Longer distance, limited-stop services which call at principal urban locations on the West Coast South route. This service group type is intended to provide intercity-type connectivity for major markets which will not be directly connected by HS2.
Interregional	Short-to-medium distance services which provide connectivity between major urban centres and other less populous locations across the route.
Local	Short distance services calling at most or all stops primarily on suburban corridors in the West Midlands in into London Euston.

Local services operating entirely in the West Midlands have not been tested per the scope of this workstream. These are covered by Network Rail’s West Midlands Strategic Advice with which the outputs of this report are aligned. No changes have been tested to London Overground services via the DC lines or Caledonian Sleeper services operating into Euston. It is assumed that these services are assumed to operate in the same quantum as today and have been included in the concept train plan analysis as such.

The distinction between the passenger service group types above is designed to give clarity on the types of markets that West Coast South route can support and serve following introduction of HS2 services, without making any determination on specific operators or contracts. However, some general recommendations - based on the results of the analysis undertaken in this work - which relate to long-term rolling stock procurement and the basic operator geography on the route have been captured in section 6 of this report.

WCSSA does not make any specific recommendations on the procurement of freight locomotives or wagon types. Instead, it has tested future available capacity for freight – across multiple scenarios – based on a set of broad assumptions around freight traction type, length, and trailing loads:

<p>Class 4</p>	<p>Freight that has been planned to operate at 775m in length with a trailing load of 1800t as standard at up to 75mph.</p>
<p>Class 6</p>	<p>Freight that has been planned to operate at 450m in length with a trailing load of 2600t as standard at up to 60mph</p>
<p>Class 1</p>	<p>‘Express logistics’ freight will be planned to operate at 250m in length with a load of 600t.</p>

Likewise, it is assumed that long-term freight operations on West Coast South will be made primarily under electric traction per Network Rail’s Traction Decarbonisation Network Strategy (TDNS). These assumptions amount to a realistic view of long-term freight operation based on existing policy and strategy. If the objectives laid out in the Traction Decarbonisation Network Strategy (TDNS) are not met and diesel freight operation continues beyond the 2040s on West Coast South, some of the capacity analysis findings in WCSSA may need to be revisited given the difference in performance and run times for diesel and electric freight locomotives.

The benefit associated with longer, heavier, and more powerful freight services are considered in more detail throughout this report. Long-term implications, including the potential impact on network capacity, power draw and supply, as well as development of infrastructure enhancements, are captured in the recommendations in section 6.

HS2 and Released Capacity

Network Rail, in coordination with the DfT, HS2 and the wider industry, has defined a series of configuration states which describe anticipated changes to the West Coast South train service through HS2's staged introduction. These have now replaced HS2 Phases 1 and 2A for the purposes of strategic planning as they better reflect the status of HS2's construction programme.

The configuration states are split into two; numbered states which are based on shorter term change linked to COVID recovery and the December 2022 timetable restructure, and lettered HS2 Integration States which are based on the sequenced introduction of HS2 infrastructure and associated train service change.

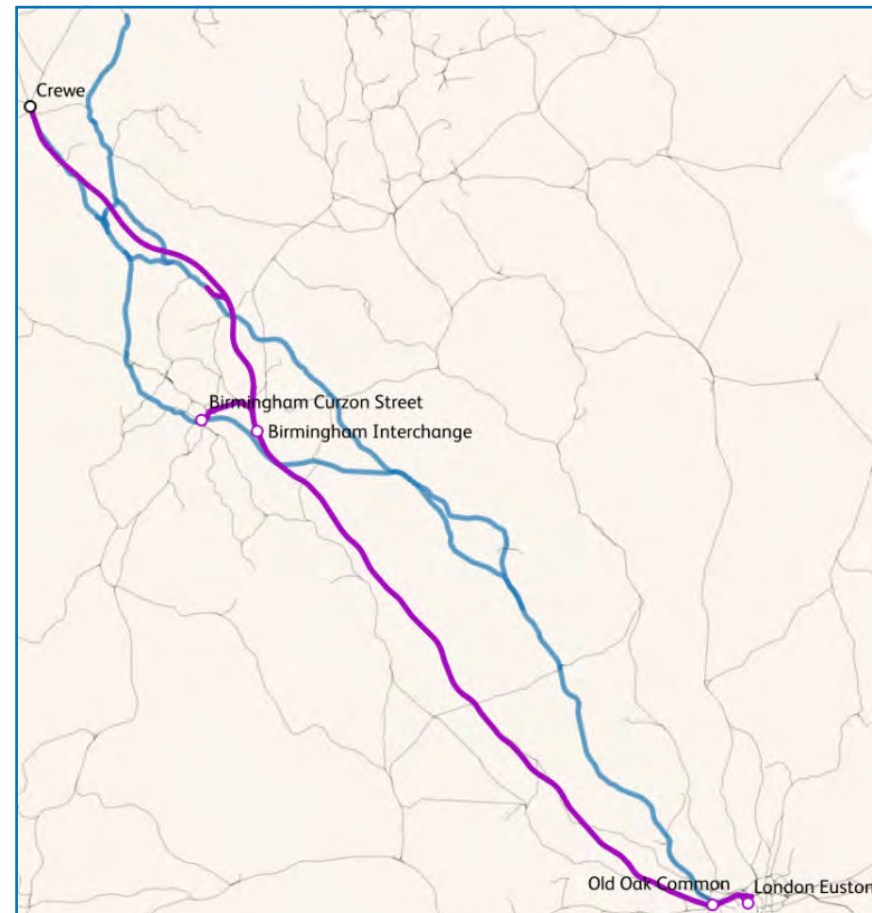

Figure 7: HS2 Configuration State G committed infrastructure (purple), comprised of the new HS2 Euston terminus, Old Oak Common, Birmingham Interchange, Birmingham Curzon Street, Handsacre Junction and Crewe South connection.

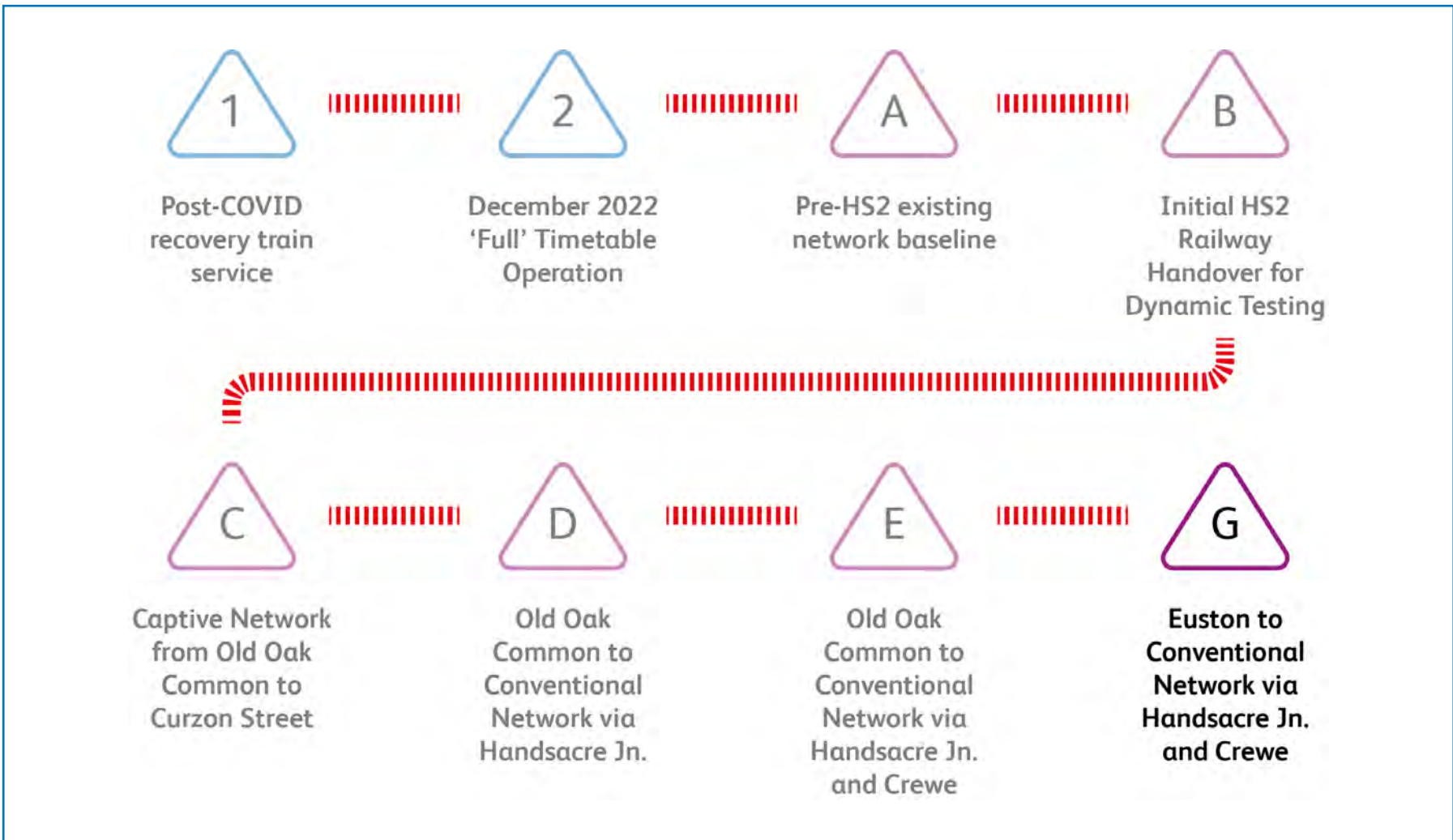

Figure 8: West Coast Main Line direction of travel configuration states, as of May 2023.

The direction of travel scenario for major train service change (shown in Figure 8) is through all configuration states except for Configuration State F, as it is assumed that a Crewe South connection will be delivered ahead of the full HS2 Euston station based on the existing programme.

WCSSA uses **Configuration State G** as a baseline, assuming as a minimum the HS2 network built in full between London and Crewe, per the specification included in the Hybrid Bill and affirmed in the Integrated Rail Plan (IRP). The assessment has not considered options for configuration states ahead of G, instead providing a focus on longer-term options which use the full extent of released capacity as a starting point. Network Rail is working with the industry to assess intervening changes at configuration states C, D and E, assuring alignment with the long term as outlined in this document.

Configuration State G implements direct high-speed services between London and Birmingham entirely on the new HS2 infrastructure, and direct 'classic compatible' services to Liverpool, Macclesfield, Manchester and Scotland via connections at Crewe South and Handsacre. Configuration State G is used as a baseline in this work on the grounds that:

- Configuration State G represents the greatest potential to release conventional network capacity within the WCSSA geographic scope through 'transfer' of Intercity Westcoast services to HS2,
- At this stage HS2 Configuration States up to Configuration State G pertain to infrastructure which now has statutory consent, with less certainty about infrastructure sequencing to follow,
- Long-term recommendations related to network capability in the Northwest is still subject to ongoing strategic assessment following publication of the IRP and so Configuration State G is used as a committed baseline.

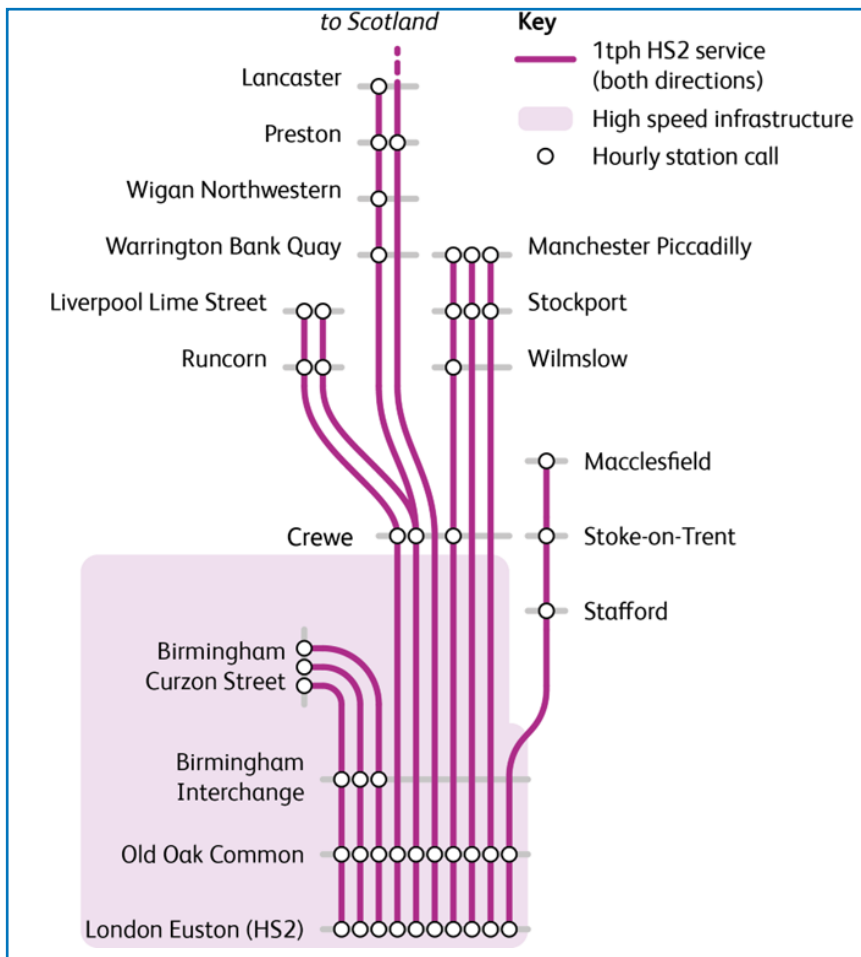

Figure 9: Configuration State G HS2 train service specification. One line represents HS2 1tph in both directions. Note, 1tph Euston-Liverpool splits at Crewe to form 1tph Euston-Lancaster.

The Configuration State G high speed train service specification (shown in Figure 9) forms a *minimum required starting point* for the analysis undertaken as part of WCSSA.

However, both the economic opportunity analysis as well as recognised industry aspirations affirm that several important intermediate passenger flows into the Northwest will remain which will require service on the conventional infrastructure. This presents a difficulty at Configuration State G given conventional network capacity will be used by additional HS2 trains coming off the high-speed infrastructure at Crewe and Handsacre Junction, potentially presenting a capacity constraint at Crewe station and through the Stockport corridor into Manchester.

However, the WCSSA workstream has considered how these conventional network train service needs could be supported in future given that the government's Integrated Rail Plan (IRP) has committed in full to the HS2 Phase 2B infrastructure between Crewe and Manchester (shown in Figure 10), and the legislation to provide it is now moving through Parliament. There may be potential to more fully utilise the capacity released by HS2 beyond Configuration State G once a fully segregated high-speed network between London, Birmingham and Manchester is in operation, as well as any conventional network enhancements which generate further capacity on the urban network in Greater Manchester.

At present, the route between Crewe and Manchester is being considered as part of a provision Configuration State H which is

anticipated to be completed several years after entry into service of Configuration State G high speed services. The required infrastructure for Configuration State H consists of a fully segregated high speed tunnel under Crewe station and a high speed alignment into a new HS2 Manchester Piccadilly Station (planned to be built immediately to the east of the existing conventional station) via a new HS2 station at Manchester Airport. The proposed Configuration State H route is shown in full in Figure 10.

Once completed the Configuration State H infrastructure will provide a fully segregated route for all high speed services into Manchester, relieving capacity through the Stockport corridor on the conventional network, as well as providing sufficient capacity for direct high speed services from Birmingham. The currently planned service specification for the Configuration State H high speed network is shown in Figure 11. As with Configuration State G, the DfT and rail industry will continue to assess options for the HS2 service specification though the removal of classic-compatible HS2 services from the Stockport corridor will free some capacity in south Manchester regardless.

It is anticipated that the findings and recommendations of this WCSSA report can act as useful inputs into ongoing strategic assessment which is testing capacity or developing enhancement options in the Northwest for the long-term, and so the recommendations in the report are not limited entirely to a Configuration State G baseline.

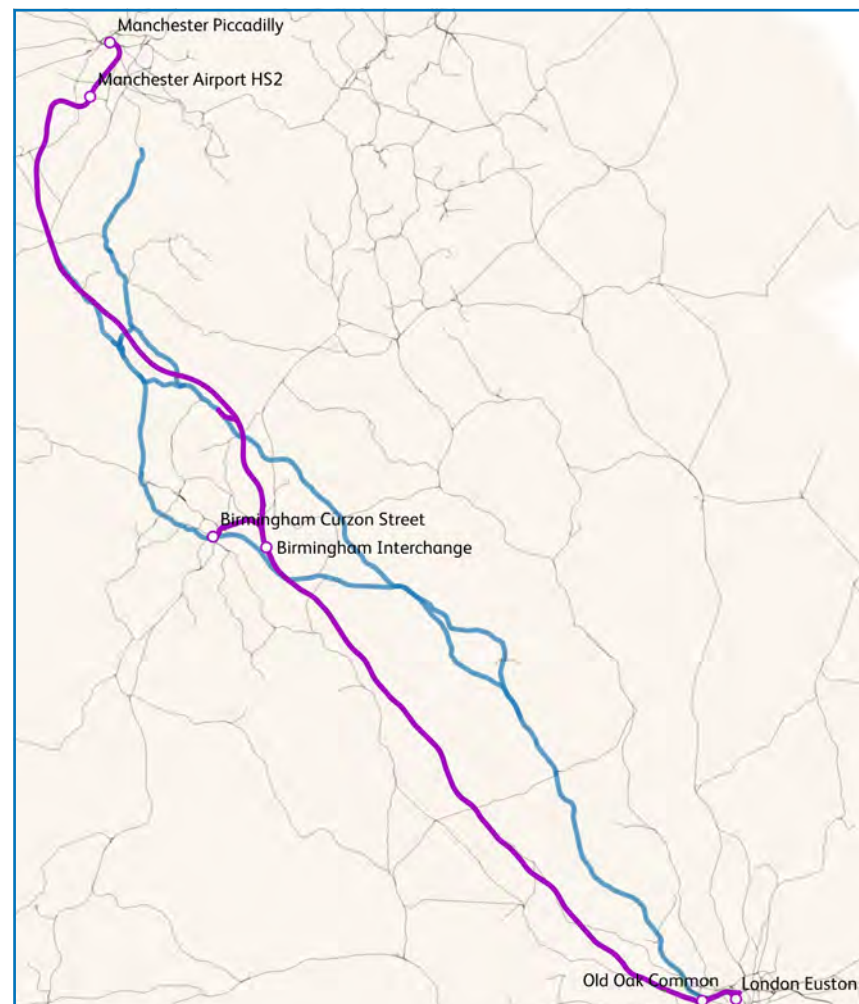

Figure 10: HS2 Phase 2B Crewe-Manchester, including the proposed Manchester Airport and Manchester Piccadilly HS2 stations.

The recommendations made in this WCSSA report on utilising released capacity assume a Configuration State G train service specification as a minimum, but also consider where conventional train services could utilise capacity released by HS2 at Configuration State H or by any further network infrastructure enhancements in the Manchester area which unlock further capacity over the longer term.

West Coast South Strategic Advice has not tested any changes to the HS2 service specification outlined above, as the scope of this work relates to the future of the conventional network infrastructure. However, where a change in the assumed HS2 service specification would have a significant impact on the structure of the conventional service this has been recorded in the narrative and summarised in the recommendations.

It is recognised that West Coast Partnership Development (WCPD) are currently remitted to assess further, more detailed options for HS2 services at Configuration State G. This may alter some of the connectivity impacts associated with high-speed services, but will not significantly impact the quantum of capacity released on West Coast South Route. Network Rail continues to work collaboratively with WCPD to manage the staged introduction of HS2 services through all identified configuration states, and maximise the benefits associated with released capacity.

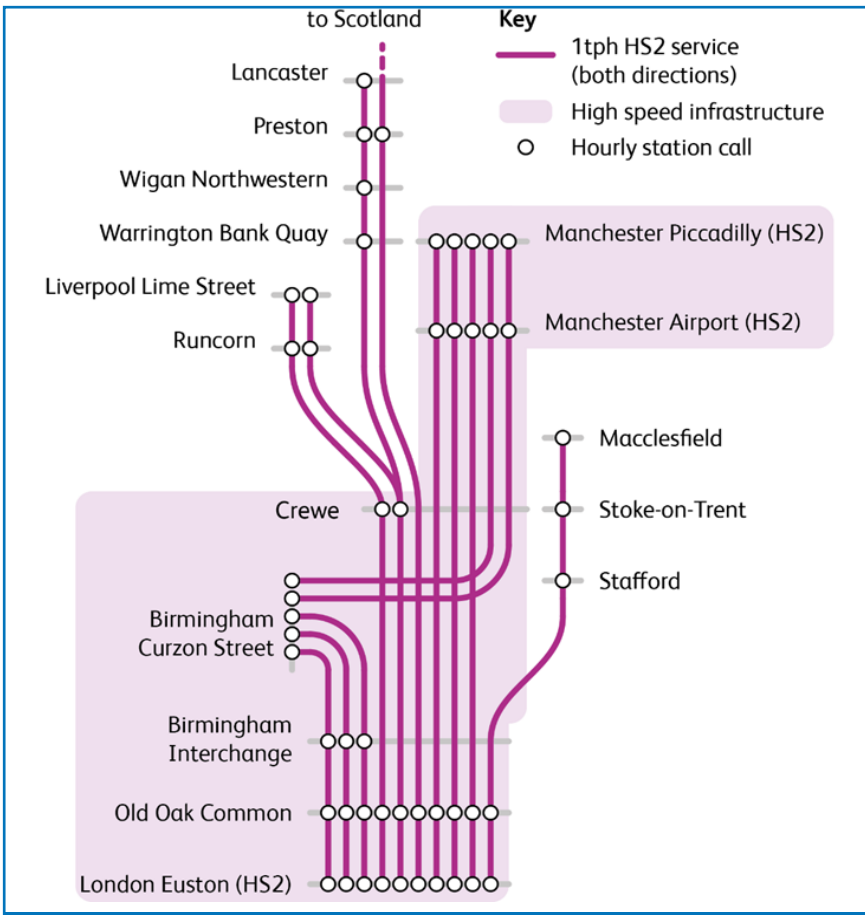

Figure 11: Configuration State H HS2 train service specification. One line represents HS2 1tph in both directions. Note, any services changes on West Coast Main Line North will be subject to further decisions on scope at Crewe and alternatives to Golborne, as outlined in the Integrated Rail Plan.



Pre-HS2 Network Baseline and Released Capacity Assumptions

The case for building the high-speed network is predicated both on agglomerating major national urban centres through higher speed and greater capacity trains, as well as releasing track capacity for service improvements on the conventional network. Accordingly, an assumption must be made on the quantum of train services which are released from the conventional network in the 'pre-HS2 network baseline' to the high-speed network. This defines the extent of the conventional network capacity released by HS2 and therefore the potential to utilise it differently in future. The pre-HS2 network baseline refers here to the conventional train service assumed to be in operation before the introduction of any HS2 train services. The WCSSA analysis has been undertaken on the basis that:

For the purposes of this work the pre-HS2 network baseline is assumed to be the December 2022 timetable which has been used as a basis to derive requirements for a comparable level of service for locations which will need to retain existing connections in the post-HS2 period. Timetable change in the intervening period could alter the pre-HS2 network baseline, and therefore assumptions about a comparable level of service. This is unlikely to significantly alter the inputs into the WCSSA work as the conventional infrastructure is largely at capacity now and so there is limited scope to introduce connectivity requirements which haven't already been captured in the Planning Principles outlined in section 5 of this report.

Train paths in the pre-HS2 network baseline which have the same origin/destination as those in the HS2 Configuration State G service specification will be assumed to be released from the conventional network infrastructure upon entry into service of HS2.

This work accordingly assumes that nine of the ten standard hourly intercity paths out of London Euston planned in the pre-HS2 network baseline are released to the high-speed network. At Configuration State G neither London-Chester nor Birmingham-Scotland will be served directly by HS2 and so these hourly intercity paths have been retained in WCSSA ITSSs.

Releasing the remaining London-Chester service would require electrification between Crewe and Chester to enable high speed trains to reach Chester and may require further works at Chester. Releasing Birmingham-Scotland services is dependent on provision of a Golborne Link as part of HS2 Phase 2B, options for which are currently being assessed following deferral in the IRP of the previously planned link. This has not been tested within this report given the scope of this work, though it is considered in the final recommendations in section 6 of this report.

It is assumed for the purposes of this work that a conventional, limited stop service will be required in all scenarios between Chester and London Euston, and between Birmingham New Street and Glasgow/Edinburgh. The overarching released capacity assumptions are provided in Figure 12, which shows the pre-HS2 network baseline train service specification in full, with services which are assumed within the WCSSA study to be *released* to the high-speed network faded out.



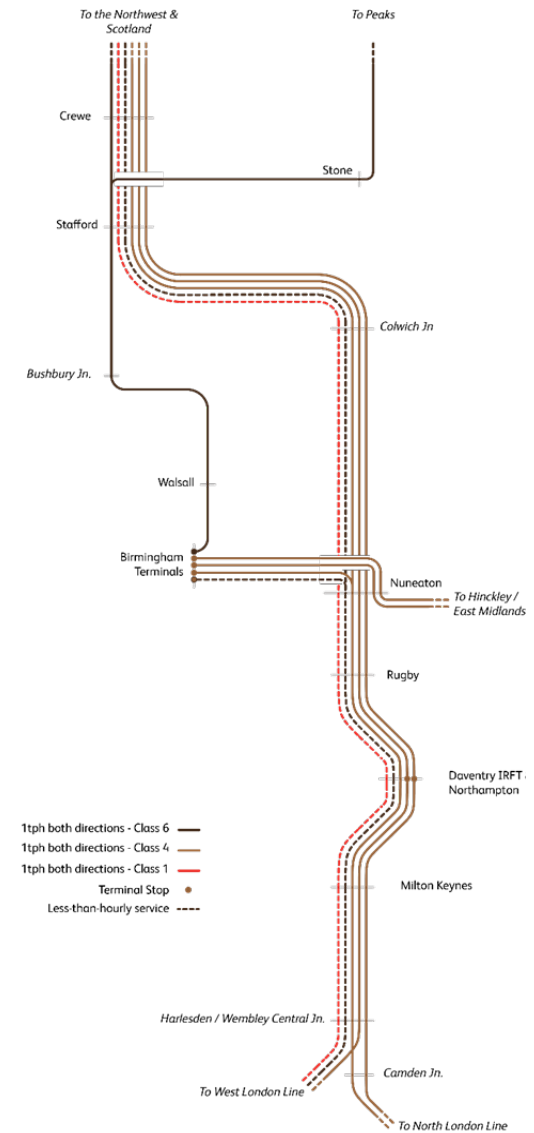
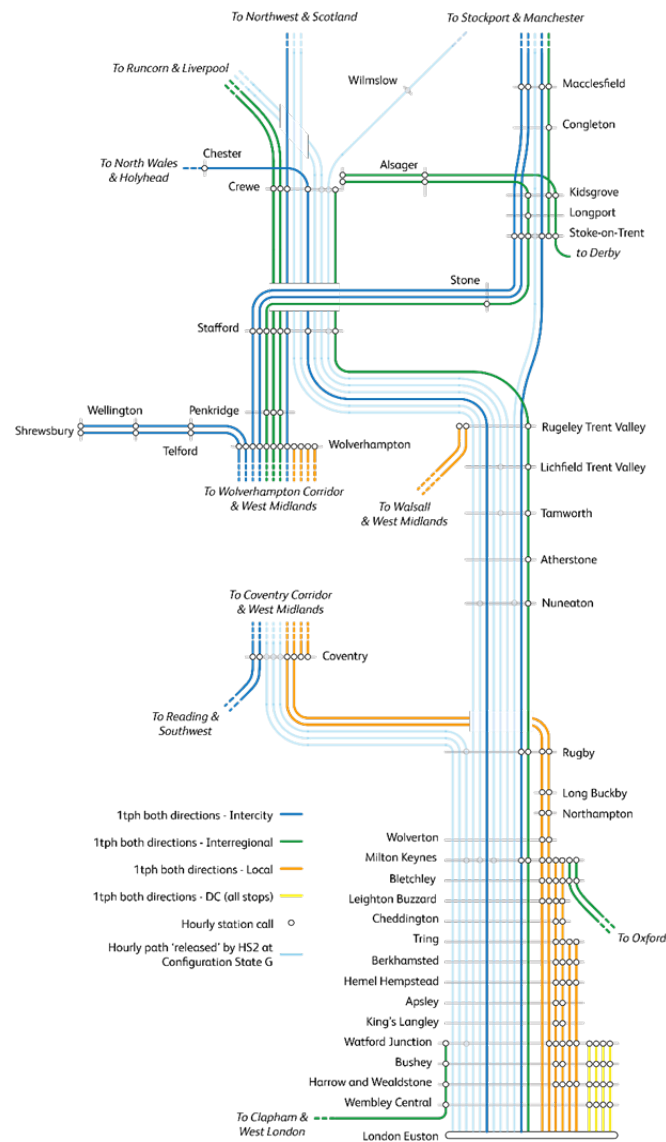

Figure 12: West Coast Main Line South December 2022 timetable structure.

Each line represents 1 train per hour in both directions. Passenger services are shown on left, freight on the right.

Train paths which are shown as light blue and translucent are assumed to be 'released' by HS2 at Configuration State G, with headline connections between London, Birmingham, Liverpool, Manchester and Scotland made on the high-speed infrastructure instead.

Serving ‘Intermediate’ Markets

Transferring train paths from the conventional network to HS2 based on origin/destination pairs as described above could risk loss of connectivity for places which are currently served by Intercity Westcoast trains. For example, as shown in Figure 12, if London-Birmingham services are ‘transferred’ to the high-speed network – and those paths are released per the assumptions outlined above – Watford, Milton Keynes, Rugby and Coventry would also lose connectivity both between each other, and to both London and Birmingham in every instance.

There is then a need to provide a comparable level of service to today for those intermediate markets; namely, places which are currently well connected with intercity-type service in the December 2022 timetable and will need to retain it but will not be connected directly by the high speed network.

It is also important that the potential for improvement and growth of intermediate markets is supported over the long-term. This is reflected in the baseline Planning Principles outlined in section 5 – which determine a minimum required service levels for a set of intermediate locations – and has been assessed throughout the scenario testing. Consideration has been given throughout the analysis to the long-term strategic need to support intermediate markets confined entirely to West Coast South route (e.g. Milton Keynes and Stoke-on-Trent), and between non-HS2 West Coast South locations and major urban centres on the high-speed network (e.g. Coventry and London, or Watford and Manchester).

Ultimately, HS2 will release significant track capacity to provide improved conventional network connectivity between a range of origins and destinations. As the results of the analysis demonstrate, this must be weighed up against providing a comparable level of intermediate connectivity and limited-stop service. There are likely to be acute trade-offs driven by this issue at Coventry – where it is unlikely that the same quantum of limited stop services to London can be sustained – and at Stoke-on-Trent where connectivity to London and Milton Keynes may be impacted by the interaction at Stoke between the conventional and planned HS2 classic-compatible services. These issues are considered specifically within the recommendations of this report.

Conventional Network Schemes in Development

There are several important conventional network infrastructure schemes currently in development or delivery which could impact the use of capacity on West Coast South route. The assumptions on what each of these schemes will deliver as currently planned is outlined below.

The potential to maximise integration with between these schemes (and associated trade-offs or infrastructure requirements) based on these assumptions is explained in the testing results and recommendations in sections 6 and 7 of this report respectively.

Midlands Rail Hub

The Midlands Rail Hub project is a major rail scheme that will transform the regional rail network by providing additional intercity services between the East Midlands, West Midlands and southwest, as well uplifting passenger service at Birmingham Moor Street and consequently improving connection to the high-speed network via the HS2 Curzon Street station.

This transformation is achieved through multiple major infrastructure interventions across the West Midlands network, including provision of two chords (east and west-facing) in the Bordesley area as well as expanded platform capacity at Birmingham Moor Street and Birmingham Snow Hill stations.

While the concept train plans developed as part of the West Coast South Strategic Advice workstream do not require the interventions delivered as part of the Midlands Rail Hub scheme, they are aligned to the long-term train service specification described as part of Network Rail's published West Midlands Strategic Advice. The released capacity train service structure through the West Midlands via Coventry, Birmingham and Wolverhampton which features in all WCSSA scenario ITSSs is aligned to the corresponding direction of travel for the urban network in the West Midlands.

Further, the requirements which have been used to construct WCSSA ITSSs have reflected the opportunity for improved interchange at interfacing points on the West Coast South and West Midlands network. This is due to anticipated service optimisation on the Coventry and Wolverhampton corridors, as well as the long-term potential for improved interchange with Birmingham's radial corridors at Nuneaton, Tamworth and Lichfield.

East West Rail

East West Rail is a major infrastructure programme delivering, in stages, a new two-track main line between Oxford, Aylesbury and Cambridge. The programme has been split into 'connection stages' which are currently at different points in the development cycle.

Table 3: East West Rail programme connection stages and assumed infrastructure.

Connection Stage 1	Reinstatement of the two-rack railway from Oxford to Bletchley via the Bletchley flyover, connecting into West Coast South at Denbigh Hall South junction.	Delivery
Connection Stage 2	Enhancement of the Marston Vale line between Bletchley and Bedford to two-track main line standard.	Develop
Connection Stage 2.5	Enhancement of the existing line between Aylesbury and Claydon junction, connecting to the connection stage one infrastructure between Oxford and Bletchley.	Develop
Connection Stage 3	Construction of an entirely new two-track alignment between Bedford and Cambridge via a new interchange station on the East Coast Main Line. ²⁰	Develop

The East West Rail programme will also deliver new stations which will support the creation of an inter-urban commuter railway, transforming generalised journey times and encouraging modal shift across the region between Oxford and Cambridge.²¹

The train services which are planned for delivery at each connection stage are outlined below:

Table 4: East West Rail programme train service specifications.

Connection Stage 1	Half-hourly passenger services Oxford-Milton Keynes Up to two-hourly freight services Southwest-WCML	December 2024
Connection Stage 2	Passenger Services Oxford - Bedford	TBC
Connection Stage 2.5	Passenger Services to/from Aylesbury	TBC
Connection Stage 3	Passenger Services to/from Cambridge	TBC

²⁰ The East West Rail Company May 2023 update on the preferred route for between Oxford, Bedford and Cambridge can be found at: [East West Rail | Route Update](#) Announcement

²¹ East West Rail Company (2022) Factsheet: EWR Co and the EWR Project (available [online](https://eastwestrail-production.s3.eu-west-2.amazonaws.com/public/Uploads/271009259b/EWR-Co-and-Project5.pdf), at: <https://eastwestrail-production.s3.eu-west-2.amazonaws.com/public/Uploads/271009259b/EWR-Co-and-Project5.pdf>)

At present, the programme is not remitted to deliver electrification or any service extensions on to existing main lines beyond what is described in Table 4. Network Rail’s high-level position on the long-term use of the East West Rail infrastructure is outlined in its East West Main Line Strategic Statement²² which presented a long-term ‘vision’ based on service extensions and fuller integration with the existing main line network. The WCSSA work has considered how to achieve this vision, exploring train service and enhancement options which support integration with West Coast South route in the long-term.

The principles and findings articulated by this report have assumed that the East West Rail programme between Oxford, Aylesbury and Cambridge outlined above will be delivered per the existing remit. Nothing produced as part of this report undermines the case for the currently remitted programme or requires change to the existing scope beyond recommendations for non-preclusion.

However, this report does make recommendations – based on the findings of the analysis undertaken - linked to East West Rail which may support the case for further investment, expansion of scope or more fully integrating the East West Rail through infrastructure enhancement on West Coast South route. Findings and recommendations are outlined in sections 6 and 7 of this report respectively.

²² Network Rail (2022) ‘East West Main Line Strategic Statement’ (available [online](https://sacuksprodnr.digital0001.blob.core.windows.net/regional-long-term-planning/North,%20West%20and%20Central/East%20West%20Main%20Line%20Strategic%20Statement%202022.pdf), at: <https://sacuksprodnr.digital0001.blob.core.windows.net/regional-long-term-planning/North,%20West%20and%20Central/East%20West%20Main%20Line%20Strategic%20Statement%202022.pdf>)

Felixstowe to Midlands and the North

The WCSSA workstream has also tested the potential for released capacity and conventional network enhancements to support freight growth. The specific approach to freight forecasts and national routings, and how this has been translated into a freight train service specification in this work, is explained in section 5 of this report.

A key feature of all freight operations however is the national scale and cross-boundary nature of routes. Long-term utilisation of capacity on West Coast South for uplifted freight will require the unlocking of additional freight routes given that growth in demand from Thameside ports can only realistically be provided on West Coast South via London.

This drives a consequent need to provide alternative routing options which support freight growth from the East of England and the port of Felixstowe to the Northwest and the ‘Golden Triangle’ of logistics in the Northamptonshire / Midlands area. The Felixstowe to Midlands and the North (F2MN) scheme is a proposal to deliver a staged set of infrastructure enhancements from the port of Felixstowe, through the Ely area and ultimately via the East Midlands and North Staffordshire line.

The overall scheme builds on a series of completed enhancements, including; Peterborough-Nuneaton gauge clearance, Nuneaton north chord, Ipswich north chord, Ipswich

Table 5: Felixstowe to Midlands and the North (F2MN) infrastructure scope and nominal stages.

Felixstowe to Cambridge	Doubling Haughley Junction and Bury St. Edmunds linespeed improvements.	Delivery
	Warren Hill tunnel gauge clearance and Newmarket level crossing/capacity upgrades	
	<i>Required for freight via East West Rail</i>	
Ely to Nuneaton	Ely area and Soham bridge structure, signalling and capacity enhancements	Develop/Determine
	Peterborough to Leicester level crossing upgrades	
	Leicester area capacity enhancements	
Syston to Stoke	Syston to Stoke-on-Trent gauge clearance works	Develop/Determine

yard remodelling, and Felixstowe branch capacity improvements. In total, F2MN could deliver between 40-60 additional freight trains per day in line with long-term forecasts for demand for intermodal and container traffic.

However, it is recognised that new routing options can be created in stages depending on the interventions delivered (outlined in this section) and alignment with the East West Rail programme.

East West Rail connection stages 2 and 3 will provide infrastructure that is gauge cleared (to W12) for all intermodal freight, offering an alternative route for traffic via Felixstowe. Options to route freight from Felixstowe to West Coast South via East West Rail have been explored in this report per Network Rail’s East West Main Line Strategic Statement, its London Rail Freight Strategy²³, and the expressed aspirations stakeholders in the freight sector. This work considers what train service and infrastructure options are available in the long-term to effectively uplift the level of freight operation on West Coast South route and the extent to which this requires the enhancements associated with the F2MN scheme.

The findings and recommendations related to freight capacity on West Coast South, and the potential for released capacity and infrastructure enhancement to support freight growth and routing options, are captured in sections 5 and 6 of this report.

²³ Network Rail (2020) London Rail Freight Strategy Executive Summary (available [online](https://www.networkrail.co.uk/wp-content/uploads/2021/05/London-Rail-Freight-Strategy-Summary-Report.pdf), at: <https://www.networkrail.co.uk/wp-content/uploads/2021/05/London-Rail-Freight-Strategy-Summary-Report.pdf>)

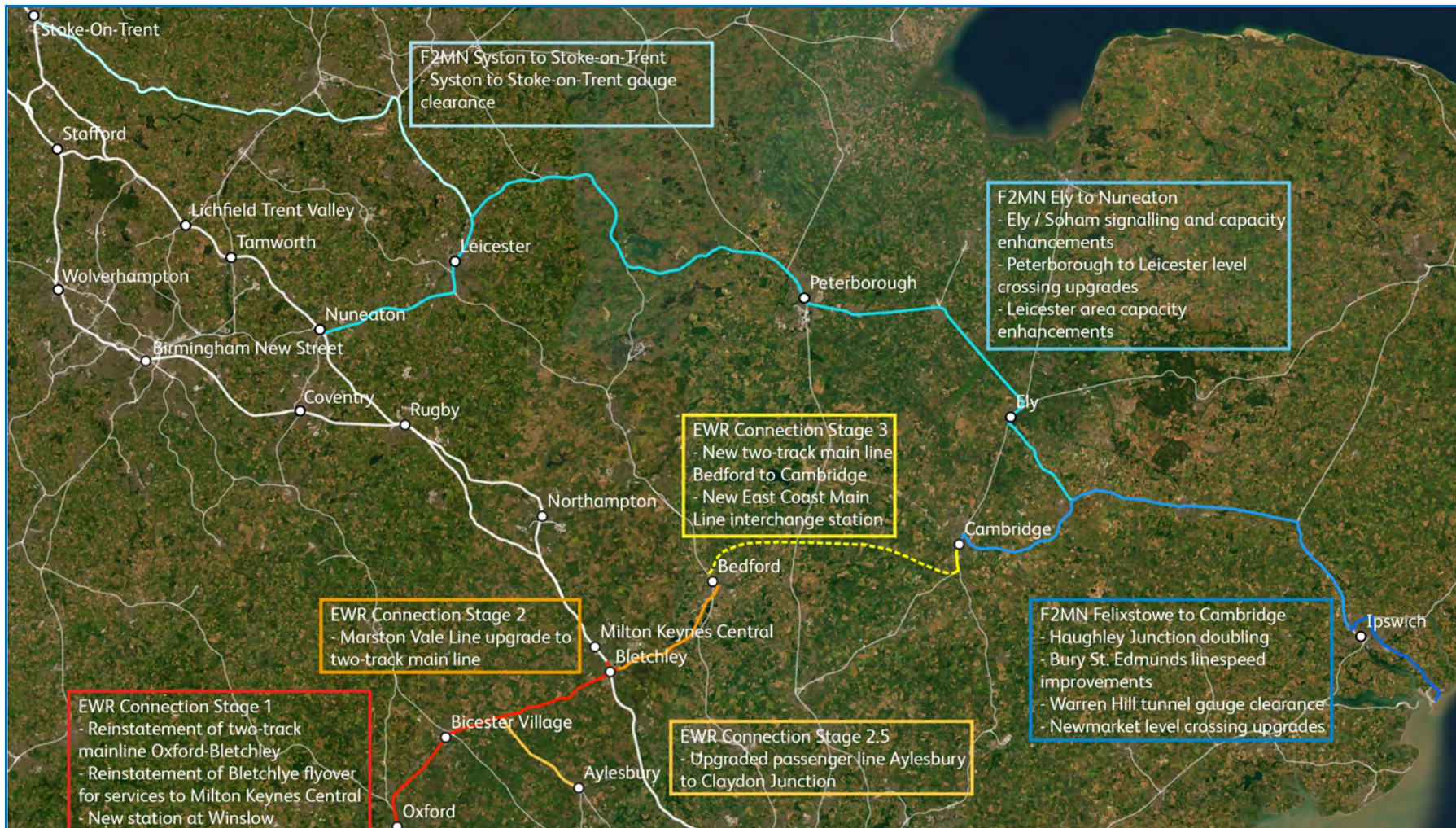

Figure 13: East West Rail (EWR) and Felixstowe to Midlands and the North (F2MN) route map and enhancements, including points of interface with West Coast South route. The EWR Connection Stage 3 route Bedford to Cambridge will be a new alignment which has yet to be confirmed. Satellite imagery copyright ARCGIS, Esri, Maxar and Earthstar Geographics.

Euston Station

There are several interfacing schemes and aspirations for London Euston conventional station which could impact directly on long-term network capability on West Coast South route. These include the ongoing works associated with the construction of the adjacent HS2 Euston Station (managed jointly by HS2 and Network Rail's On-Network Works team) as well as the long-term, post-HS2 Redevelopment of Euston Conventional Station (RECS) scheme.

In the short term, the HS2 station construction requires some of the footprint of the existing conventional station. The former platforms 17 and 18 have been permanently abandoned and handed over to HS2. As part of ongoing construction, HS2 will also temporarily take platforms 15 and 16 at the conventional station out of use, re-providing them to same length and physical specification in the space of the existing middle sidings. Platform 16 must be re-provided before the entry into service of HS2 services to support the reliable operation of the full pre-HS2 network baseline timetable.

Following completion of the HS2 Euston station and the operation of the Configuration State G train service, the RECS programme is planned to undertake a rolling construction programme to redevelop the conventional station. The project is currently at the Strategic Outline Business Case stage, with work ongoing to develop a design and construction plan which could involve temporary platform closures as well as a permanent reduction in the number of platforms through combination of the short platforms 9 and 10.

Given the stage of maturity of this scheme, WCSSA has assumed a layout at Euston conventional station based on what is currently known and committed; that is to say, **a sixteen-platform layout with platform lengths and specifications per those shown in the Sectional Appendix as of December 2022**. The nature of the train planning work undertaken - testing train services over a stand hour – means that removal of the middle sidings between platforms 15 and 16 will not have a material impact on the results and the recommendations in this report. This change is being managed by Network Rail and HS2 in consultation with the wider industry as part of the existing sponsored programme.

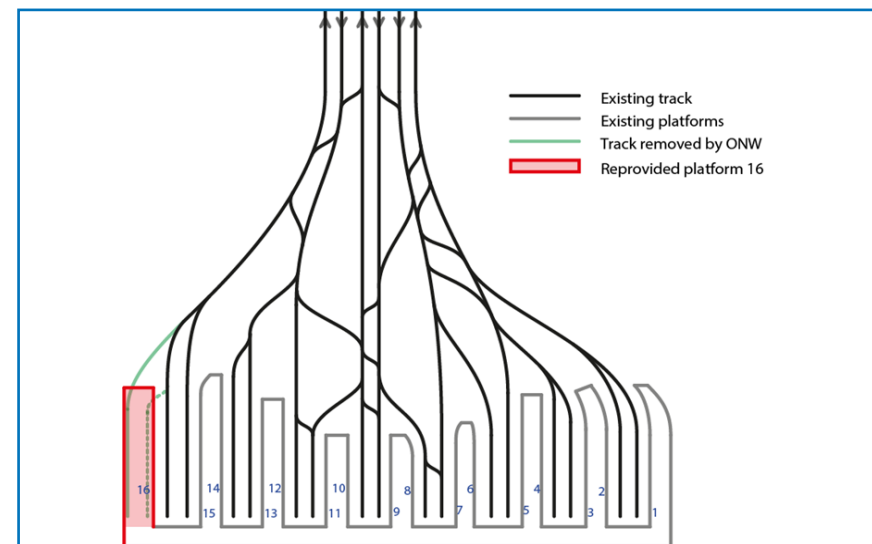

Figure 14: London Euston conventional station layout assumed in WCSSA. Platform 16 re-provided in the footprint of the existing middle sidings from 2025.

Planning Principles



The construction of the scenario ITSSs in WCSSA has been guided by the outputs of an economic opportunity analysis (which identified priority flows against each of the study's guiding objectives) as well as known industry aspirations based on stakeholder organisations' economic and strategic evidence. As a first step however, the results of the economic opportunity analysis have been used to determine a series of Planning Principles which govern the construction of all scenario ITSSs tested in the workstream. These principles define a target service level or operational change that is considered significant enough to be included in all scenarios and is therefore prioritised in the train planning activity.

The planning principles have been determined primarily by the results of the economic opportunity analysis, but also based on:

- Fit within the wider economic/demographic geography and trajectory of the route,
- The growth potential of key urban areas on the route and the need to support it,
- Strategic fit with committed and in-development rail schemes and the wider network,

Other stakeholder aspirations for long-term service improvement. The Planning Principles are outlined in the following subsections. Taken together they give Network Rail's position on what the

post-HS2 train service on West Coast South route should seek to deliver as a minimum.

All of the requirements explained in the following pages, and therefore the outputs and recommendations of this work, are aligned to the Government's strategic aims for HS2 as articulated in the 2013 statement of Strategic Case²⁴, including:

- Provision of a 'broadly comparable or better' service for all places currently connected to London after HS2 opens,
- Provision of additional commuter capacity where it is most needed,
- Spreading the benefits of long-distance and inter-regional services to the many towns and cities that can be served by the capacity created on the existing rail network,
- Full integration of HS2 services into the wider national rail network,
- Provision of capacity for growing the rail freight sector,
- Improving performance by making timetables more robust.

The Planning Principles outlined and the findings of the WCSSA workstream provide an up-to-date assessment on achieving these aims for the West Coast Main Line South route section.

²⁴ Department for Transport (2013) 'The Strategic Case for HS2', p75 (available [online](https://assets.publishing.service.gov.uk/government/uploads/system/uploads/attachment_data/file/260525/strategic-case.pdf), at: https://assets.publishing.service.gov.uk/government/uploads/system/uploads/attachment_data/file/260525/strategic-case.pdf)

Planning Principle A: Supporting Freight Growth

It is recognised that rail freight is a key contributor to all the objectives set for the WCSSA work. Over £30 billion worth of goods are transported by rail each year, contributing £2.5 billion in economic benefits to the national economy (£1.6 billion to rail customers by reducing the cost of transporting goods, and £0.9 billion to wider society through removal of road traffic)²⁴, in addition to generating numerous wider social and user benefits, as identified in recent work by Deloitte.²⁵ A single freight train can remove approximately 76 Heavy Goods Vehicles from the road²⁶, demonstrating the opportunity available in encouraging modal shift from road to rail per the Government's commitment to achieve net-zero carbon emissions by 2050, and with even greater imperative in light of its Transport Decarbonisation Plan (TPD)²⁷ and Network Rail's Traction Decarbonisation Network Strategy (TDNS)²⁸.

The West Coast Main Line is a critical strategic route for freight providing, in addition to moderate levels of construction and aggregates traffic, a key artery for intermodal flows from the port of Felixstowe, as well as intermodal and automotive flows from the Solent, Thameside ports and Liverpool. Many of the inland terminals for these flows are situated on or near to the WCML, including logistics hubs in the West Midlands and Northamptonshire area. West Coast South route is also a critical route for freight traffic to terminals in the Northwest and Scotland operating via the major freight yard at Basford Hall, Crewe.

²⁴ Rail Delivery Group (2018) 'Rail Freight: Working for Britain' (available [online](https://www.raildeliverygroup.com/files/Publications/2018-06_rail_freight_working_for_britain.pdf), at: https://www.raildeliverygroup.com/files/Publications/2018-06_rail_freight_working_for_britain.pdf)

²⁵ Deloitte / Rail Delivery Group (2021) 'Assessing the Value of Rail Freight' (available [online](https://www.raildeliverygroup.com/media-centre-docman/12807-2021-04-role-and-value-of-rail-freight/file.html), at: <https://www.raildeliverygroup.com/media-centre-docman/12807-2021-04-role-and-value-of-rail-freight/file.html>)

²⁶ Rail Delivery Group (2018) 'Rail Freight: Working for Britain' (available [online](https://www.raildeliverygroup.com/files/Publications/2018-06_rail_freight_working_for_britain.pdf), at: https://www.raildeliverygroup.com/files/Publications/2018-06_rail_freight_working_for_britain.pdf)

²⁷ Department for Transport (2021) 'Decarbonising Transport: A Better, Greener Britain' (available [online](https://assets.publishing.service.gov.uk/government/uploads/system/uploads/attachment_data/file/1009448/decarbonising-transport-a-better-greener-britain.pdf), at: https://assets.publishing.service.gov.uk/government/uploads/system/uploads/attachment_data/file/1009448/decarbonising-transport-a-better-greener-britain.pdf)

²⁸ Network Rail (2020) Traction Decarbonisation Network Strategy. (Available [online](https://www.networkrail.co.uk/wp-content/uploads/2020/09/Traction-Decarbonisation-Network-Strategy-Interim-Programme-Business-Case.pdf), at: <https://www.networkrail.co.uk/wp-content/uploads/2020/09/Traction-Decarbonisation-Network-Strategy-Interim-Programme-Business-Case.pdf>)

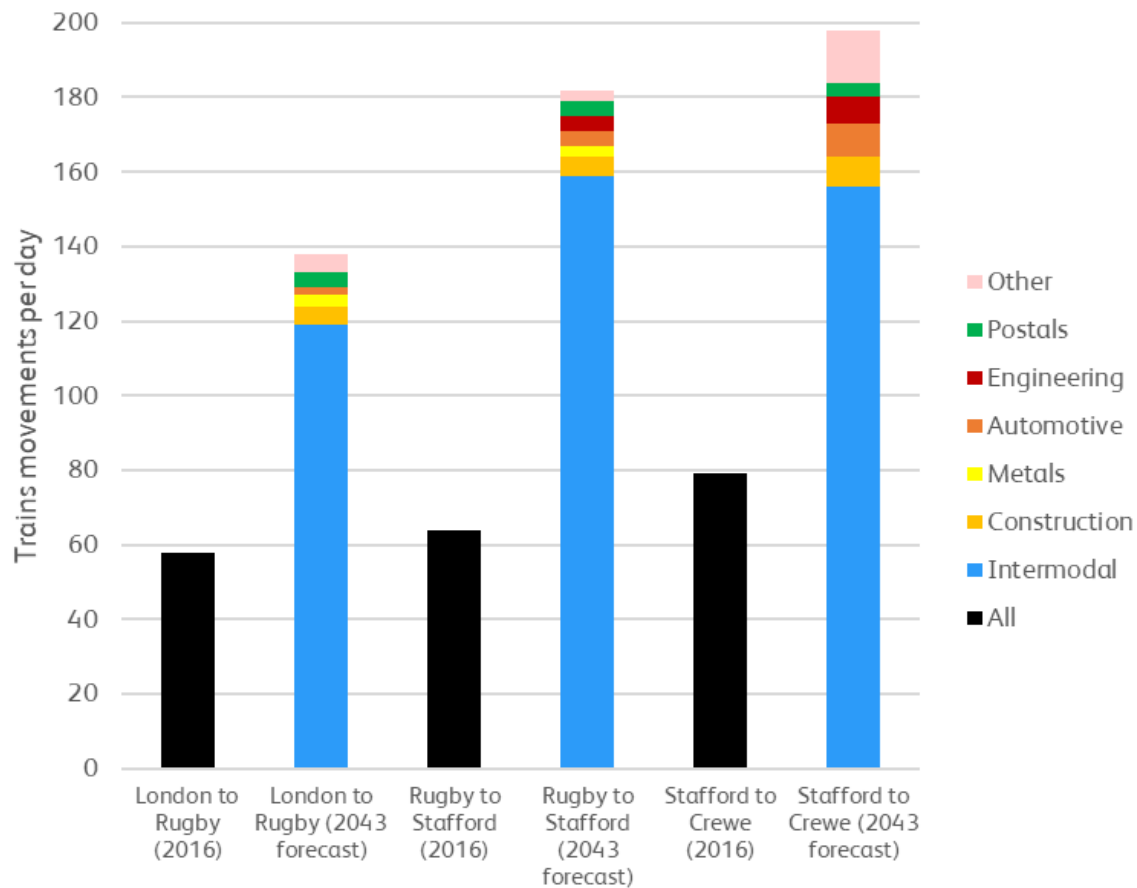



Figure 15: 2043 Scenario B 'high growth' bulk freight forecast trains per day on West Coast South trunk route sections.



The freight market is also forecast to grow significantly in the coming decades. In 2020 Network Rail and MDS Transmodal generated a set of industry-endorsed forecasts for rail freight growth to 2033 and 2043. A number of scenarios were identified and it is now Network Rail's view that the Scenario B forecasts based on "factors which favour rail to road, with high market growth" represents a realistic, high growth scenario on which to base long-term planning. In Scenario B, by 2043, rail freight tonnes moved in the construction sector is set to increase to 74,468 tonnes (3x more than today), in the ports intermodal sector to 56,596 tonnes (3.5x more than today), and in the domestic intermodal sector to 23,633 tonnes (9.5x more than today)³⁰. The increase in forecasted demand for rail freight via West Coast South route sections for 2043 is shown in Figure 15, demonstrating both the massive potential increase in demand in a high growth scenario and the relative preponderance of intermodal growth over the long-term.

³⁰ Network Rail / MDS Transmodal (2019) 'Rail Freight Forecasts: Scenarios for 2033/34 & 2043/44' (available [online](https://www.networkrail.co.uk/wp-content/uploads/2019/04/Rail-freight-forecasts-Scenarios-for-2033-and-2043.pdf), at: <https://www.networkrail.co.uk/wp-content/uploads/2019/04/Rail-freight-forecasts-Scenarios-for-2033-and-2043.pdf>)

Given that part of the strategic case for HS2 rests on releasing capacity on the conventional network for more freight, WCSSA has made testing uplifted levels of rail freight a primary focus for the work. As such, WCSSA has been undertaken in consultation with partners in the freight sector (taking into account both the strong rebound in demand for rail freight post-COVID and the government's wider emissions reductions targets), adopting the position that: 

As part of the WCSSA workstream Network Rail has translated the MDST Scenario B forecasts for 2043 into a standard hourly 'high growth' freight ITSS for West Coast Main Line south, shown in Figure 16. This has been achieved by converting anticipated trains per day demand within the MDST Scenario B forecast into hourly paths for freight across the full route geography, accounting for routing options for freight entering and exiting the scope.

All scenario ITSSs should target the MDST 2043 Scenario B levels of forecasted freight demand, making sure that an uplift beyond today's level of freight is provided in every Concept Train Plan regardless of scenario focus.

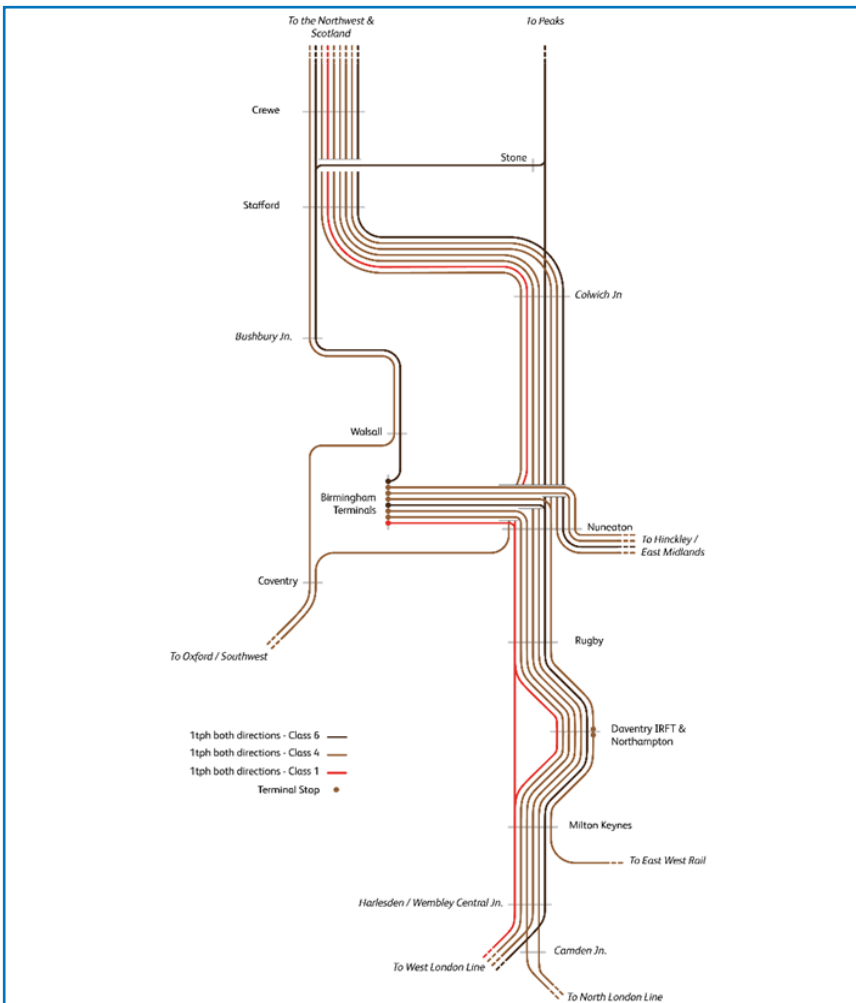

Figure 16: Central Case freight ITSS used as a benchmark for a 'high growth' level of freight via West Coast South in all scenarios.

The ITSS assumes standard hourly paths based on the average required across a 24-hour day. The ITSS also includes several 'Y paths'; that is to say, a path which is split between two or more destinations assuming that a service can run to either origin/destination pair within a given hour. This provides sufficient capacity for the anticipated level of demand without providing paths in the train plan which may not be used.

The high growth ITSS for freight has been included in every scenario. This has then been subject to capacity analysis and testing to show where trade-offs between freight and passenger service exist within the constraints of the existing infrastructure, and where infrastructure enhancement might be required to plan for prioritised freight and passenger services. It has not been possible to provide the full high growth freight ITSS in every scenario because of the competing demands on finite rail capacity and the infrastructure constraints encountered, even assuming the full capacity released by HS2. The extent of the trade-offs and infrastructure required is covered in section 6 of this report, however; **all concept train plans have provided for an uplift on today's level of freight on West Coast South route as minimum.**

To ensure that the requirements to deliver a high growth level of freight in full are understood, a *Freight Focus* scenario has tested uplifting the quantum of paths beyond the high growth level and has prioritised freight services in the concept train planning. The results of this scenario demonstrate what service trade-offs or infrastructure is required if supporting a growth in rail freight is the primary long-term objective on West Coast South route.

The utilisation of freight paths is dependent on developments outside of the WCSSA geographic scope to a greater extent than most passenger services. This is due to the nation-wide nature of freight routing which cannot be as readily limited to a regional geography as passenger service provision. As a result, WCSSA outputs identify what is required to accommodate the requisite freight in each scenario within the geographic scope only. It should be noted that further enhancement or intervention will be required to maximise the benefits for freight (per assumptions outlined above) in:

London; based on the findings of the London Rail Freight Strategy

East Anglia/East Midlands; through staged delivery of the Felixstowe to Midlands and the North (F2MN) project, to Nuneaton or via East West Rail

WCML North; through flighting and/or infrastructure to meet long-term aspirations for cross-border freight to Scotland,

It is highly unlikely that capacity for a high growth level of freight could be fully utilised with end-to-end freight paths without further investment in the above, or without significantly reworking routings for freight over the long-term. Where uplift for freight is achieved in concept train plans in this work the potential capacity limitations outside the geographic scope have been considered in the results in section 6 and have informed the recommendations in section 6.

Further, the testing undertaken in this work has also made a series of assumptions about freight operations over the long term which accord with the industry direction of travel as outlined in section 4 above, including:

Longer (775m), heavier (1800t Class 4) trailing loads which are required to utilise available capacity more efficiently

Electrically hauled freight which conforms to wider industry aspirations to decarbonise the railway

Today's gauge clearances which determine the types of traffic and containers which can operate on West Coast South route

Major infrastructure projects which include loop lengthening at freight terminals or sidings, in-fill electrification projects outside of the geographic scope, or freight gauge enhancements have not been developed as part of this work. These should be progressed on a case-by-case basis provided they conform to the general principles and findings articulated in this report.

However, assumptions around trailing loads, traction type and loading gauges will have a material impact on the ability of West Coast South route to provide for growing levels of freight. This report provides some general recommendations which follow logically from the results of the scenario testing and are aimed at maximising the potential to support future freight growth. These are captured in full in section 6 of this report.

Planning Principle B: Milton Keynes ‘Hub’

Milton Keynes is of critical importance for the long-term operation of West Coast South route. It is at present one of the largest urban areas in scope which will not be served directly by HS2 and will therefore continue to rely on the conventional network for passenger rail service. The city’s population was 269k in 2021, making it equivalent in size to other major urban areas in the WCSSA study scope area like Northampton, Wolverhampton and Stoke-on-Trent. A strong strategic location and proximity to London has helped cement Milton Keynes’ diverse economy, which is particularly strong in research, technology, and IT services. In 2019 Milton Keynes’ Gross Value Added reached £14.6bn; significantly higher than any other urban area of comparable size on the West Coast South route. It is, however, the potential for growth in Milton Keynes which marks the town out for specific status as a ‘hub’ within the context of this study. The UK Centre for Cities has recognised Milton Keynes as one of five major growth areas, with the population expected to nearly double to 500,000 by 2050. The ten-year GVA growth rate in 2019 was 75 %, the fast rate of growth of any location within WCSSA scope and the city has been consistently in the top five fastest growing UK cities between 2015 and 2020.³²

Consequently, this expansion has put significant pressure for local development and additional housing. Milton Keynes council plans

³² Centre for Cities (2021) ‘Fast Growth Cities – 2021 and beyond’ (available [online](https://www.centreforcities.org/wp-content/uploads/2021/03/fast-growth-cities-2021-and-beyond.pdf), at: <https://www.centreforcities.org/wp-content/uploads/2021/03/fast-growth-cities-2021-and-beyond.pdf>)

³³ Milton Keynes Council (2019) ‘Plan:MK 2016-2031’ (available [online](https://www.milton-keynes.gov.uk/sites/default/files/2022-05/PlanMK%20Adoption%20Version%20%28March%202019%29.pdf), at: <https://www.milton-keynes.gov.uk/sites/default/files/2022-05/PlanMK%20Adoption%20Version%20%28March%202019%29.pdf>)

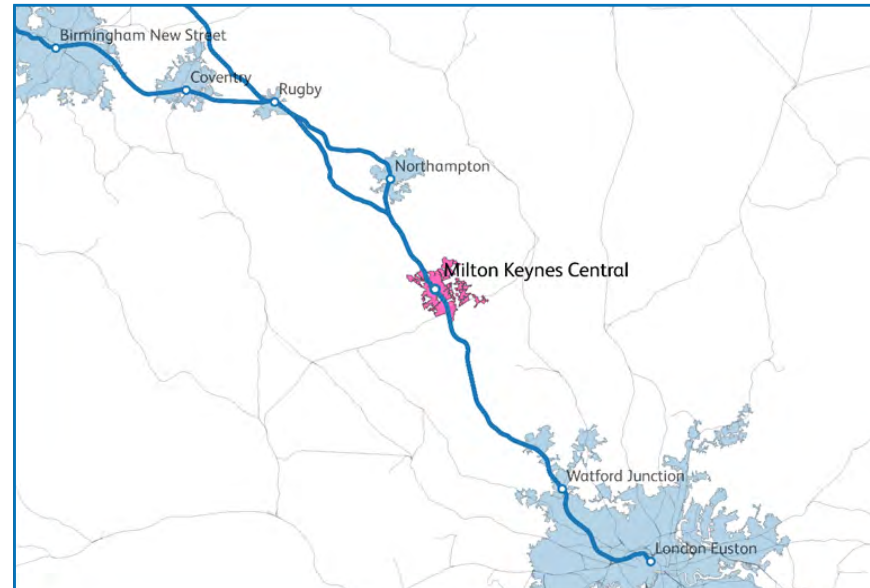

Figure 17: WCSSA Planning Principle B route geography.

to have built an additional 28,000 homes and have generated an additional 32,000 jobs between 2016 and 2031. The Eastern Expansion Area (EEA) provides a further 400-hectare site creating 8,500 new jobs at Magna Park and space for another school and expanded public spaces.³³

Milton Keynes’ rapid rate of growth and development is linked in part to its favourable strategic location, almost equidistant between the West Midlands and London. Access to the wider

rail network is via the West Coast Main Line - which provides potential for direct links to all the major urban centres within the West Coast South study scope – and the Marston Vale branch line, and will from 2024 include connection to Oxford via the planned East West Rail link.

These developments will make Milton Keynes a nationally significant centre at the heart of the highly productive and rapidly growing Oxford-Cambridge ‘arc’ region;³⁴ recognised as a key driver for growth through high-value employment in research, development and technology. The central importance

of this region from a strategic transport perspective has been recognised in the government’s Union Connectivity Review which identifies key ‘growth cities’ (including Milton Keynes) across the arc. England’s Economic Heartland’s transport strategy also emphasises the fundamental importance of integrating Milton Keynes into the region as a key engine for growth.³⁵ While this will be facilitated in part through integration with the planned East West Rail link, it is critical that the connection between the West Coast Main line and the new infrastructure is utilised in such a way that Milton Keynes is connected directly to this wider growth region.

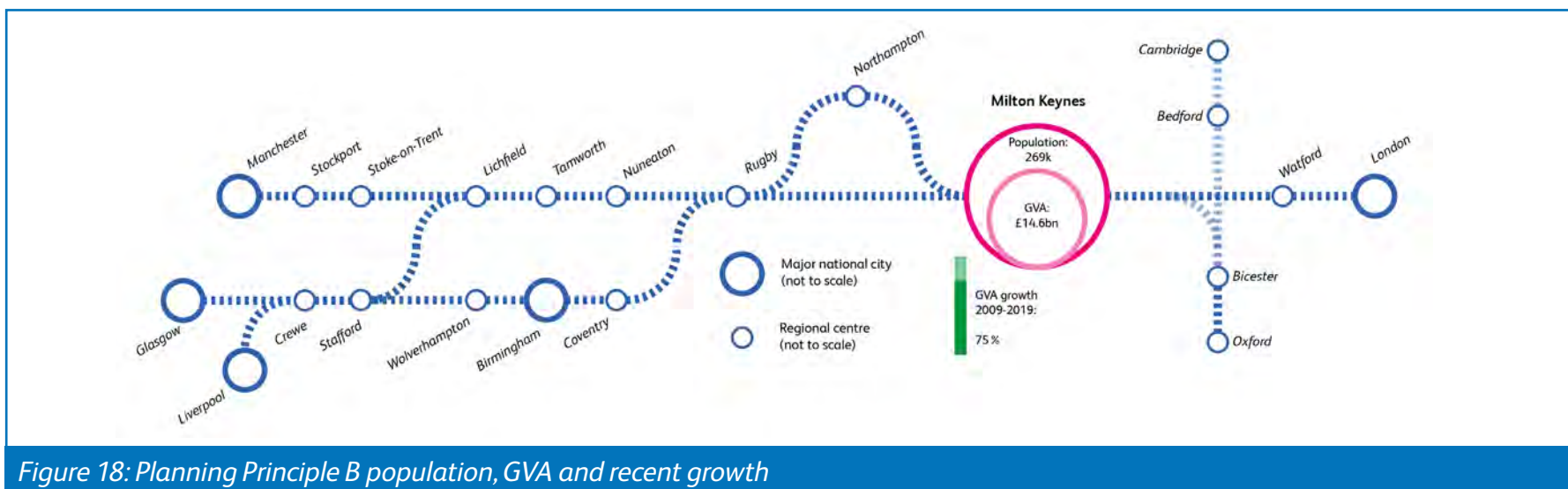

³⁴ Department for Transport (2021) ‘Union Connectivity Review: Final Report’ (available [online](https://assets.publishing.service.gov.uk/government/uploads/system/uploads/attachment_data/file/1036027/union-connectivity-review-final-report.pdf), at: https://assets.publishing.service.gov.uk/government/uploads/system/uploads/attachment_data/file/1036027/union-connectivity-review-final-report.pdf)

³⁵ England’s Economic Heartland (2021) ‘Passenger Rail Study Phase Two’ (available [online](https://eeh-prod-media.s3.amazonaws.com/documents/EEH_Passenger_Rail_Study_Phase_2_Report.pdf), at: https://eeh-prod-media.s3.amazonaws.com/documents/EEH_Passenger_Rail_Study_Phase_2_Report.pdf)

The favourable location and rapid economic growth observed at Milton Keynes is reflected within the results of the economic opportunity analysis, shown in Table 6. There are significant existing revenue flows, in addition to high potential to stimulate modal shift to rail for several flows if connectivity and generalised journey times can be improved.

Crucially, it is anticipated that the East West Rail programme will provide for two direct hourly trains between Oxford and Cambridge, with all other services calling at new high-level platforms at Bletchley. This will impose a sub-optimal arrangement of services on the existing mainline national network by:

- Limiting the headline journey times between Milton Keynes and a range of locations (including Bedford and Cambridge) which will only be accessible through interchange at Bletchley,
- Imposing the need for two changes at both Milton Keynes and Bletchley if intercity-type services continue to call primarily and Milton Keynes Central only,
- Forcing inefficient use of network capacity if all or most passenger services have to call at both Milton Keynes and Bletchley, generating a considerable disbenefit for markets which are served by West Coast South trains.

It is imperative that the significant potential for demographic and economic growth in the Milton Keynes area is supported, and that the sub-optimal rail outcomes outlined above are avoided. This work has aimed to address these issues by pursuing Network

Table 6: WCSSA Planning Principle B priority flows

Origin	Destination	Priority Flows Identified	
		Objective	Priority
Milton Keynes	London	Revenue	High
	Watford	Revenue	High
	Oxford	Mode Shift	High
	Leighton Buzzard	Revenue	Medium
	Coventry	Revenue	Medium
	Rugby	Revenue	Medium
	Birmingham	Revenue	High
		Mode Shift	Medium
	Sandwell	Mode Shift	Medium
	Walsall	Mode Shift	High
	Dudley	Mode Shift	High
	Wolverhampton	Mode Shift	Medium
	Leicester	Mode Shift	High
	Northampton	Revenue	High
		Deprivation	High
	Chester	Revenue	Medium
	Stoke-on-Trent	Revenue	Medium
		Mode Shift	Medium
	Manchester	Revenue	High
	Liverpool	Revenue	Medium
Glasgow	Revenue	Medium	
Edinburgh	Revenue	Medium	

Rail's vision for an East West Main Line in this area through:

- Better integrating Milton Keynes as a growth area into the wider Oxford-Cambridge arc,
- Making use of Milton Keynes' strategic location by exploring direct connections to a greater range of locations using the planned East West Rail infrastructure,
- Providing direct connections from Milton Keynes that do not rely on further change at Bletchley which is a sub-optimal use of the capacity available on the West Coast Main Line.

While the specific train services and calling patterns have varied across scenarios, the principle that Milton Keynes should be provided with a significantly uplifted quantum of passenger service (in support of a range of existing and new markets) has been factored into all scenarios. As such (in addition to providing any relevant service uplifts identified in Planning Principles A-D) the WCSSA study will consider Milton Keynes to be a 'hub' station within all scenarios.

If services calling at Milton Keynes (or any other location) require the infrastructure delivered via the East West Rail programme, or any interventions identified as part of this work, it has been captured as a dependency. As in the Northwest, WCSSA outputs will consider options and requirements within West Coast South route but will not extend the train plan or develop infrastructure options outside the geographic scope.³⁶

³⁶ For the purposes of this work the boundary between West Coast South and the East West Rail route is the connection between the existing Bletchley Flyover and the West Coast Main Line at Denbigh Hall South Junction.

Milton Keynes 'Hub' Definition:

- All passenger services (or with minimal exceptions) planned through Milton Keynes Central will call at the station in all Concept Train Plans,
- Greater integration of Milton Keynes into a wider East West Main Line vision through testing an uplift in passenger service from the planned EWR infrastructure beyond the currently remitted service structure,
- Milton Keynes will be a key focus for development of infrastructure options, prioritising interventions which deliver improved connectivity and remain cognizant of stations capacity issues.

Planning Principle C: Watford, Milton Keynes, Rugby and Coventry

There are several locations on the West Coast South route which are served currently with intercity trains which will not be connected directly by HS2 and will therefore require a comparable level of intercity, or 'limited stop' services post-HS2. This is true at Coventry, Rugby, Milton Keynes and Watford, where conventional services will still be needed to provide intercity connections for important, non-HS2 intermediate markets.

Pre-COVID, Coventry-London flows were served by three limited stop trains per hour between the West Midlands and London, with each of these services calling once at Rugby, Milton Keynes or Watford respectively. This structure was altered in the December 2022 timetable change to provide a direct, non-stop Coventry-London 2tph service, with an hourly train calling at all three of Rugby, Milton Keynes Central and Watford Junction. Coventry, Rugby, Milton Keynes and Watford represent the major urban locations between the West Midlands and London which are served via the West Coast South fast lines. Coventry is the largest urban area within the scope of the WCSSA study which will not be served directly by HS2. It is a major economy with particular importance for the automotive industry, accounting for 10% of all automotive jobs nationally. It is also a significant university city, with over 60,000 students resident. Coventry is also forecast to experience significant population growth of over 89,000 people driving a need for a further 42,400 homes

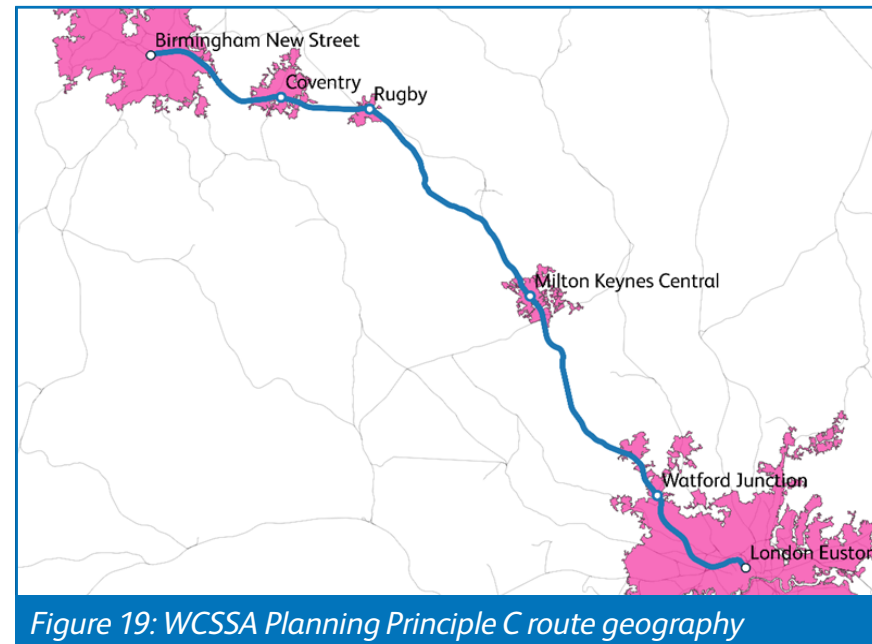

Figure 19: WCSSA Planning Principle C route geography

between 2011 and 2031.³⁷ Rugby is a significant urban area of 76,000 people which is experiencing the fastest rate of economic growth in Warwickshire, at 2.7%. Rugby's wider economy is also diverse, home to a number of high-profile transport businesses including Alstom, Gap, Rolls Royce and GE Power. While GVA per head is lower in Rugby than the wider Warwickshire area, it is clear there is significant potential for growth with a 30% increase in start-up businesses in 2019, and the on-going redevelopment of the Elliott's Field retail park eventually providing over 40,000sqm of floorspace.³⁸

³⁷ Coventry City Council (2017) 'Local Plan' (available [online](https://www.coventry.gov.uk/downloads/file/25899/final_local_plan_december_2017), at: https://www.coventry.gov.uk/downloads/file/25899/final_local_plan_december_2017)

³⁸ Rugby Borough Council (2019) 'Local Plan 2011-2031' (available [online](https://www.rugby.gov.uk/downloads/file/2319/local_plan_2011-31), at: https://www.rugby.gov.uk/downloads/file/2319/local_plan_2011-31)

Watford is a town of 97,000 people which is expected to grow by 14.2% between 2016 and 2035, with plans for an additional 12,000 homes.³⁹ Milton Keynes is already a significant city with a population of 269,000, and a high GVA of £14.6bn.⁴⁰ However, it is Milton Keynes' potential for future growth which marks the need for significant improvement in rail transport provision. This has been captured separately within WCSSA in Planning Principle B.

Gross Value Added is much greater as a proportion of population for Milton Keynes and Watford, both of which have exhibited very strong GVA growth in the ten years from 2009 to 2019. This is symptomatic of proximity to London, and the strong transport links they have with the capital. Watford, Milton Keynes, Rugby and Coventry all represent major urban centres with significant observed and potential for growth, underlining the need to improve rail connectivity beyond only a comparable to December 2022 level.

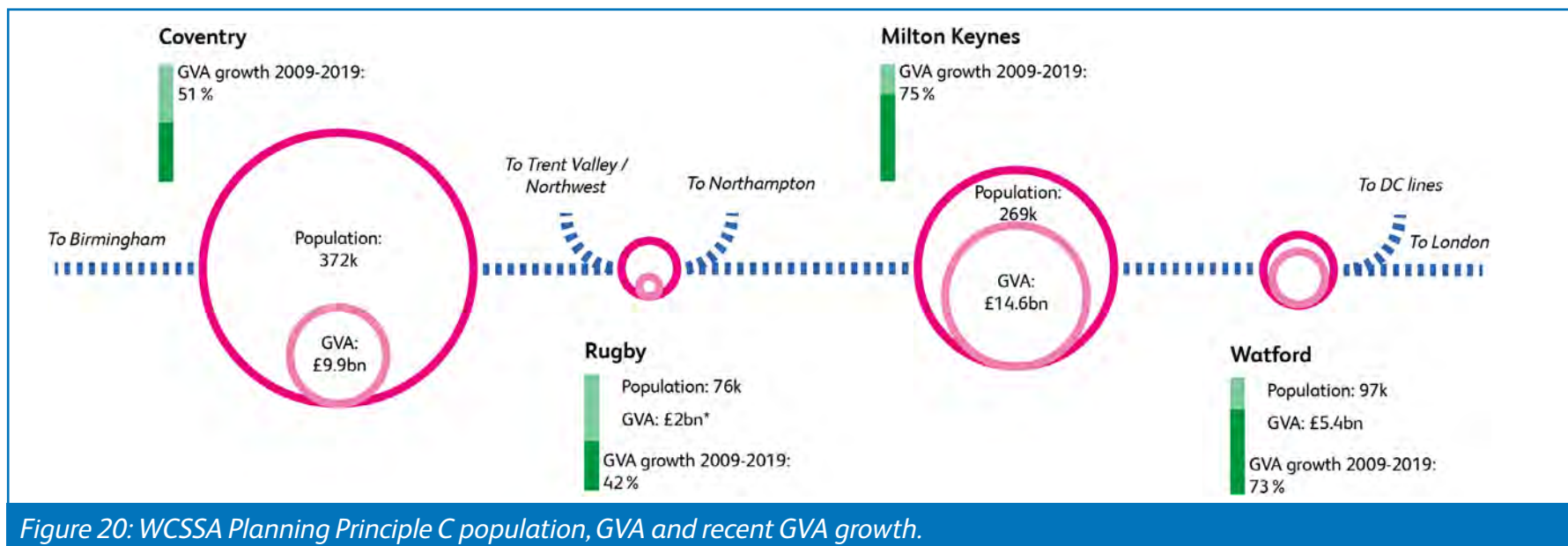

³⁹ Watford Borough Council (2021) 'A Sustainable Town: Final Draft Watford Local Plan 2018-2036' (available [online](https://fd198c31-76ed-460c-8b90-4dac3f151e20.filesusr.com/ugd/b57e7b_ca594d21721a465a98ac331f4acf5b49.pdf), at: https://fd198c31-76ed-460c-8b90-4dac3f151e20.filesusr.com/ugd/b57e7b_ca594d21721a465a98ac331f4acf5b49.pdf)

⁴⁰ Milton Keynes Council (2019) 'Plan:MK 2016-2031' (available [online](https://www.milton-keynes.gov.uk/sites/default/files/2022-05/PlanMK%20Adoption%20Version%20%28March%202019%29.pdf), at: <https://www.milton-keynes.gov.uk/sites/default/files/2022-05/PlanMK%20Adoption%20Version%20%28March%202019%29.pdf>)

The relative importance of these key centres has been shown in the Economic Opportunity Analysis which highlights the significant revenue flows between each of the locations, and from each to Birmingham and London.

Consequently, WCSSA ITSSs have been planned to provide a minimum 2tph limited stop service between all these locations, as shown in Table 7. All Concept train plans have sought to meet this minimum service level and, depending on the specific scenario, have also tested what is required to improve or uplift beyond this where appropriate.

The way in which the above requirements have been captured in scenario ITSSs and concept train plans – i.e. the specific train paths in which these requirements are met – has been determined through the testing process. This has ensured that minimum connectivity is retained while leaving flexibility to test different service structures, including any uplift, from a capacity and economic perspective.

It should also be noted that this quantum of limited stop service represents continuation of the post-December 2022 baseline, or an improvement on it, except for direct service between Coventry and London. Given that Birmingham-London flows will be primarily abstracted to HS2, a minimum London-Coventry service of 2tph is considered acceptable in this context, noting that all passenger-focused scenario ITSSs constructed and tested in this workstream have provided an uplift between Coventry and London beyond this level via different routing options. Scenario requirements and results are provided in section 6 of this report.

Table 7: Planning Principle C minimum passenger service requirements.

Origin	Destination	Baseline tph (limited stop)	Priority Flows Identified	
			Objective	Priority
London	Watford	4tph	Revenue	High
	Milton Keynes	4tph	Revenue	High
	Rugby	2tph	Revenue	High
	Coventry	2tph	Revenue	High
Birmingham	Watford	2tph	Revenue	Medium
	Milton Keynes	2tph	Revenue	High
			Mode Shift	Medium
Rugby	2tph	Revenue	High	
Milton Keynes	Watford	4tph	Revenue	High
	Rugby	2tph	Revenue	Medium
	Coventry	2tph	Revenue	Medium
Coventry	Watford	2tph	Revenue	Medium
	Rugby	4tph	Revenue	Medium
Deprivation			Medium	
Watford	Rugby	2tph	Revenue	Low

Planning Principle D: Macclesfield, Stoke-on-Trent and Milton Keynes

From December 2022, connections between Macclesfield, Stoke-on-Trent and Milton Keynes will be provided by the 2tph intercity service between Manchester and London, with both services stopping at Stoke-on-Trent, and calls at Macclesfield and Rugby in one service, and Nuneaton and Milton Keynes in the other. At Configuration State G, these services are assumed to be released by the introduction of the 3tph HS2 services London-Manchester via Crewe, and the 1tph HS2 service from Handsacre Junction, calling at Stafford, Stoke-on-Trent and terminating at Macclesfield. It is an established industry assumption that a 1tph conventional service will need to be provided between Stoke-on-Trent and Milton Keynes to retain intermediate connectivity as a minimum.

Providing a single hourly call risks underserving a key market between intermediate locations which will not be served by HS2. While Macclesfield is a relatively small urban area, it has a diverse economy, notably home to the headquarters of pharmaceutical manufacturer AstraZeneca. Growth is planned in the town with a need for 950 additional homes from 2010 and proposal to develop a 63-hectare site in the south of the town.⁴¹ Further, the town is also situated to act as a wider rail head for incoming passengers from the East Cheshire region, where access to Crewe is less favourable. Suitable intercity connections

⁴¹ Cheshire East Council (2017) 'Local Plan Strategy 2010-2030' (available [online](https://www.cheshireeast.gov.uk/pdf/planning/local-plan/local-plan-strategy-web-version-1.pdf), at: <https://www.cheshireeast.gov.uk/pdf/planning/local-plan/local-plan-strategy-web-version-1.pdf>)

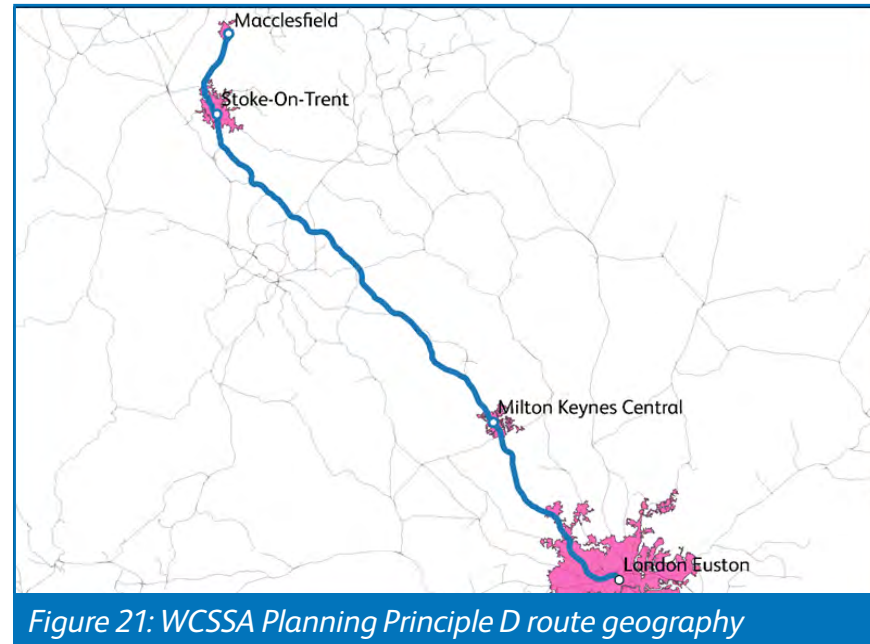

Figure 21: WCSSA Planning Principle D route geography

will be required at Macclesfield to support future growth but also offer a vital link into the wider transport network for the surrounding area.

Stoke-on-Trent is a key urban area on the West Coast network and, after Coventry and Milton Keynes, represents the largest urban area within the WCSSA scope geography. If the neighbouring town of Newcastle-under-Lyme is included, the wider North Staffordshire urban area would be the largest

with approximately 384,000 inhabitants. Stoke-on-Trent has historically suffered from high levels of relative deprivation and has been recognised as a Tier 1 priority within the Government’s levelling up index. This is reflected in a relatively low GVA though it is important to note that there is significant growth, particularly in GVA per capita (at 17.1 % between 2015 and 2018 alone) and in GDP; Stoke-on-Trent was the UK’s 8th fastest growing city in 2020. The city is located between several major urban areas, approximately equidistant between Birmingham and Manchester, and has experienced significant growth in the logistics industry and warehousing.⁴² This is alongside the retention of much of the local ceramics industry and plans for local redevelopment in the city centre at Hanley.⁴³

As noted previously, Milton Keynes is of great future importance on the West Coast Main Line as a major urban centre and a focus for growth; this is detailed further in Planning Principle B above. The importance of this intermediate flow, particularly between Stoke-on-Trent and Milton Keynes / London has been demonstrated in the Economic Opportunity Analysis, shown in table 8. All WCSSA scenario ITSSs have been constructed based on a minimum service provision of 2 limited stop tph between Stoke-on-Trent and Milton Keynes, and at least 2tph between each location and London. This is commensurate with the size of these flows and the potential for growth in this market.

The provision above does not include the planned 1tph from

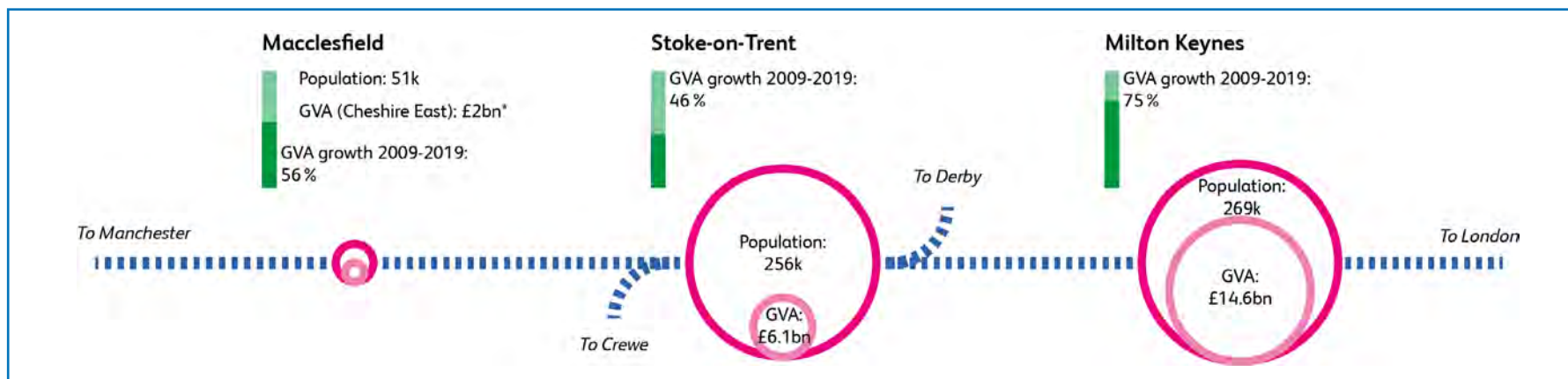

Figure 22: WCSSA Planning Principle D population, GVA and recent GVA growth

⁴² Stoke-on-Trent City Council (2015) ‘Strategic Housing Market Assessment (available [online](https://www.stoke.gov.uk/downloads/file/506/strategic_housing_market_assessment), at: https://www.stoke.gov.uk/downloads/file/506/strategic_housing_market_assessment)

⁴³ The Department for Levelling Up, Housing and Communities’ list of successful first round Levelling Up Fund bidders can be found [online](https://www.gov.uk/government/publications/levelling-up-fund-first-round-successful-bidders), at: <https://www.gov.uk/government/publications/levelling-up-fund-first-round-successful-bidders>

the HS2 network via Handsacre Junction which will provide an additional limited stop train from Macclesfield and Stoke-on-Trent to London. All capacity analysis testing has included the HS2 service in the baseline, though the structure of the train plans has been determined through the testing process in each scenario. Again, the above required train service represents a minimum; uplifts in service beyond this level have been tested to identify trade-offs and requirements dependent on the given scenario focus.

Finally, it is important to recognise that significant markets exist between Milton Keynes, Stoke-on-Trent, Macclesfield and Manchester. No uplift beyond a comparable level of service has been assumed in the Planning Principles as it is likely that additional services will drive known capacity constraints in the Stockport / Manchester areas. The results of the testing for each scenario and the assumed service levels into the Northwest and Manchester are explained in detail in section 6. Where a capacity impact related to the Northwest has been identified it has been recorded specifically in the narrative with any implications for the strategic long-term in the Northwest captured in the recommendations in section 7. This will feed into ongoing work which assesses constraints and enhancement options in the beyond the scope of this study.

Table 8: WCSSA Planning Principle D priority flows and minimum passenger service requirements.

Origin	Destination	Baseline tph (limited stop)	Priority Flows Identified	
			Objective	Priority
London	Macclesfield	2tph	Revenue	High
	Stoke-on-Trent	2tph	Revenue	High
	Milton Keynes	4tph	Revenue	High
Milton Keynes	Stoke-on-Trent	2tph	Revenue	Medium
			Modal Shift	Medium

Planning Principle E: Stafford, Lichfield, Tamworth and Nuneaton

In the 2019 timetable all Trent Valley locations (Stafford, Rugeley, Lichfield, Tamworth, Atherstone and Nuneaton) received the same hourly service which then ran limited stop to London. In the December 2022 timetable Lichfield, Tamworth and Nuneaton gained an additional call in a limited stop service to London from either Manchester or Liverpool. This level of service has been captured in the requirements for all WCSSA scenario ITSSs, but it is recognised by the industry that Trent Valley locations represent an area of future growth in demand and potential for interchange meaning more frequent calls should be prioritised following HS2 introduction.

The urban centres in the Trent Valley, particularly Stafford, Lichfield, Tamworth and Nuneaton, represent significant population clusters. Stafford is a town of around 68,000 people, though the wider borough – incorporating Stone and Eccleshall – numbered 132,488 persons in 2015. Economic activity is high and unemployment is below the national average; the Borough Council have identified the need to provide an additional 113.5 hectares of employment land and 497 residential units by 2031.⁴⁴ Lichfield’s population is approximately 33,000 though the wider borough, incorporating a number of smaller villages, is home to over 102,000. The local economy is characterised by a

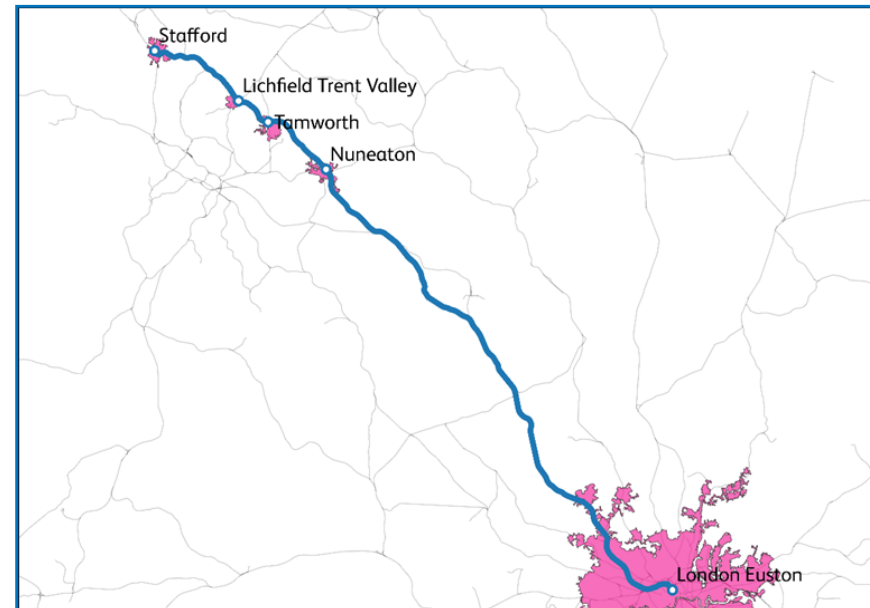

Figure 23: WCSSA Planning Principle E route geography

limited number of high value jobs in the Agriculture sector, while the Hospitality, Arts and Recreation sectors have grown more strongly than the regional average. There is strong demand for housing in the wider district, with a need for an additional 10,030 homes between 2008 and 2029, the majority of which will be delivered in and around Lichfield. The local plan also proposes creation of between 7,300 and 9,000 additional jobs in the area.⁴⁵

⁴⁴ Stafford Borough Council (2014) 'The Plan for Stafford Borough' (available [online](https://www.staffordbc.gov.uk/sites/default/files/cme/DocMan1/Planning%20Policy/Plan%20for%20Stafford%20Borough/PFSB-Adoption.pdf), at: <https://www.staffordbc.gov.uk/sites/default/files/cme/DocMan1/Planning%20Policy/Plan%20for%20Stafford%20Borough/PFSB-Adoption.pdf>)

⁴⁵ Lichfield District Council (2015) 'Local Plan Strategy 2008-2029' (available [online](https://www.lichfielddc.gov.uk/downloads/file/235/local-plan-strategy), at: <https://www.lichfielddc.gov.uk/downloads/file/235/local-plan-strategy>)

Tamworth is also a significant town with a population of over 77,000. GVA growth has been strong in the last ten years, and this economic expansion is set to continue driving the need for an additional 4,425 homes between 2006 and 2031. More than 1,000 of these homes have been built already, demonstrating the latent demand for housing in the area.⁴⁶ Nuneaton is a larger urban area of 90,000 people, rising to around 130,000 if neighbouring Bedworth is included. There is high demand for additional housing resulting from steady economic growth, with notably high ten-year GVA growth. 14,060 new homes

will need to be built between 2006 and 2031 and in addition there is significant investment planned for the town as part of the £7.5bn ‘Transforming Nuneaton’ programme, including the consequent development of the Horiba-MIRA Technology Park.⁴⁷

The relative importance of these Trent Valley settlements – in terms of both population and economy – and the potential for future growth should also be considered considering opportunities for interchange on multiple cross-midlands rail lines including the high-frequency cross city line which

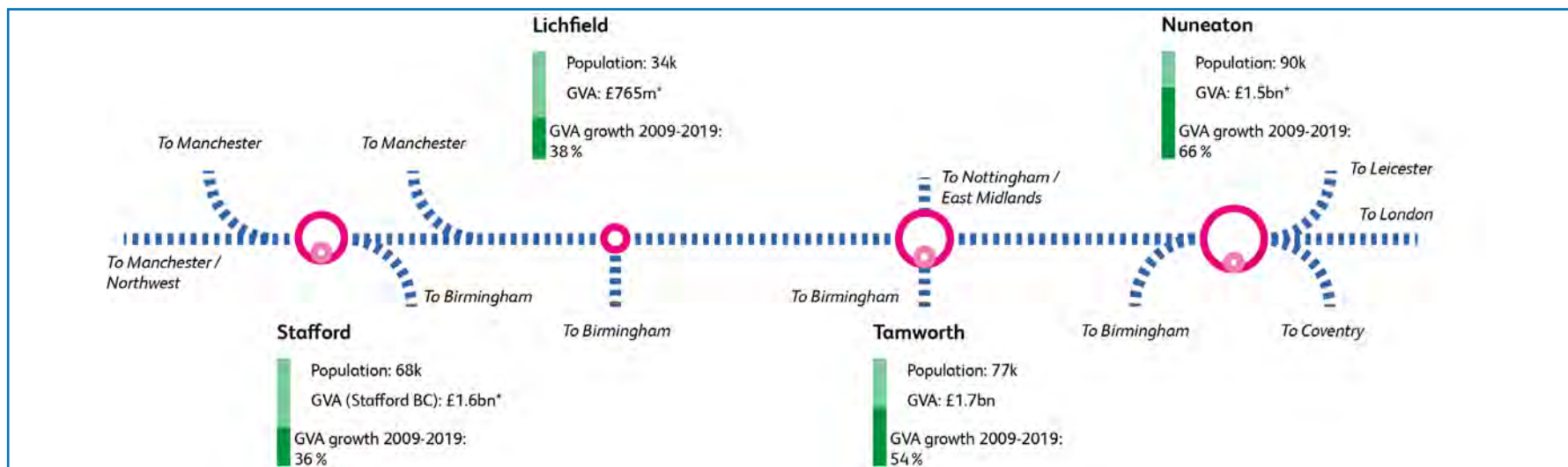

Figure 24: WCSSA Planning Principle E population, GVA and recent GVA growth

⁴⁶ Tamworth Borough Council (2016) ‘Tamworth Borough Council Local Plan 2006-2031’ (available [online](https://www.tamworth.gov.uk/sites/default/files/planning_docs/Local-Plan-2006-2031.pdf), at: https://www.tamworth.gov.uk/sites/default/files/planning_docs/Local-Plan-2006-2031.pdf)

⁴⁷ Nuneaton and Bedworth Borough Council (2019) ‘Nuneaton and Bedworth Borough Council Borough Plan 2011-2031’ (available [online](https://ftps.nuneatonandbedworth.gov.uk/planning/BoroughPlanFINAL12619.pdf), at: <https://ftps.nuneatonandbedworth.gov.uk/planning/BoroughPlanFINAL12619.pdf>)

terminates at Lichfield Trent Valley, as well as the planned uplift in service frequency delivered as part of the in-development Midlands Rail Hub (MRH) programme. This provides additional imperative for improved service provision at Configuration State G, specifically at Tamworth and Nuneaton where additional service from Birmingham to Leicester could be used to improve rail connectivity between locations on the West Coast South route and the East Midlands. Planning Principle E specifies 2tph limited stop services between each major Trent Valley location (Stafford, Lichfield, Tamworth, Nuneaton) and London as the primary target market resulting from the Opportunity Analysis testing.

In addition to the requirement to retain at least 1tph between each Trent Valley location and all the others (per the pre-HS2 network baseline), this represents a minimum uplift commensurate with the significance of these urban settlements as well as the priority flows identified below.

This planning principle is again limited to a target market between the Trent Valley and London though it should be noted that significant New Markets flows have been identified in the economic opportunity analysis between these towns and other locations within the West Coast South geography and in the Northwest. As with all Planning Principles, the requirements outlined above in Table 9 represent a minimum; additional connections to other locations, and uplifted quantum of service, have been tested in the construction of scenario ITSSs in conjunction with the guiding focuses and objectives. Scenario ITSSs and testing results are outlined in section 6 of this report.

Table 9: Planning Principle E minimum passenger service requirements.

Origin	Destination	Baseline tph (limited stop)	Priority Flows Identified	
			Objective	Priority
London	Stafford	2tph	Revenue	High
	Lichfield	2tph	Revenue	High
	Tamworth	2tph	Revenue	High
	Nuneaton	2tph	Revenue	High
All locations (including Rugeley and Atherstone)		1tph	Baseline connectivity.	

Planning Principle F: Shrewsbury and Telford

In the 2022 timetable Shrewsbury and Telford are served by inter-regional services to Birmingham. This forces a change in Birmingham to reach other West Coast South locations, except for two peak trains per day which offer a limited stop service to London. Wolverhampton is served with a regular hourly service to London, along with additional trains in the peaks.

Shrewsbury, Telford and Wolverhampton represent the principle urban areas to the north of the West Midlands which could be provided with additional service directly via the West Coast South at Configuration State G. Shrewsbury is the largest town in Shropshire, with a population of approximately 75,000, and is a focal point for the local economy. In addition to significant administration and distribution sectors, Shrewsbury's location as the primary urban centre in the wider area, including mid-Wales, and its historic significance, mean the local economy is based heavily on retail and the visitor economy. As identified in the Shrewsbury 'Big Town Plan'⁴⁸ and the Shropshire local plan,⁴⁹ the town is a focal point for future growth, with 8,625 new dwellings planned to be built between 2016 and 2038, and around 100 hectares of employment land to be made available located primarily around the existing Battlefield Enterprise Park, and Shrewsbury and Oxon Business Park.

⁴⁸ Shropshire Council & Shrewsbury Town Council (2021) 'Shrewsbury Big Town Plan' (available [online](https://shrewsburybigtownplan.org/wp-content/uploads/2021/01/Shrewsbury-Masterplan-Vision-Jan-2021.pdf), at: <https://shrewsburybigtownplan.org/wp-content/uploads/2021/01/Shrewsbury-Masterplan-Vision-Jan-2021.pdf>)

⁴⁹ Shropshire Council (2020) 'Pre-Submission Draft of the Shropshire Local Plan 2016-2038' (available [online](https://shropshire.gov.uk/media/21100/sd002-draft-shropshire-local-plan.pdf), at: <https://shropshire.gov.uk/media/21100/sd002-draft-shropshire-local-plan.pdf>)

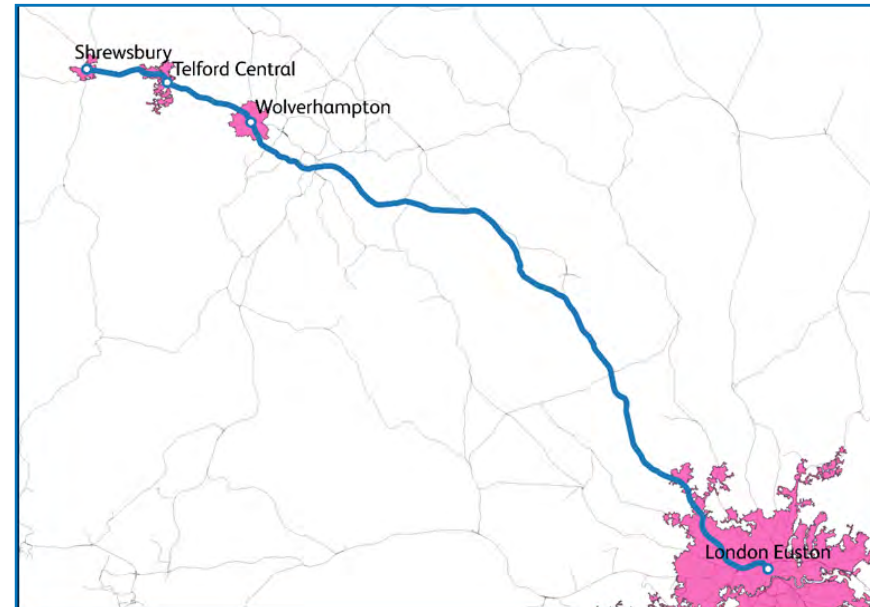

Figure 25: WCSSA Planning Principle F route geography

Telford is a town of over 142,000 and is major urban settlement to the west of Wolverhampton. In 2019 the Gross Value Added for the wider district of Telford and Wrekin was £4.6 billion with the local economy exhibiting strengths in advanced manufacturing, automotive, IT, food and drink; companies such as BAE, Xerox, Heinz, Ricoh and Muller all have sites in the town. The local economy is also set to grow with strategic employment areas

accounting for 76 hectares available for development between 2011 and 2031. The Ministry of Defence is also a key employer with a base at Donnington; this has been identified as the site for the new Defence Fulfilment Centre providing significant additional investment. The requirement for an additional 17,280 new homes by 2031⁵⁰ is consequent on this wider growth in population and employment.

Wolverhampton represents the largest urban area on this corridor. The city is home to 263,000 people, equivalent in size to Stoke-on-Trent, Milton Keynes and Northampton, and is set to grow to 288,000 by 2039. It is in strong central location nationally and is home to leading firms including Jaguar Land Rover, Marston's and

UTC Aerospace. However, Wolverhampton's GVA is low proportionate to its population size, and sluggish economic expansion is reflected in a ten-year GVA growth figure which is the lowest among all the locations of an equivalent size in the WCSSA scope area, and well below the national average. Improving transport links to a wider set of locations on the West Coast Main Line should be considered to improve this picture and support growth; this is a target identified within the active local plan adopted in 2011.⁵¹

The relative size and importance of Shrewsbury, Telford and Wolverhampton is evidenced in the results of the stage one opportunity analysis. As there is not currently a regular limited

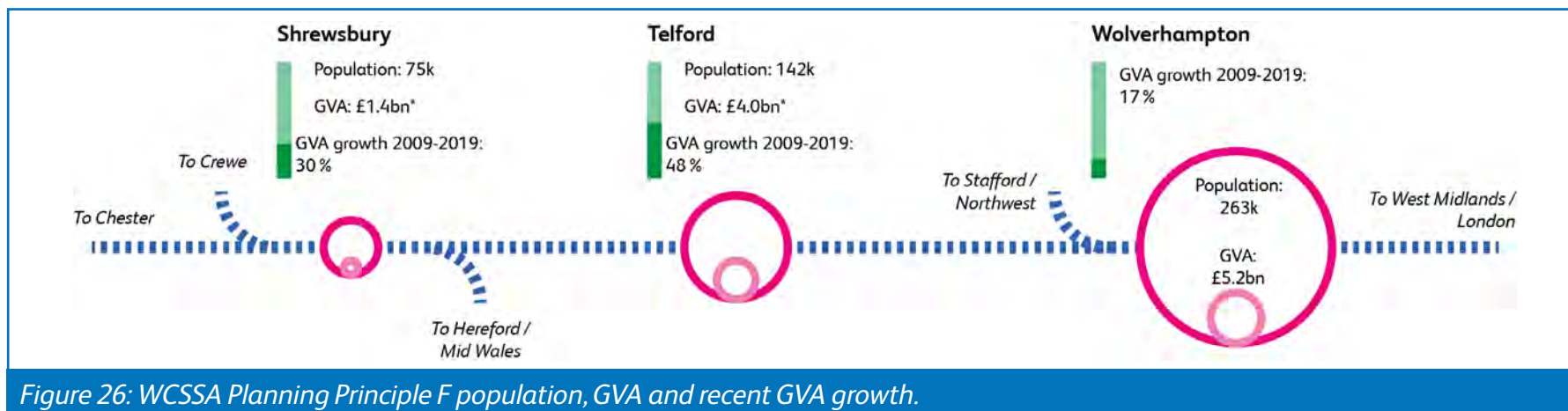

⁵⁰ Telford and Wrekin Council (2018) 'Telford and Wrekin Local Plan 2011-2031' (available [online](https://apps.telford.gov.uk/downloads/localplan/Telford_and_Wrekin_Local_Plan_2011_2031_adopted_Jan_2018.pdf), at: https://apps.telford.gov.uk/downloads/localplan/Telford_and_Wrekin_Local_Plan_2011_2031_adopted_Jan_2018.pdf)

⁵¹ Wolverhampton City Council, Dudley Metropolitan Borough Council, Sandwell Metropolitan Borough Council, and Walsall Borough Council (2011) 'Black Country Core Strategy' (available [online](https://www.wolverhampton.gov.uk/sites/default/files/pdf/Black_Country_Core_Strategy_part_1.pdf), at: https://www.wolverhampton.gov.uk/sites/default/files/pdf/Black_Country_Core_Strategy_part_1.pdf)

stop train to London from either Shrewsbury or Telford, it has not appeared as a significant revenue flow. Instead, Telford and Shrewsbury generate the largest potential flows when tested against the New Markets objective, applying a uniform uplift in GJT to generate figures for Level 1 transport benefits. Taking into account the size of the revenue flow for Wolverhampton to London as an established direct market, the results of the opportunity analysis testing suggest there is a strong case to include a direct limited stop service to Euston from these locations, and uplift the Wolverhampton service, as a minimum.

Table 10: Planning Principle F minimum passenger service requirements.

Origin	Destination	Baseline tph (limited stop)	Priority Flows Identified	
			Objective	Priority
London	Shrewsbury	1tph	New markets	High
	Telford	1tph	New markets	High
	Wolverhampton	2tph	Revenue	High

Planning Principle G: Northampton Service Structure

Northampton is situated on a two-track loop off the fast lines of the West Coast Main Line between Hanslope and Hillmorton Junctions. In the pre-COVID timetable it was served with 3

trains per hour from London Euston to Birmingham New Street. From December 2022 this structure has been altered, reducing the service between Northampton and Birmingham to a 2tph stopping service, with a third London-Northampton service provided in addition.

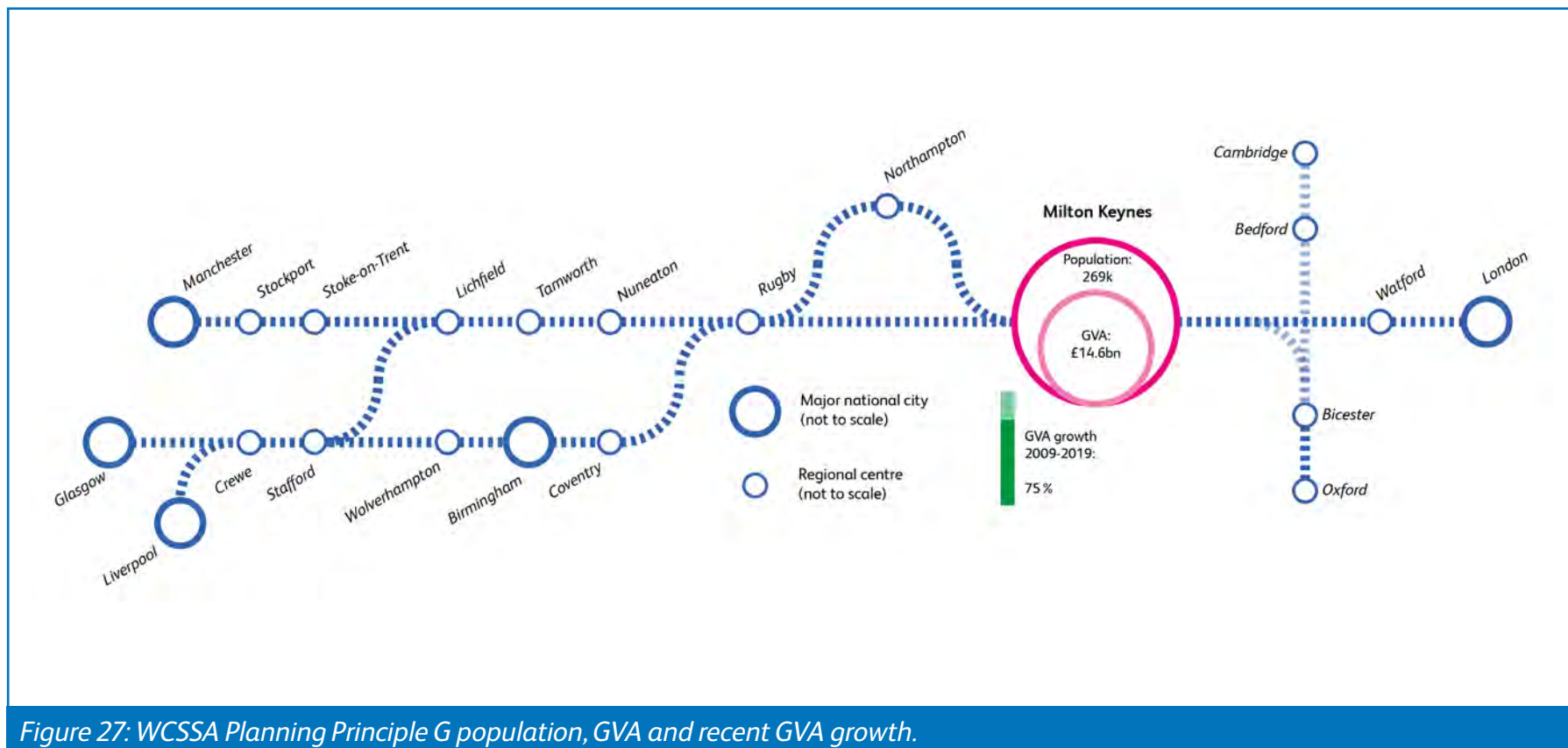

Figure 27: WCSSA Planning Principle G population, GVA and recent GVA growth.

Northampton is a significant urban area within the geographic scope for WCSSA. The town’s population in 2021 was 225,000 which is comparable with the largest urban areas not directly served by HS2 on the West Coast South route. The local economy contributes around £6bn Gross Value Added, though ten-year growth is noticeably lower compared to locations like Watford, Milton Keynes and Coventry. The Northampton Waterside Enterprise Zone is located near the University of Northampton and hosts companies such as Cosworth, Mahle Powertrain and GE Precision Engineering. Northampton’s economy is set to grow with a significant contribution from the high-performance motorsport and technology sector, contributing to the need for an additional 18,870 homes to be built within Northampton Borough between 2011 and 2029.⁵²

The relative size and importance of Northampton is reflected in the results of the economic opportunity analysis. While a range of flows have been identified across each objective, the most significant are those from Northampton to London, Milton Keynes and Birmingham. The minimum required service provision this will drive in all WCSSA scenario ITSSs is shown in Table 11.

The 2tph Northampton-London is a limited stop requirement and is additional to the need to maintain connectivity between Northampton and suburban locations on the Euston corridor. This minimum provision is considered broadly reflective of both the relative importance of Northampton as a settlement,

⁵² West Northamptonshire Joint Planning Unit (2014) ‘West Northamptonshire Joint Core Strategy Local Plan (part 1)’

Table 11: Planning Principle G minimum passenger service requirements.

Origin	Destination	Baseline tph (limited stop)	Priority Flows Identified	
			Objective	Priority
Northampton	London	2tph	Revenue	High
	Milton Keynes	4tph	Revenue	High
			Deprivation	High
	Birmingham	2tph	Revenue	High

and in response to the highest priority flows identified in the opportunity analysis. Uplift beyond this level, to a variety of locations, has been explored throughout the scenario testing with different routing options for passenger services considered, including extensions of East West Rail services.

Northampton also occupies a particularly constrained part of the West Coast South route. As outlined in the assumptions section of this report previously; no Intercity West Coast trains can be ‘transferred’ directly from the slow lines via Northampton to the high-speed network and so the capacity released by HS2 in this area is confined solely to the fast lines. The slow lines via Northampton also provide network access for Daventry International Rail Freight Terminal (DIRFT) and the under-construction Northampton Gateway Strategic Rail Freight Interchange. Uplift in freight as well as uplift in passenger



service to Northampton has been tested as part of WCSSA work reflective of the area's significance and needs. Options to mitigate capacity constraints are accordingly outlined in the testing and recommendations.

The pre-HS2 network baseline train service structure at Northampton includes through running passenger services that serve suburban locations between Euston and Milton Keynes, and between Coventry and Birmingham. WCSSA adopts a position that there is likely to be a range of efficiencies in splitting these service groups which, in effect, serve different local markets. Planning Principle G determines that all WCSSA outputs aim to provide the service provision outlined in Table 11 as a minimum as well as reserving the right to sever direct connectivity between local stations on the Coventry Corridor with locations south of Northampton on the grounds of realising wider operational efficiencies and maximising network capability.

Northampton has also been an area of focus for infrastructure optioneering throughout this work in recognition of the potential constraints that exist on this part of the network pre and post-HS2. The recommendations outlined in section 7 for both utilisation of released capacity and development of infrastructure enhancements are made accounting for the rail needs outlined above, as well as wider implications for the future operator map and rolling stock.

Northampton Service Group Separation:

It is recognised that the Northampton area will not directly benefit from the capacity released by HS2 and that all options to relieve this constraint should be considered.

WCSSA adopts the position that service groups which operate between London and Birmingham via Northampton in the pre-HS2 network baseline can be severed at Northampton to:

1. Provide more flexibility in train planning on the slow lines via Northampton,
2. Maximise the opportunity to incorporate uplifted levels of freight to strategic sites on the slow lines,
3. Rationalise future diagrams and fleet structures for local West Midlands and 'Euston Corridor' services which do not need to be tied together,
4. Provide for flexibility in serving new rail connections to the East Midlands from the slow lines which may have a credible strategic case.

Baseline connectivity for Northampton and Long Buckby will be retained in all ITSSs, however service group separation may result in:

- Loss of direct connectivity between local stations on the Coventry Corridor and locations to the south of Northampton.

To mitigate against this disbenefit WCSSA stage two ITSSs will be planned on the basis of improving the GJT between locations which lose direct connectivity, through improved options for interchange with limited stop services at Rugby, Coventry or Birmingham International.

Through linkage could be retained in future, after further development, though it is recommended that the relative benefits of service group separation in this area are fully capture in post-HS2 changes to the conventional train service.

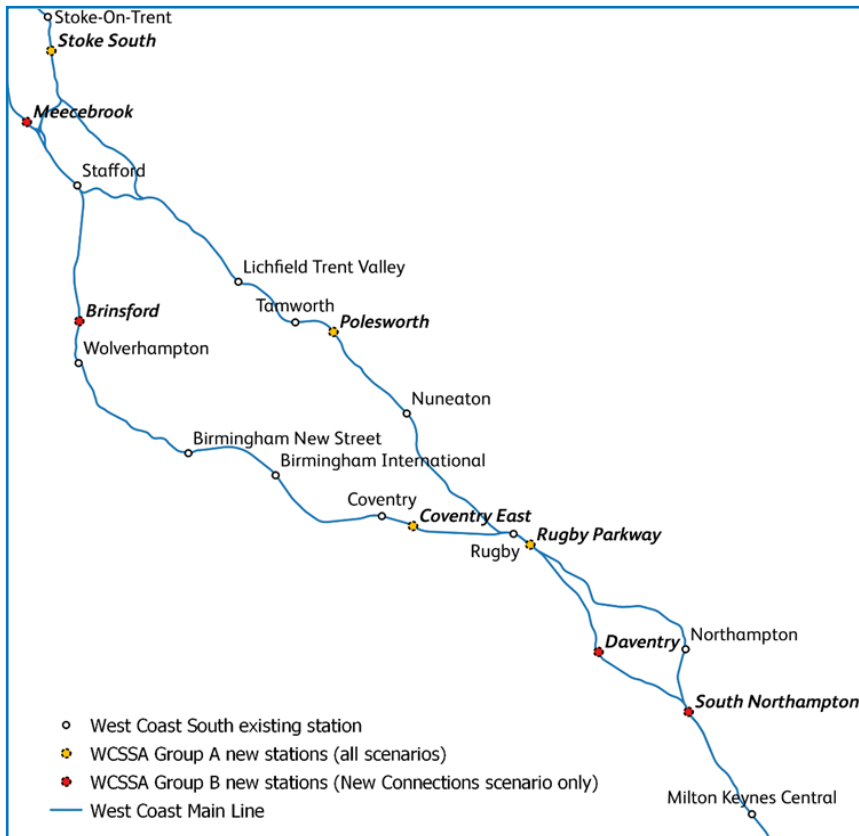

Figure 28: WCSSA new stations included in the scenario testing.

Planning Principle H: New Stations

The capacity released by HS2 could be used to serve entirely new stations. While it is recognised that part of the case for constructing the new high-speed infrastructure is to release conventional network capacity to better connect communities to the rail network, providing calls at new stations requires slowing train services down and therefore imports an impact on wider network capacity. Construction and service of new stations may generate a benefit in one part of the network, but could generate a significant disbenefit in another by reducing total available capacity to improve frequency or reduce journey times at existing stations.

The WCSSA study has evaluated these trade-offs by testing a series of new stations proposals together and assessing the corresponding impact on the whole train service. Eight new stations proposals have been sifted into two groups. The four Group A new stations are included in all train service scenarios tested in this work, ensuring that some of the capacity released by HS2 is reserved to serve new stations and distribute the benefits of HS2 to currently underserved or unconnected communities:

<p>Rugby Parkway</p>	<p>Proposal promoted by Warwickshire Country Council currently at early development stage. Strategic case predicated on supporting significant local housing development and abstracting passengers currently driving into the existing Rugby station. Proposed location is on the slow lines, east of Hillmorton Junction.</p>
<p>Coventry East</p>	<p>Potential new station sited in the Binley/Willenhall area of Coventry. Opportunity to support local transport connectivity as well as provide parkway connection with the A46. Currently being assessed by the industry.</p> <p>New station could also provide turnback capability for local West Midlands services providing a significant operational benefit.</p>
<p>Polesworth</p>	<p>Aspiration to either upgrade and routinely serve existing Polesworth station or relocate in the local area to better connect to the road network. New station unlikely to generate a significant operational or capacity impact on the four-track Trent Valley lines.</p>
<p>Stoke South</p>	<p>Aspiration to reopen former Trentham station to the south of Stoke-on-Trent. Local area is densely populated, offering a favourable rail market and the potential to relieve local transport infrastructure.</p>

The new stations identified above have been included in all scenario ITSSs for one or more of the following reasons:

- The maturity of existing development work for a given proposal,
- The extent to which a new station demonstrates a strong strategic rationale using the capacity released by HS2,
- The proposal is unlikely to have a significant capacity or capability impact given its location on the network.

The four Group B stations are a secondary priority and have only been included in the New Connections scenario ITSS:

South Northampton	Network Rail is aware of a series of long-standing aspirations to introduce a station on the slow lines between Hanslope Junction and Northampton. Potential strategic case to offer a parkway to relieve existing Northampton station and encourage wider modal shift in the Northamptonshire area.
Daventry	Daventry has been identified as a major population cluster which is not connected directly to the rail network. A fast line station could provide improved rail connectivity for the town as well a parkway interchange near the A5, A45 and M1.
Brinsford	Local station aspiration between Wolverhampton and Penkridge. Strategic rationale is based on supporting local growth as well as proximity to A449 and M54.
Meecebrook	Local station aspiration supporting the development of ten thousand homes as part of the Meecebrook garden village in Staffordshire.

These proposals are much less mature than those in Group A or are known to pose a significant operational challenge given their assumed locations. As such they have been tested separately as part of the New Connections scenario which also includes uplift in the service provision at Group A stations and intercity-type services at Coventry East and at Rugby Parkway on the fast lines (supporting the specific strategic rationale to stimulate modal shift for these parkway proposals).

Adopting this grouped approach means that the wider, whole-system impact of serving a range of new stations can be assessed, and a basic understanding of what is required from the wider network to prioritise new stations can be defined. The results clarify the long-term strategic fit for new stations proposals by demonstrating the extent to which each group drives a trade-off in the train service or exacerbates capacity constraints on the wider network. Recommendations related to network capability to support new stations proposals are accordingly captured in section 6 of this report.

A minimum service of 2tph has been planned at the relevant timing point for each new station within the concept train plans. This means that the required trains could call at these stations on a given line of route, compliant to the timetable planning rules, but no specific detail on locations, development or catchment areas has been determined. For example, the assumed new station at South Northampton could be positioned anywhere between Hanslope Junction and Northampton, while the new station at Daventry could be sited anywhere between Hanslope Junction and Rugby on the fast lines. The wider impact of calling services at these stations is identified, but no recommendation is made on exact infrastructure requirements.

No new stations proposals have been included in this work south of Milton Keynes. This is on the grounds that both fast and slow line capacity on the Euston corridor is likely to remain significantly constrained in future, though there may be potential for some limited slow line calls at the currently

unserved Queens Park station or Willesden Junction should a case be made for reinstatement of slow line platforms.

Accordingly, WCSSA has not evaluated the benefits accrued by new stations in generating more trips and revenue, encouraging modal shift, or stimulating local economic growth. Calls at new stations have been included in the appropriate service groups for each, agreed and endorsed by the wider industry through the WCSSA working group demonstrating the wider network impact and extent to which identified proposals demonstrate strategic fit over the post-HS2 long-term.

The development of specific new stations proposals should be undertaken on a case-by-case basis per the established business case process, in line with the recommendations made in this report in section 7. Any new stations proposals on West Coast South route which have not been included in either Group A or Group B – including any in located between London and Milton Keynes - should refer to this document as a long-term direction of travel for the wider train service, and should engage with Network Rail to assess the potential impacts and case for investment. Necessarily, accommodation of each proposal within a given Concept train plan only provides assessment of strategic fit for the post-HS2 period. This does not provide any assessment of accommodating new stations within the pre-HS2 network baseline timetable which, due to the existence of a high quantum of Intercity West Coast services, could be prohibitive and requires separate development work.

Analysis and Results



Each scenario in WCSSA is based on an overarching Indicative Train Service Specification (ITSS) which captures a set of minimum freight and passenger service requirements (outlined in the previous Planning Principles section), and a set of scenario-specific requirements which are reflective of that scenario's driving objective(s) and focus.

Each scenario ITSS has then been tested from a rail capacity perspective to understand what can be accommodated on the post-HS2 conventional network, and what is required to include services or calls which cannot be accommodated on the existing infrastructure. Both the no-infrastructure, released capacity and with-infrastructure concept train plans have then been assessed against the study objectives (outline in section 2) as part of an economic multi criteria assessment. The results of this analysis give a comparative assessment on how each concept train plan contributes toward the guiding objectives in any given scenario, and how different scenarios compare against each other. The following subsections step through each scenario in sequence, presenting:

- a. The rationale, focus and requirements for that scenario and the scenario Base ITSS which captures them,
- b. The released capacity concept train plan which demonstrates the capability of the existing conventional network infrastructure to accommodate the Base ITSS post-HS2,

- c. Emergent constraints which limited the ability to plan all services in the Base ITSS,
- d. The with infrastructure concept train plan and the infrastructure options which were required to plan in priority services which could not be accommodated otherwise.

A holistic cross-scenario assessment based on the collected results of all the scenario testing is provided in section 6. The assessment is used as a basis for a prioritised set of infrastructure options for further development and funding.

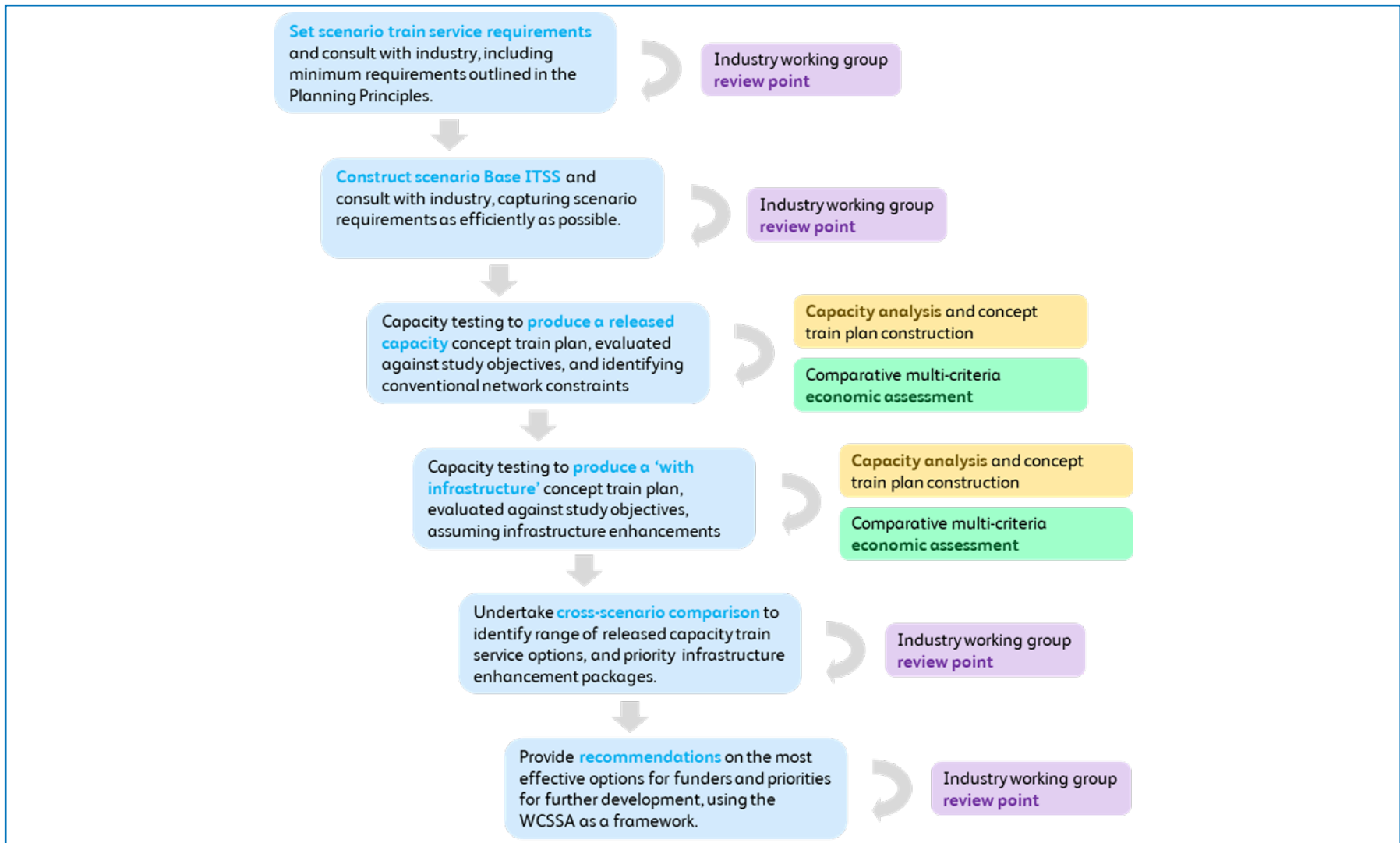

Figure 29: WCSSA scenario testing process

Scenario One: Freight Focus

Scenario Focus

Meeting high growth forecasts for freight and expanding routing options.

Testing Purpose

Assess the capability of the conventional infrastructure to accommodate high growth for freight utilising the capacity released by HS2.

Determine priorities for further investment to unlock benefits for freight in a high growth scenario or exceeding high growth forecasts.

ITSS Guiding Objective

Supporting an MDST Scenario B 'High Growth' hourly freight train service and maximising marginal external costs associated with mode-shift from road to rail (for Heavy Goods Vehicles).

Train Service Priorities

Prioritisation of freight services in concept train planning, and protection of capacity to utilise new or underused routes for freight

Rationale

The first scenario tested as part of the WCSSA study focused on the quantum and routing options for freight paths. The rationale was to explore what impacts on the train service and infrastructure prioritising freight services will have, given the strength of forecasted freight growth and the potential for freight uplift to become a focus for wider government policy in future.

The driving objective in this scenario was to achieve a provision for rail freight on West Coast South consistent with the MDST Scenario B 'high growth' forecast, or beyond. The assessment method used to track the success in delivering this objective – quantifying Marginal External Costs in transferring freight movements from road to rail – does not fully capture the wider benefits associated with rail freight and was used for comparative purposes only. The whole-system benefits of accommodating a freight focus ITSS would be much greater, including:

- Cost savings for customers enabled by faster maximum speeds and timetable efficiencies compared to road transit,
- Time savings for customers due to more direct routing and avoidance of road congestion,
- Improved reliability given the greater certainty around average journey times on key freight routes,

⁵³ See Planning Principle A for more information on the benefits of uplifted freight capacity and routing informing this study.

- Congestion relief for roads through modal shift at specific points of high utilisation on the road network,
- Environmental benefits linked to reduced carbon emissions, improving air quality and noise levels,
- Better safety compared to other modes of transport notably use of Heavy Goods Vehicles.

The train planning outputs presented in this section demonstrate the trade-offs and infrastructure interventions required to accrue freight benefits. Should a focus on uplifting capacity for freight over the long-term become a driving policy objective for the government or the industry the outputs of this scenario give an indication of where investment may need to be made in the conventional network on West Coast South route beyond introduction of HS2 services.

Freight Focus: Scenario-Specific Requirements and Base ITSS

As with all scenarios tested in this work, the requirements outlined in the planning principles have been incorporated in the base ITSS for this scenario as a minimum. As this is a freight focused scenario, no additional scenario-specific passenger requirements were set. Instead, the high growth freight provision outlined in Planning Principle A was prioritised, comprised of the freight services outlined in table 12.

Table 12: Freight services prioritised in the Freight Focus scenario drawn from the MDST High Growth forecast.

Type	tph	Origin	Destination
Class 1	2	London (via Willesden Jn.)	Birmingham or Crewe
Class 4	2	London (via Camden Jn.)	Birmingham or Crewe
Class 4	1	East West Rail	Crewe
Class 4	1	Nuneaton (from E. Mids)	Crewe
Class 4	1	Nuneaton (frow South)	Crewe
Class 4	1	West Midlands	Crewe
Class 6	1	London	Birmingham or Crewe
Class 6	1	Nuneaton (from E. Mids)	Crewe
Class 6	1	West Midlands	Crewe

In addition to the above, the scenario-specific freight paths outlined below in table 13 were also included in the base Freight Focus ITSS. These services have not been included in any of the other passenger-focused scenario ITSSs:

Table 13: Scenario-specific freight services included in the Freight Focus base ITSS only.

Type	tph	Origin	Destination
Class 1	1	Daventry	Crewe
Class 4	1	East West Rail	Crewe
Class 4	1	EW.Midlands (via Cannock)	Crewe

These additional paths constitute a ‘freight max’ provision based on expert input from the freight sector. They are aimed at capturing paths in service of long-term growth markets. This includes a provision of Class 1 freight that is beyond the high growth forecasts on the grounds that express logistics represents a significant potential growth market. Additional Class 4 paths – again, beyond a high growth level - via East West Rail and Cannock are also provided given the potential for development of intermodal distribution centres on both those axes, as well as the opportunity to use East West Rail as a major national freight route with investment in the F2MN scheme between Felixstowe, Ely and Cambridge. The additional paths provided via East West Rail could be planned toward either Oxford or Cambridge, depending on both market requirements and the availability of capacity at either end of the East West route.

The base ITSS for the Freight Focus scenario is shown in figure 31, including both the freight and passenger services required to meet the scenario objectives aspired to in full. The base ITSS can also be found in table form with additional information in Appendix C.

The base ITSS represents an aspirational level of service. Not all paths could be accommodated on the existing infrastructure, and trade-offs were required based on the priority focus of the scenario. These are highlighted in the following sub-sections.



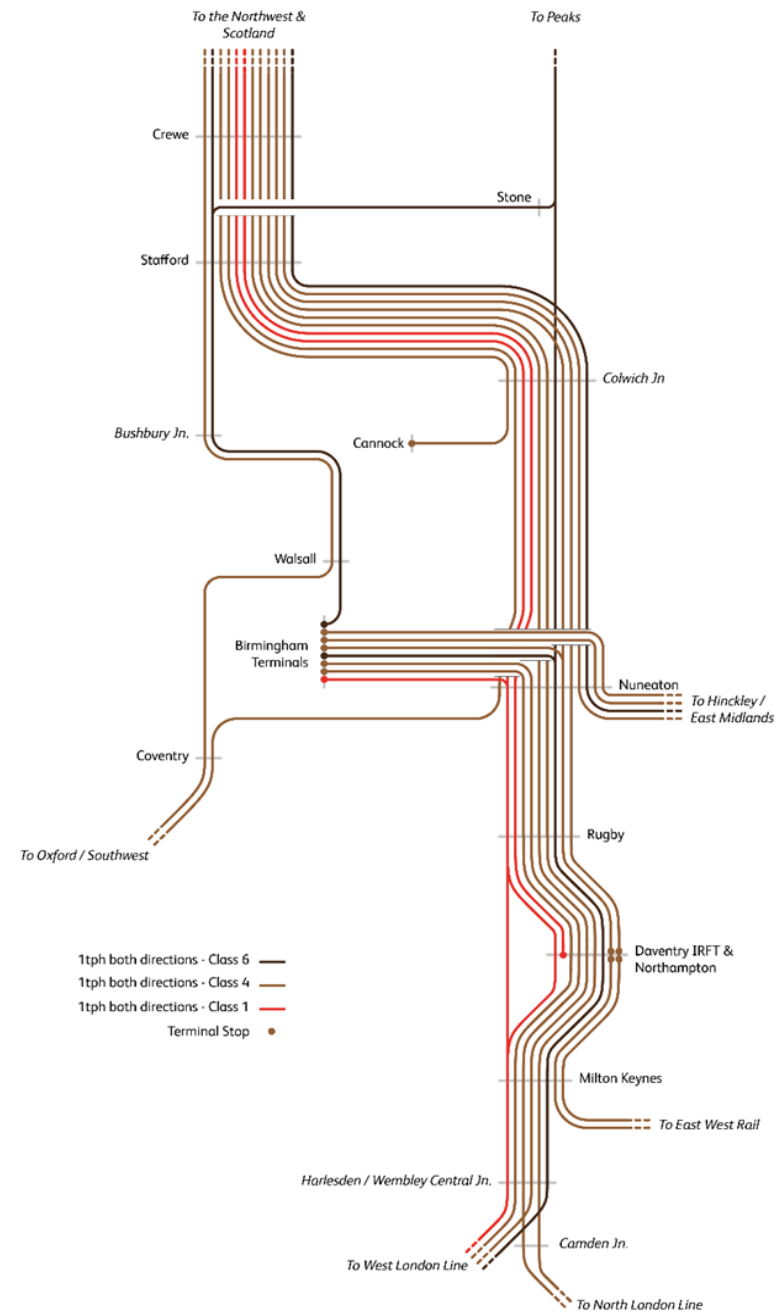
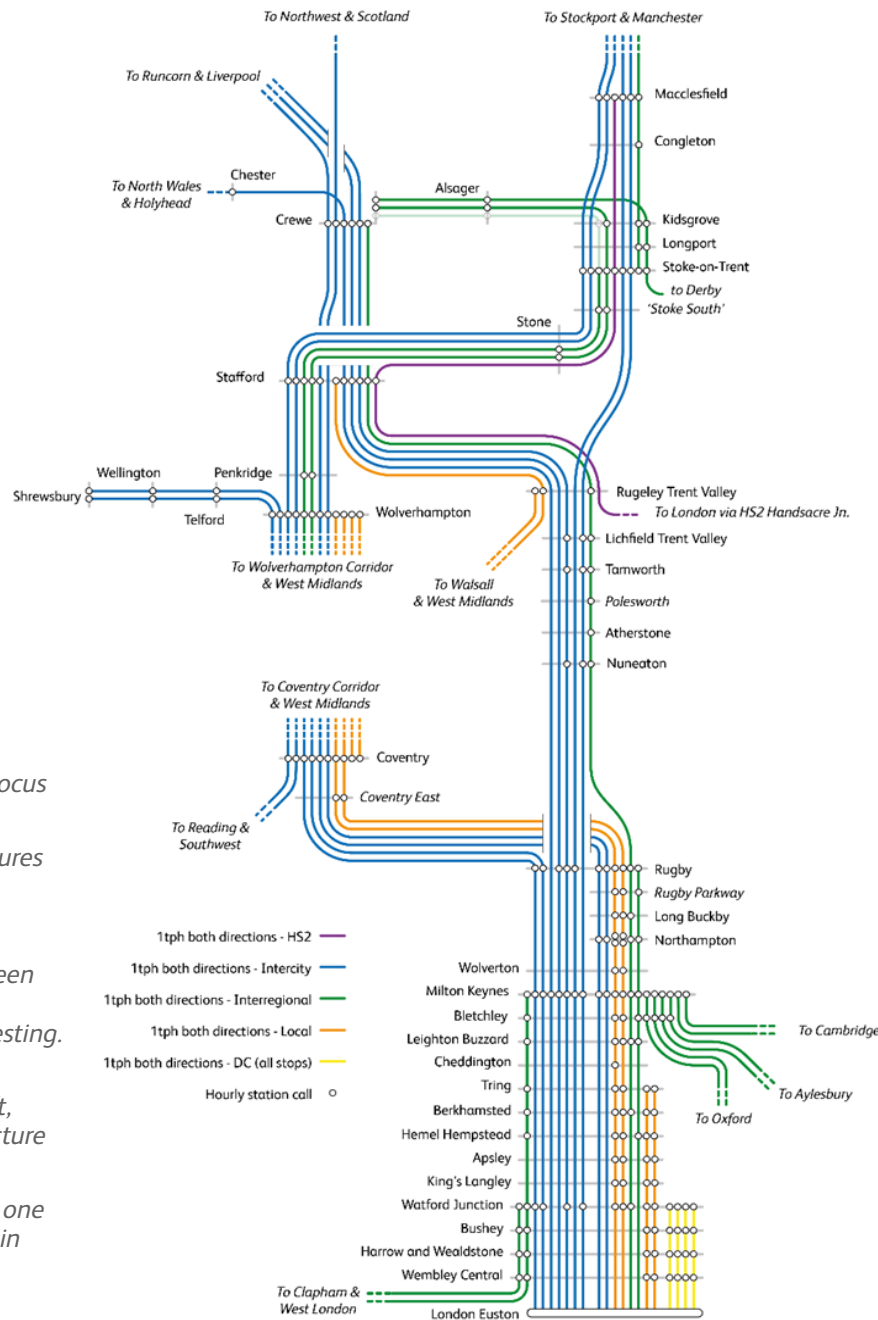

Freight Focus: Released Capacity Concept Train Plan

The first round of capacity analysis was used to create the concept train plan shown below in figure 32 below. This could be planned compliantly using existing conventional infrastructure and only the capacity released by HS2.

The results of the multi-criteria assessment analysis evidence the potential to provide improved passenger connectivity alongside a high growth provision for freight as shown in table 14. This could be achieved by providing capacity for uplifted freight via the trunk West Coast South route from London (4tph Class 4 and 1tph Class 1), but also through a significant quantum of freight on to the West Coast Main Line via East West Rail (1tph Class 4) and Nuneaton (2tph Class 4 and 1tph Class 6).









However, trade-offs from the base ITSS were required. Two intercity passenger paths London-Birmingham via Northampton, as well as one intercity path London-Crewe/Liverpool, could not be compliantly planned. This was primarily driven by the need to provide sufficient slow line capacity for freight services, and the consequent pressure to accommodate a range of passenger service types on the fast lines.

Further, while a High Growth forecast level of freight was achievable not all the 'freight max' paths could be accommodated. It was not possible to accommodate all required Class 4 and Class 6 paths from London alongside a viable passenger service over a standard hour. For the purposes of the

assessment, the Class 6 path was removed from the final train plan. Further work should be undertaken to explore the potential to segregate freight service types by time of operation or by route, focusing West Coast South for primarily intermodal, Class 4 flows if possible.

The limitations on capacity between London and Milton Keynes were overcome in this scenario by planning additional freight via the East West Rail route. This demonstrates the extent to which the capacity released by HS2 will most effectively be used for freight through utilisation of alternative routings. Constraints encountered between Rugby and Nuneaton meant the second Class 4 path via East West Rail could not be planned compliantly and consequently does not feature in the released capacity concept train plan. It was however, prioritised in the 'with infrastructure' testing.

Table 14: Freight Focus released capacity train service economic multi-criteria assessment results showing change from the released capacity economic baseline.

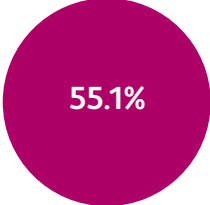
Objective	Multi-Criteria Assessment Measure	(% Change from post-HS2 economic baseline)
	<p>Maximise Revenue Total forecasted revenue generated from passenger abstractions.</p>	
	<p>Supporting Development Forecasted value of time (VoT) benefits weighted for relative deprivation for each corresponding origin and destinations.</p>	
	<p>Encourage Modal Shift Total passenger miles abstracted from road to rail.</p>	
	<p>Stimulate New Markets Total value of time benefits for flows classified as new markets, either not directly connected or not frequently served.</p>	
	<p>Support Freight Growth Total freight marginal external costs (MEC) benefits measured by the emissions reduced through modal shift from road to rail.</p>	

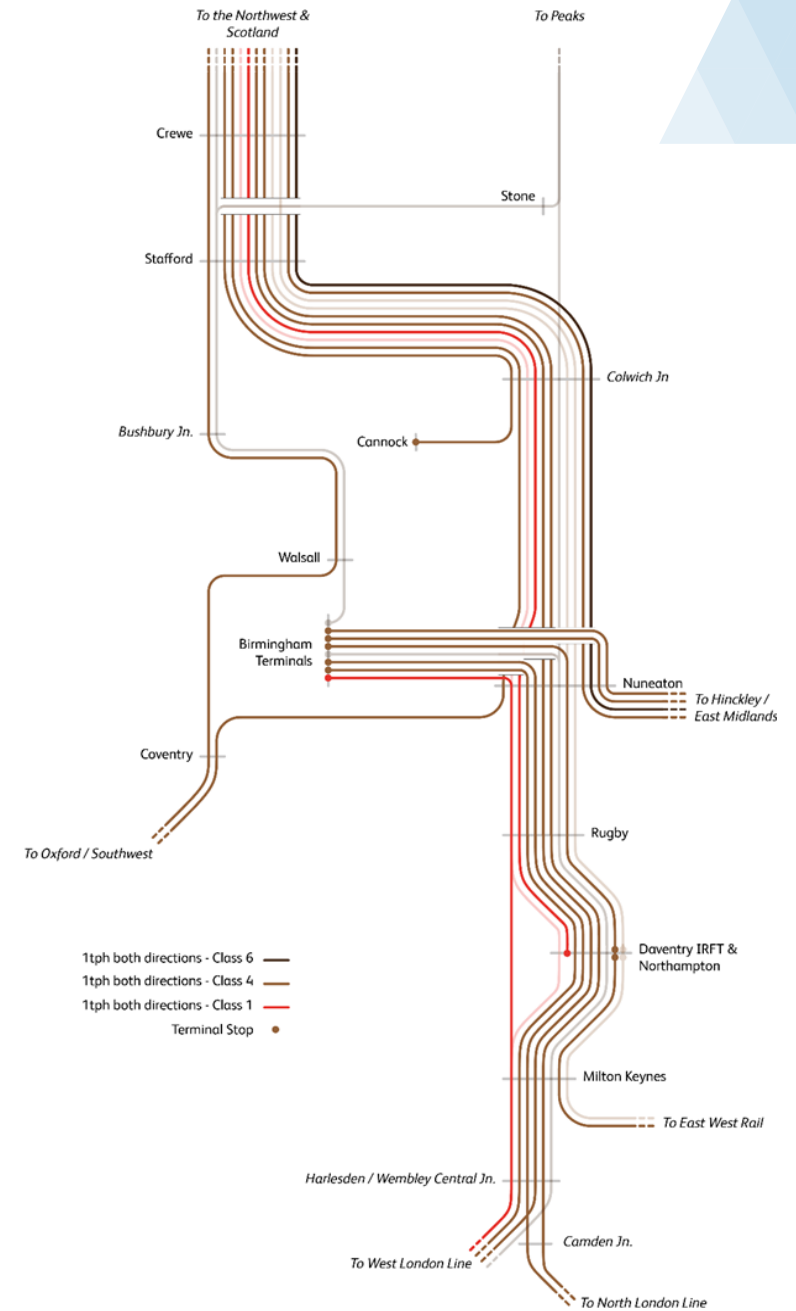
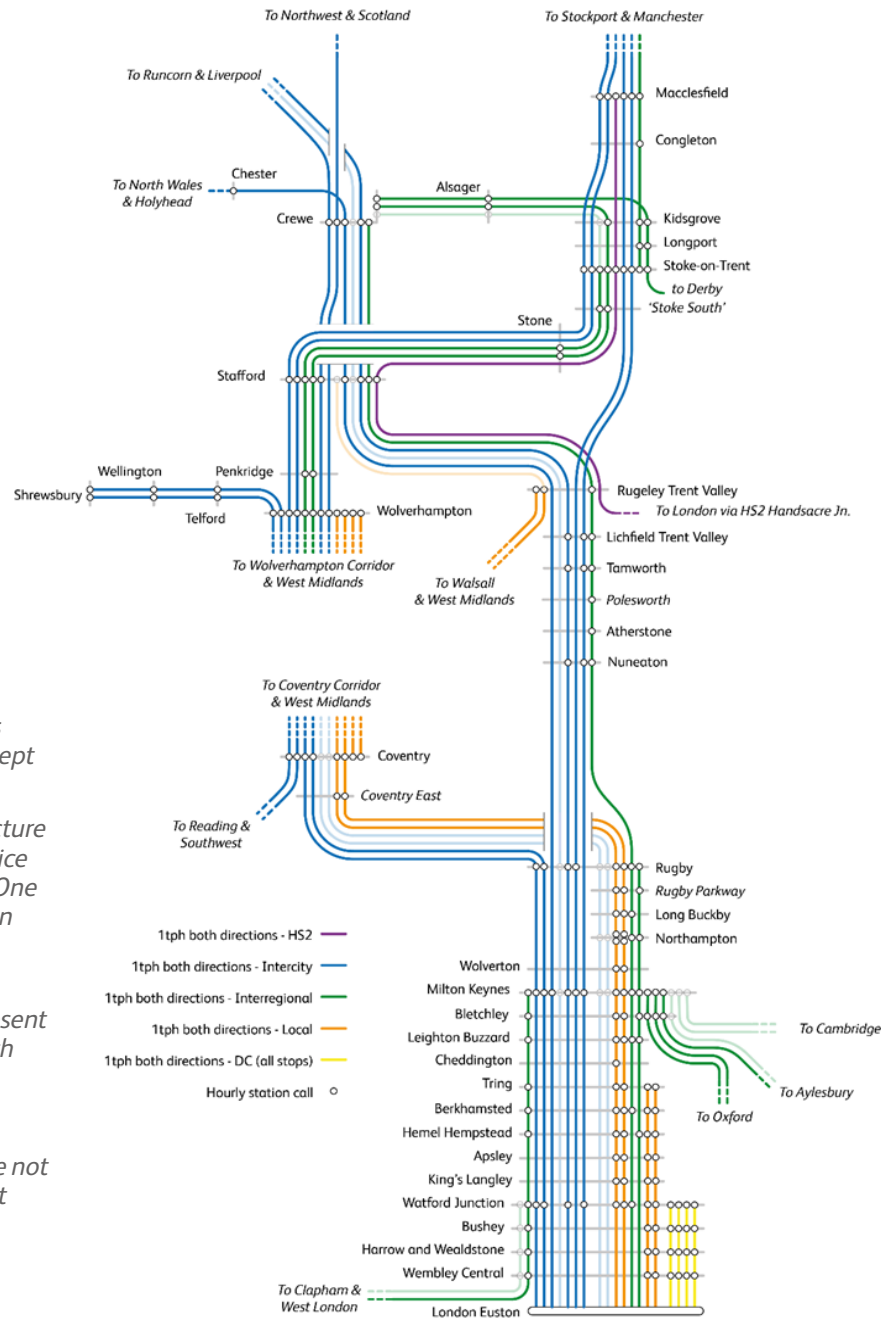

Figure 31: Freight focus released capacity concept train plan.

Passenger service structure shown left, freight service structure shown right. One line represents one train path per hour in both directions.

Transparent lines represent hourly train paths which could not be accommodated on the conventional network infrastructure and were not included in this concept train plan.

Comparative Generalised Journey Times

The capacity released by HS2 was sufficient to provide some significant connectivity improvements for passenger services, even in a freight focused scenario. These are reflected in Table 15 which gives an overview of the main improvements and detriments in Generalised Journey Times compared to the full December 2022 timetable. A full list of GJTs across the scope geography for this scenario is provided in Appendix C.

The increased quantum of calls at Watford served to significantly reduce GJTs to a range of locations further north compared to the December 2022 timetable. Likewise, GJTs were reduced between Shrewsbury and most stations south of Rugby, notably London Euston. In both instances this was due to the creation of direct connections using released capacity which do not exist presently. Other major improvements were observed for principal Trent Valley locations (Nuneaton, Tamworth, Lichfield) driven primarily by increased calls compared to December 2022. Improved options for interchange at Rugby provided significant improvement in GJTs from Northampton to locations to the north, even with the service trade-offs described above.

The reduction in GJTs was achieved here by incorporating the minimum passenger service requirements defined in the Planning Principles. This evidenced the potential to provide significant improvements in passenger connectivity in any scenario using the capacity released by HS2.

However, some significant detriments were observed. The removal of the direct connection between Leighton Buzzard and Birmingham had an acute impact and could be redressed with some calling pattern changes (factored into subsequent passenger-focused scenarios). Increased GJTs were observed for some interregional connections across the route geography. These generally resulted from constraints imposed by the focus on freight which limited the ability to provide faster, intercity-type connections for non-HS2 markets. Connections between, for example, Northampton and Manchester, or London and Stoke-on-Trent could be addressed by introducing additional intercity-type services. This has been explored further in the Intermediate Markets scenario.

Table 15: Freight Focus released capacity headline generalised journey time impacts. These results show changes compared to the December 2022 timetable and give an indication of potential change based on calling patterns assumed in this concept train plan.

Origin	Destination	GJT vs Dec'22
Major Improvements		
Shrewsbury	Milton Keynes	-49
	London	-46
	Rugby	-36
	Coventry	-31
Watford	Lichfield	-63
	Tamworth	-61
	Stoke-on-Trent	-54
	Manchester	-45
Northampton	Liverpool	-43
	Stafford	-33
	Lichfield	-32
	Tamworth	-31
Leighton Buzzard	Shrewsbury	-29
	Stafford	-25
	Lichfield	-22
	Tamworth	-22
Significant Disbenefits		
Birmingham	Leighton Buzzard	+53
Liverpool	Milton Keynes	+36
Stoke-on-Trent	London	+27
Manchester	Northampton	+23
	Nuneaton	+21

Freight Focus: Network Constraints

The most immediate constraint identified in the freight focused scenario was the difference in speed between passenger services (permissible speed or multiple unit differential) and both Class 4 (75mph max) and Class 6 (60mph max) freight. To plan a freight service along the length of route, a significant gap must be found in the train plan before it is caught up by a faster passenger service. On the slow lines between London Euston and Rugby, via Northampton, this problem is mitigated by planning around slower local services which call more frequently as well as flighting freight close together to efficiently utilise the available capacity. This reduces the difference in speeds enabling a more uniform set of timings.

In a freight focused scenario this problem was amplified as more capacity was required for slower moving freight. On the four-track railway south of Hanslope Junction, some interregional services had to run on the fast lines in order to create sufficient slow line capacity for the priority freight services. The consequent effect was constriction of fast line capacity, and the inability to accommodate all the intercity-type services to Crewe and Northampton included in the base ITSS.

Class 6 freight compounded this issue due to the lower maximum speed and the need to use more network capacity per train kilometre travelled. Introducing an additional Class 6 path from London (per the base ITSS) required further reduction in passenger service – beyond a comparable-to-December 2022 level – to create more capacity for freight or the removal from

the plan of three Class 4 paths from London. In the case of the latter, the trade-off was driven by the need to closely flight Class 4 services together in a concept train plan and the inability of a Class 6 service to keep to the same timings which, for example, took a further ten minutes to arrive at Hanslope Junction after departing London when compared to a Class 4 path following the same routing.

The constraints driven by the speed differential between freight services highlights the need for a national freight routing strategy which could determine a more efficient way to use network capacity in a high freight growth scenario. This may involve formally segregating freight classes to specific times of operation, or to specific routes; i.e. reserving standard hour West Coast freight operations for 75mph max Class 4 traffic only and routing Class 6 services elsewhere.

This problem was also exacerbated by the four-minute ruling headway (the time allowed between trains moving in the same direction) for all services on the slow lines, compared to three minutes on the fast lines. A reduction in slow line headways could create more flexibility to plan additional service by closing the gap between them. However, a full replan would be required to establish whether this capacity is usable in reality. A conventional re-signalling project should not be prioritised at this stage as the planned roll-out of ETCS digital signalling presents an opportunity reduce headways, and resolving physical constraints elsewhere is likely to generate usable capacity through alternative routes.

Bletchley to Milton Keynes

The freight focus planned passenger and freight services on to the West Coast Main Line via East West Rail. Capacity was available to plan three passenger services to Milton Keynes Central from Oxford (2tph) and Aylesbury (1tph) in this scenario. However, uplifting freight on the trunk route alongside this service level created a capacity bottleneck between Bletchley and Milton Keynes, where insufficient track capacity remained to plan this level of service together, as well as a lack of platform capacity to plan through passenger and freight alongside terminating local services from London.

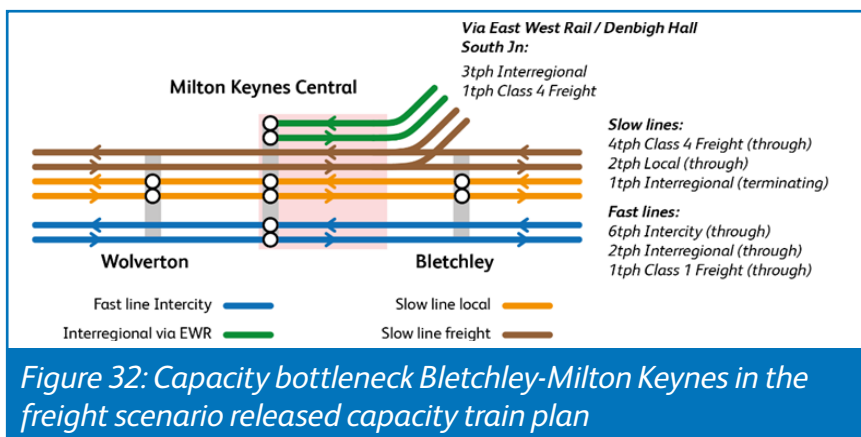

Prioritising more than 3tph East West Rail passenger services to Milton Keynes would require removal of suburban-type services from Euston, effectively breaking the minimum passenger services requirements and undermining the ability to provide a comparable level of service to the December 2022 timetable.

This could be mitigated by terminating some suburban services from London further south at Bletchley. However, the need for a double interchange for passengers north of Milton Keynes to reach suburban locations to the south would represent a reduction in connectivity as well as contravene the minimum requirements laid out in the Planning Principles governing this work.

Northampton Loop

The released capacity train service included five Class 4 freight paths per hour through the Northampton slow lines. This could be compliantly planned on the existing infrastructure but did require a trade-off against the passenger service and did not leave sufficient capacity to plan a second Class 4 freight path from East West Rail, per the base ITSS. One option to relieve this constraint would be to plan more freight on the fast lines via Weedon. This was a feasible alternative within the testing due to:

- A lower quantum of passenger service running via the fast lines when compared to the December 2022 timetable which left spare capacity available for other uses,
- The physical performance of electric traction freight locomotives (compared to diesel) which reduced the transit time between Hanslope Junction and Rugby,

However, fast line routing could not be realised immediately due to a specific limitation imposed by the Rugby to Nuneaton three-track section.

Rugby to Nuneaton

The four-track formation on West Coast South provides good flexibility by separating service types across fast and slow lines. However, there is a seven mile long three-track pinch point between Rugby and Nuneaton where both northbound lines converge prohibiting northbound trains from passing each other. This was acutely constraining in the freight focused scenario, where freight services which have departed London needed to be passed in the northbound direction by the following flight of fast intercity and interregional passenger services. In the released capacity concept train plan this was done by holding freight services just south of the three-track section north of Rugby and releasing them through the three-track section once the next passenger flight has run through, as demonstrated in Figure 33.

This was found to be sufficient for the five Class 4 trains per hour undertaking this movement through Rugby. However, the physical limitations of space and the associated signalling arrangements meant no additional freight services could be held in this way without backing up through Rugby station and therefore precluding passenger services from running compliantly between Northampton and Coventry. This would again have the effect of breaking minimum passenger requirements, as well as representing a sub-optimal outcome for local rail operations.

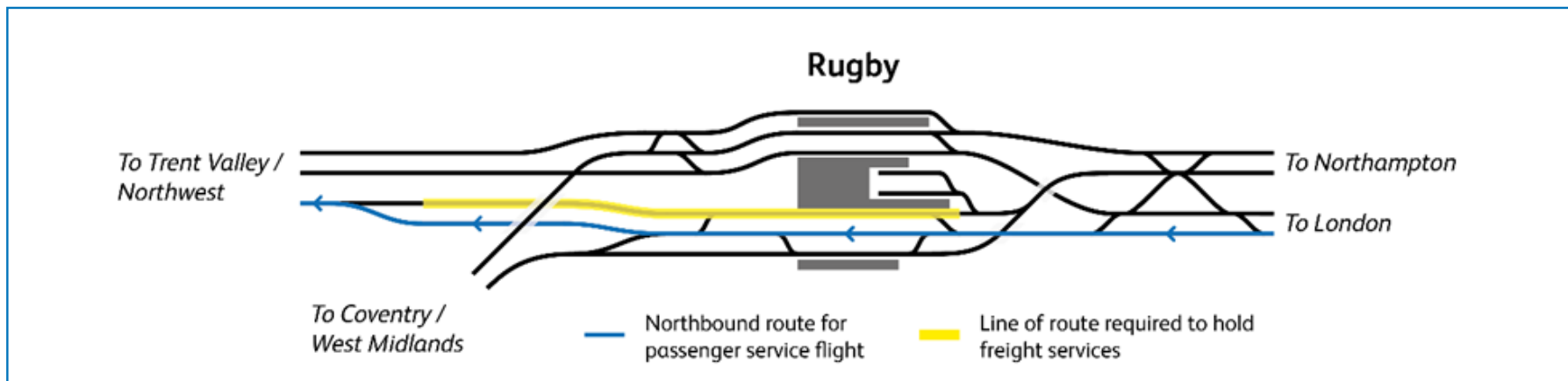

Figure 33: Capacity impact at the Rugby to Nuneaton three-track section in the freight scenario. Layout not to scale.

Freight Focus: ‘With Infrastructure’ Train Service

Infrastructure intervention was required to provide the capacity for the services that were deprioritised in this scenario. This focused primarily on infrastructure between Bletchley and Milton Keynes, opening sufficient capacity and flexibility to plan additional freight by East West Rail, as well as additional looping capability on the fast lines via Weedon.

The results of the multi criteria economic assessment showed a moderate increase in overall benefits for freight. This was a product of the inclusion of the second Class 4 freight path to Crewe via East West Rail and Northampton which required not only resolution of the Bletchley-Milton Keynes capacity bottleneck, but also a northbound freight loop on the fast lines to overcome both the constraints at Northampton and the three-track section Rugby-Nuneaton.

The infrastructure interventions identified - while driven primarily by the freight requirement in this scenario - also had the effect of freeing capacity for additional passenger services via East West Rail and more fully conforming to the Milton Keynes ‘hub’ concept outline in Planning Principal B. The improvements in the Stimulate New Markets objective was driven by the direct connectivity provided between Milton Keynes, Bedford and Cambridge as well as elimination of the need for double interchange across Milton Keynes and Bletchley for a range of West Coast South-East West Rail flows.





The improvement in the freight results appear to be limited in the with infrastructure concept train plan. This is due primarily to the very significant uplift already included in the released capacity train plan, reducing the comparative improvement associated with an additional hourly Class 4 path. The results suggest that very significant benefits are available if prioritising released capacity for freight, but that long-term improvement commensurate with a high-growth forecast will require generation of alternative routings, most effectively provided by concentrated investment in the Bletchley-Milton Keynes area.

Table 16: Freight Focus 'with infrastructure' train service multi-criteria assessment results.

Freight Focus 'with infrastructure' concept train plan results (all results relative to Freight Focus released capacity concept train plan)

Service Changes

- +1tph Class 4 freight Felixstowe - Crewe
- +1tph Interregional Aylesbury - Milton Keynes Central
- +2tph Interregional Cambridge - Milton Keynes Central

Objective	Multi-Criteria Assessment Measure	Additional % vs released capacity
	<p>Maximise Revenue</p> <p>Total forecasted revenue generated from passenger abstractions.</p>	+0.9%
	<p>Supporting Development</p> <p>Forecasted value of time (VoT) benefits weighted for relative deprivation for each corresponding origin and destinations.</p>	+1.9%
	<p>Encourage Modal Shift</p> <p>Total passenger miles abstracted from road to rail.</p>	+0.1%
	<p>Stimulate New Markets</p> <p>Total value of time benefits for flows classified as new markets, either not directly connected or not frequently served.</p>	+8.0%
	<p>Support Freight Growth</p> <p>Total freight marginal external costs (MEC) benefits measured by the emissions reduced through modal shift from road to rail.</p>	+2.6%

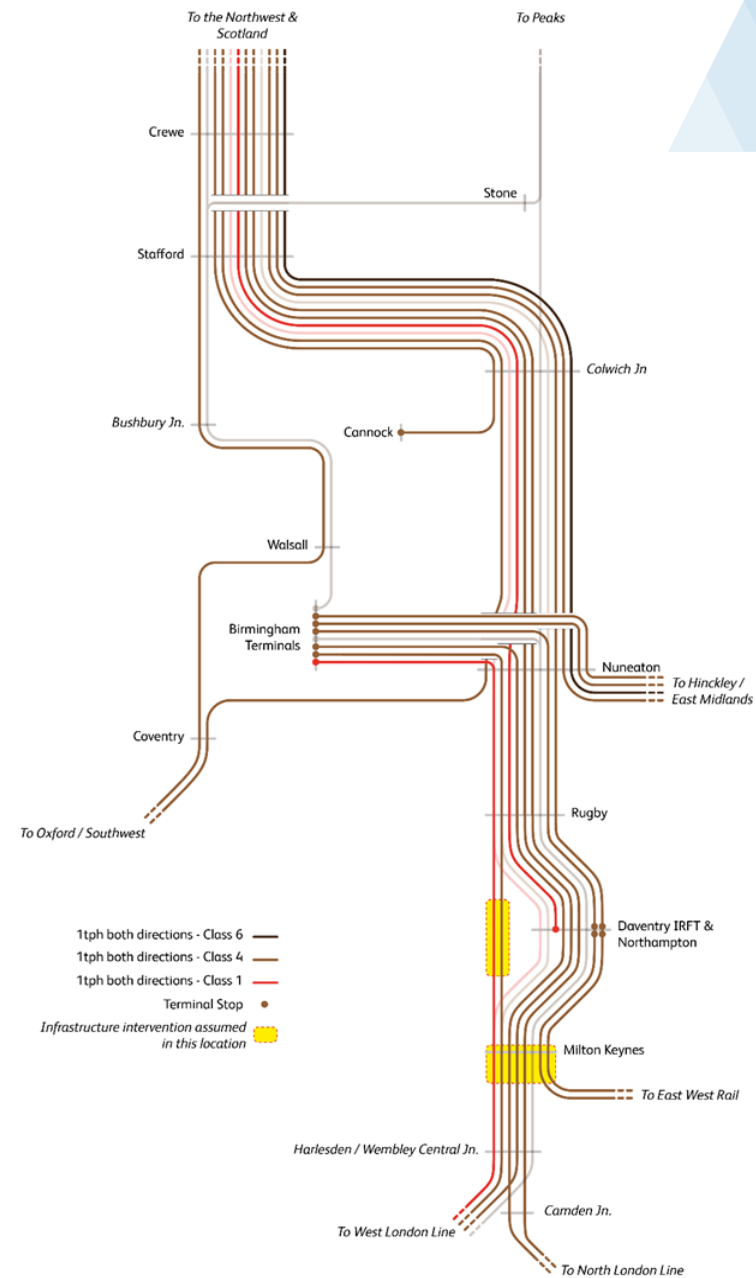
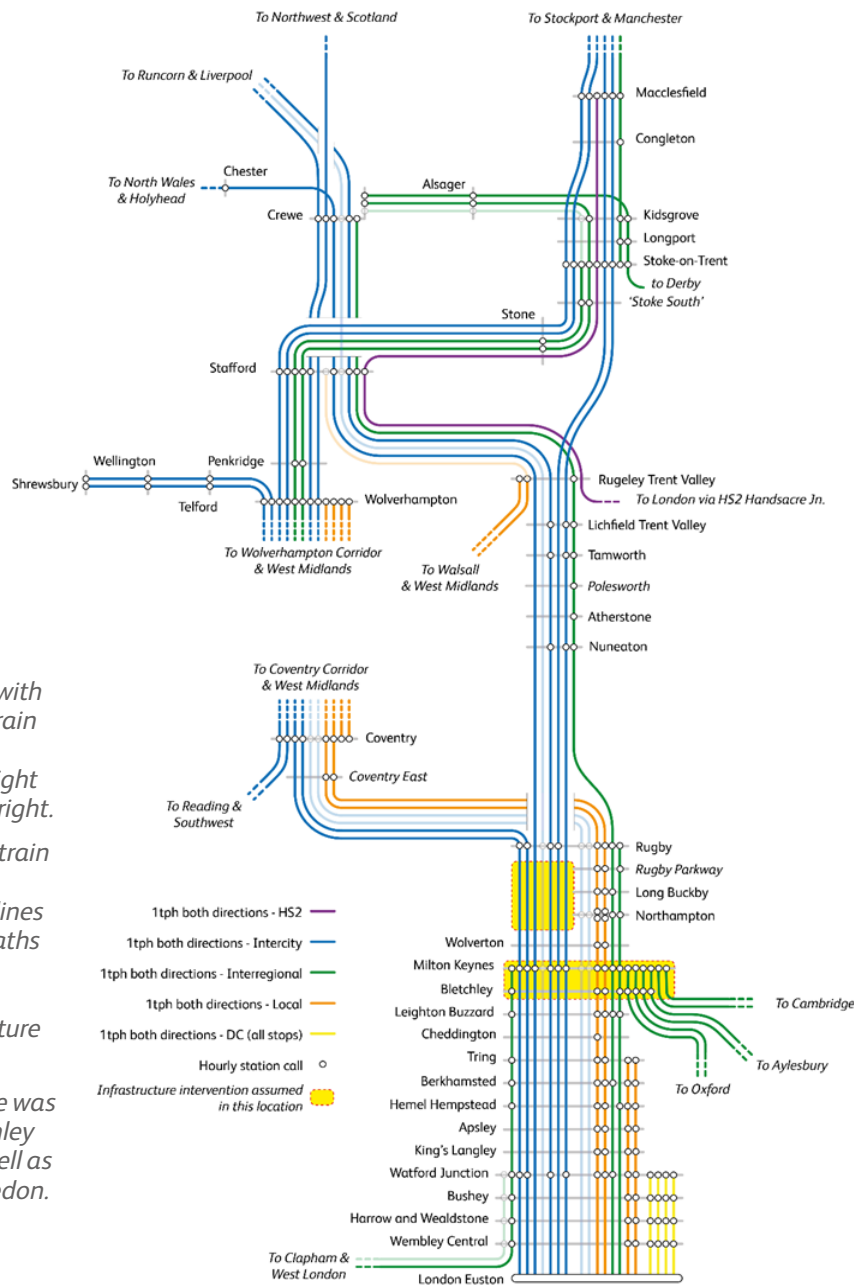

Figure 34: Freight focus with infrastructure concept train plan. Passenger service structure shown left, freight service structure shown right.

One line represents one train path per hour in both directions. Transparent lines represent hourly train paths which could not be accommodated when assuming the infrastructure interventions identified.

Additional infrastructure was required between Bletchley and Milton Keynes, as well as on the fast lines via Weedon.

The interventions tested in this scenario addressed the most immediate constraints. Additional track between Bletchley and Milton Keynes was required to include a second Class 4 freight paths via East West Rail, as well as additional passenger services from Aylesbury and Cambridge via East West Rail specified in the ITSS.

Fifth track Bletchley to Milton Keynes as well as two new platforms at Milton Keynes Central provided the ability to move East West Rail passenger services terminating at Milton Keynes out of the existing platforms, as well provide track capacity for an additional passenger service from Aylesbury to Milton Keynes. However, running an hourly freight service in both directions along what would be effectively a single line between Bletchley and Milton Keynes precluded the ability to plan additional passenger services from the Cambridge direction, or the second hourly freight service via East West Rail.

This was resolved comprehensively through a sixth track option which segregated all East West Rail passenger services from the West Coast South lines and provided sufficient track capacity for all six passenger services from Oxford, Aylesbury and Cambridge. The sixth track option also generated sufficient residual capacity for the second hourly freight service from East West Rail. However, the second Class 4 freight path could not be planned compliantly beyond Milton Keynes due to the volume of traffic via the Northampton slow lines in the released capacity plan, and the inability to hold an additional freight service ahead of the Rugby-Nuneaton three-track section in the northbound direction.

This further constraint was resolved by providing a northbound freight loop on the fast lines near Rugby, generating sufficient flexibility to plan one of the existing freight services via the fast lines and free another freight path via Northampton. Intervention here was useful because of the lower quantum of intercity-type passenger services on the fast lines in a freight-focused scenario which meant a re-routed freight service could meet timings from Hanslope Junction to the assumed new freight loop without compromising other passenger services.

The most direct routing option for any additional passenger or freight services from the east via East West Rail would be provided by a northeast chord at Bletchley. It is recommended that the development of a chord at Bletchley which provides new direct routing options is undertaken alongside the set of infrastructure options between Bletchley and Milton Keynes identified above, given the potential capacity constraints observed on the existing main line infrastructure. This is most likely to compound the benefits associated with the investment by providing for a range of additional passenger and freight connections, and contributing to centring Milton Keynes as a focal point for the West Coast South and East West Rail networks.

No major interventions were required to the north of Rugby, where the capacity released by HS2 was sufficient to meet the requirements for freight set in this scenario. Again, this demonstrates the need to develop alternative routing options to maximise the benefits associated with released capacity,

Table 17: Infrastructure required to deliver the Freight Focus ‘with infrastructure’ concept train plan.

Freight Focus Infrastructure Options Results	
Infrastructure Intervention	Train Service Impact
Bletchley-Milton Keynes Fifth Track	+1tph Aylesbury-Milton Keynes Central <i>Performance / Resilience improvement through released capacity at MKC station.</i>
Bletchley Milton Keynes Sixth Track	+1tph Aylesbury-Milton Keynes +2tph Cambridge-Milton Keynes Central* <i>Performance / Resilience improvement through released capacity at MKC station.</i> <i>*Passenger services from Cambridge direction would require Bletchley Northeast Chord for the most direct routing</i>
Weedon Fast Line Loop (Northbound)	+1tph Class 4 Freight Felixstowe-Crewe/Northwest* <i>*Freight services from Felixstowe would require Bletchley Northeast Chord</i>
Bletchley Northeast Chord	+2tph Cambridge-Milton Keynes Central <i>Requires Bletchley-Milton Keynes sixth track to unlock sufficient main line capacity for Cambridge trains.</i> <i>Additional routing option for 1tph Class 4 freight planned into the released capacity train service.</i> <i>Additional routing option for +1tph Class 4 freight achievable with sixth-track and fast line loop options.</i>

where maximum capability will be reached on the route further south into London. Any major uplifts beyond the levels planned in this work could drive the need for further intervention, but the bottleneck identified between Bletchley, Milton Keynes and Rugby will always need to be resolved first.

All the infrastructure interventions considered above have been explored in further detail in section 6.2 of this report where more detail on requirements, scope and order of magnitude cost can be found, as well as the summary cross-scenario infrastructure option assessment which acts as a basis for recommended further development work.

Freight Focus: Scenario Summary and Recommendations

The testing undertaken in this scenario demonstrated some key findings and recommendations. Firstly, that even in a freight focused scenario, HS2 Configuration State G releases sufficient conventional network capacity to deliver level of freight broadly commensurate with a high-growth forecast alongside the minimum passenger requirements outlined in the planning principles governing this work.

This does however, result in more trains planned into Crewe and Manchester than can be accommodated at those points of the network at Configuration State G as established by other work undertaken by Network Rail. The delta between what could be accommodated and what could be planned from West Coast South route in the released capacity concept train plan is shown below:

Table 18: Freight Focus released capacity concept train plan services planned into Crewe and Manchester.

Interface	Configuration State G current assumptions	WCSSA Freight Focus released capacity	Difference
Crewe via Stafford	5tph passenger	5tph passenger	<i>nil</i>
	5tph freight	9tph freight	<i>+4tph</i>
Manchester via Stoke	4tph passenger	5tph passenger	<i>+1tph</i>

There is clearly then an imperative to **deliver HS2 Phase 2B Crewe-Manchester (Configuration State H) in full** as well as a need to release further capacity beyond Crewe to intermodal ports in the Northwest, or via West Coast Mainline North to Scotland if the capacity released for freight on West Coast South is to be fully utilised with end-to-end uplift in freight service. While these issues have emerged in all scenarios tested, there is particular need to address them in a freight focused scenario given the national routings and capacity require for freight services which cannot be readily confined to a single route geography like West Coast South.

Further, the results of this scenario demonstrated the extent to which the route section between London and Milton Keynes will remain constrained post-HS2. Supporting long-term freight growth will be most effectively achieved by using released capacity to support alternative routing options for freight via the F2MN route to Nuneaton as well as via East West Rail.

As in all scenarios tested, the capacity released by HS2 could also be used to provide an uplift in passenger service via Stoke-on-Trent. While this is shown to be compliant without additional infrastructure in the testing, Network Rail is aware of a set of aspirations for service improvement in the area which may not be possible to accommodate without further local intervention. Assessment of post-HS2 infrastructure requirements at this point of the network will be provided separately by Network Rail in its forthcoming **Stoke Area Strategic Advice**, building on the findings of this report as a baseline.

Prioritising additional freight in the with infrastructure testing in this scenario resulted in interventions in the Bletchley-Milton Keynes area, which could also be utilised for significant passenger service improvements, as well as a northbound freight loop on the fast lines via Weedon. The combination of these interventions meant freight paths could be transferred from the slow lines via Northampton freeing capacity in a constrained area and generating sufficient capability for an overall uplift in freight capacity for freight via East West Rail.

Implementation of these interventions would of course require a replan of the timetable to ensure that their utilisation is maximised. In relation to planning for freight the most efficient use of capacity should account for the difference in speeds between types or classes of freight. This should be explored as part of a wider freight routing strategy which ensures the benefits associated with released capacity and any further enhancements are maximised.

The findings of this scenario have contributed overarching recommendations made in this report which can be found in section 6. More detail on each infrastructure enhancement identified, and their relative priority alongside the results of the other scenarios, is captured in section 6.



Scenario Two: Intermediate Markets

Scenario Focus

Improving connectivity for established intermediate markets which will not be connected directly by HS2

Testing Purpose

Improve generalised journey times between urban centres, both internal and external to West Coast South route, which will not be connected directly by HS2.

Determine what train service trade-offs or infrastructure is required to improve intercity and interregional connections on the conventional network post-HS2.

ITSS Guiding Objective

Train service structure targets high priority **revenue** flows identified in the economic opportunity analysis.

Train Service Priorities

Prioritisation of intercity and interregional passenger service types in concept train planning.

Rationale

The second scenario tested in the WCSSA workstream focused on improving ‘intermediate markets’ for passenger service. High priority was given to improving connections and frequency between existing markets which will not be served directly by HS2, incorporating service uplifts for intercity and interregional type services whilst also protecting headline journey times between major urban centres served directly by conventional trains on West Coast South route.

The revenue objective was used to determine the base requirements for this scenario. Origin and destination pairs which were identified as high priority revenue flows within the economic opportunity analysis were targeted for improved passenger service. The requirements for the scenario (as with all ITSSs developed in this work) incorporated the minimum passenger service requirements and at least today’s level of freight provision per the planning principles. Expert advice from industry partners was also sought through the established governance process for WCSSA, as well as drawing on the relevant published strategies (described in section 3 above), to ensure that existing long-term service aspirations were included in the testing.

The primary rationale was to understand how the capability of the existing network infrastructure and the capacity released by HS2 could be used to bolster established markets through improved journey times and frequency. The results demonstrate both the opportunity available to improve the network, but

also evidence the extent of the trade-off when prioritising intermediate markets over freight capacity and routing, wider distribution of connectivity, or supporting new or underserved markets.

The assessment results also showed what the capability of the existing infrastructure will be post-HS2, and where the next set of constraints emerge. The intervention options considered to resolve them were accordingly based on the focus for this scenario, prioritising enhancement options which permitted inclusion of intercity and interregional type services which could not be accommodated on the existing infrastructure initially.

Intermediate Markets: Scenario-Specific Requirements and Base ITSS

The minimum passenger and freight service requirements outlined in the Planning Principles have been included in the base Intermediate Markets ITSS as they have for all ITSSs testing in this work. A series of scenario-specific passenger service requirements have also been set for the Intermediate Markets ITSS, shown in Table 19.

The scenario specific requirements were agreed through the West Coast South Strategic Advice working group to be reflective of the scenario focus on longer-distance and high revenue flows, as well as wider aspirations articulated by the industry in an intermediate markets/revenue focused structure. The additional service requirements are aspirational and, as with all

scenarios tested in this work, required train service trade-offs or infrastructure intervention to achieve the details of which are provided in the following subsections.

No specific train paths were agreed before setting the minimum and scenario-specific requirements. Instead, the base ITSS was constructed from first principles configuring train paths to suit the overarching scenario requirements per the methodology applied to all scenario ITSSs tested in this work.

The full base ITSS for the Intermediate Markets scenario is shown in overview diagram form in Figure 35. The full ITSS in spreadsheet form is attached in Appendix D.

Table 19: Scenario-specific requirements for the Intermediate Markets base ITSS.

Type	tph	Origin	Destination
Any Passenger	6	London	Watford Jn
			Hemel Hempstead
			Berkhamsted
			Leighton Buzzard
			Milton Keynes
Any Passenger	6	Watford Jn	Milton Keynes
Any Passenger	4	London	Northampton
Any Passenger	4	London	Rugby
Limited Stop	4	London	Coventry
Limited Stop	4	London	Nuneaton
			Tamworth
			Lichfield
Limited Stop	1	Watford	Manchester
Any passenger	4	Milton Keynes	Northampton
Limited Stop	2	Milton Keynes	Wolverhampton
Limited Stop	1	Milton Keynes	Liverpool
Any Passenger	4	Northampton	Birmingham
Limited Stop	1	Manchester	Lichfield
			Tamworth
			Nuneaton
Limited Stop	1	Stoke-on-Trent	Lichfield
			Tamworth
			Nuneaton

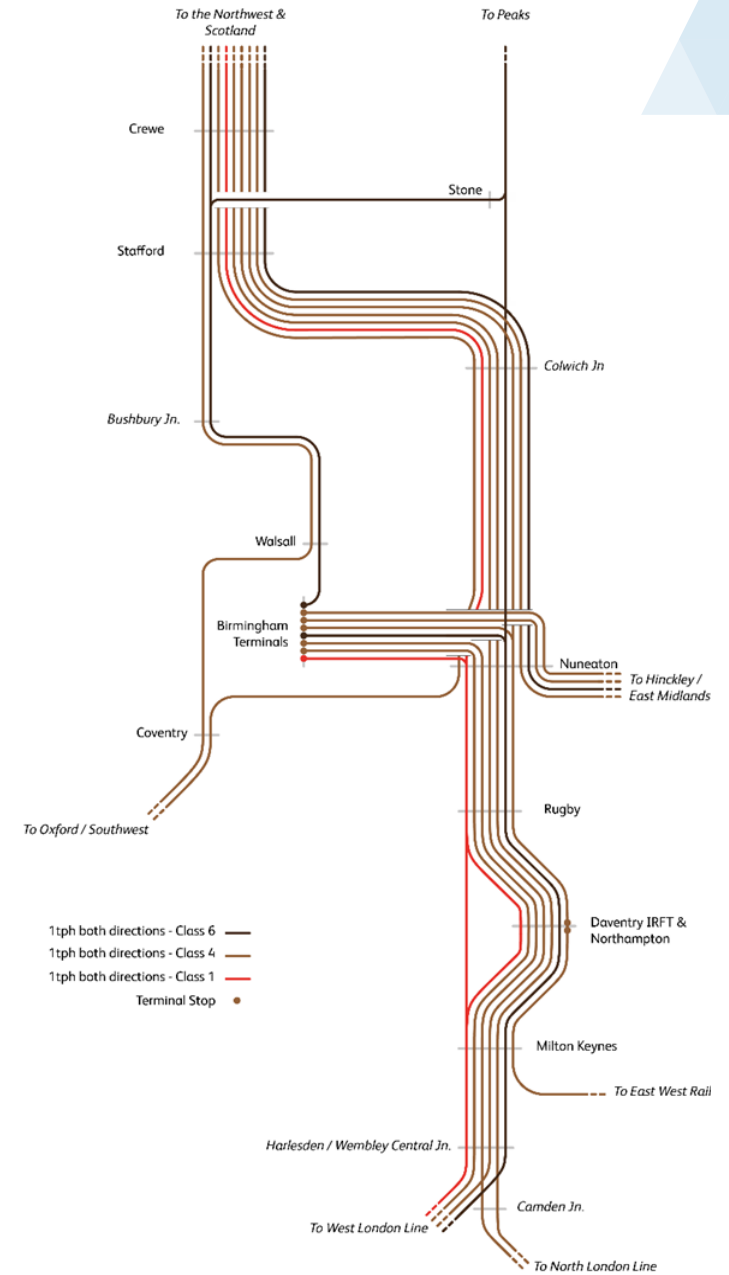
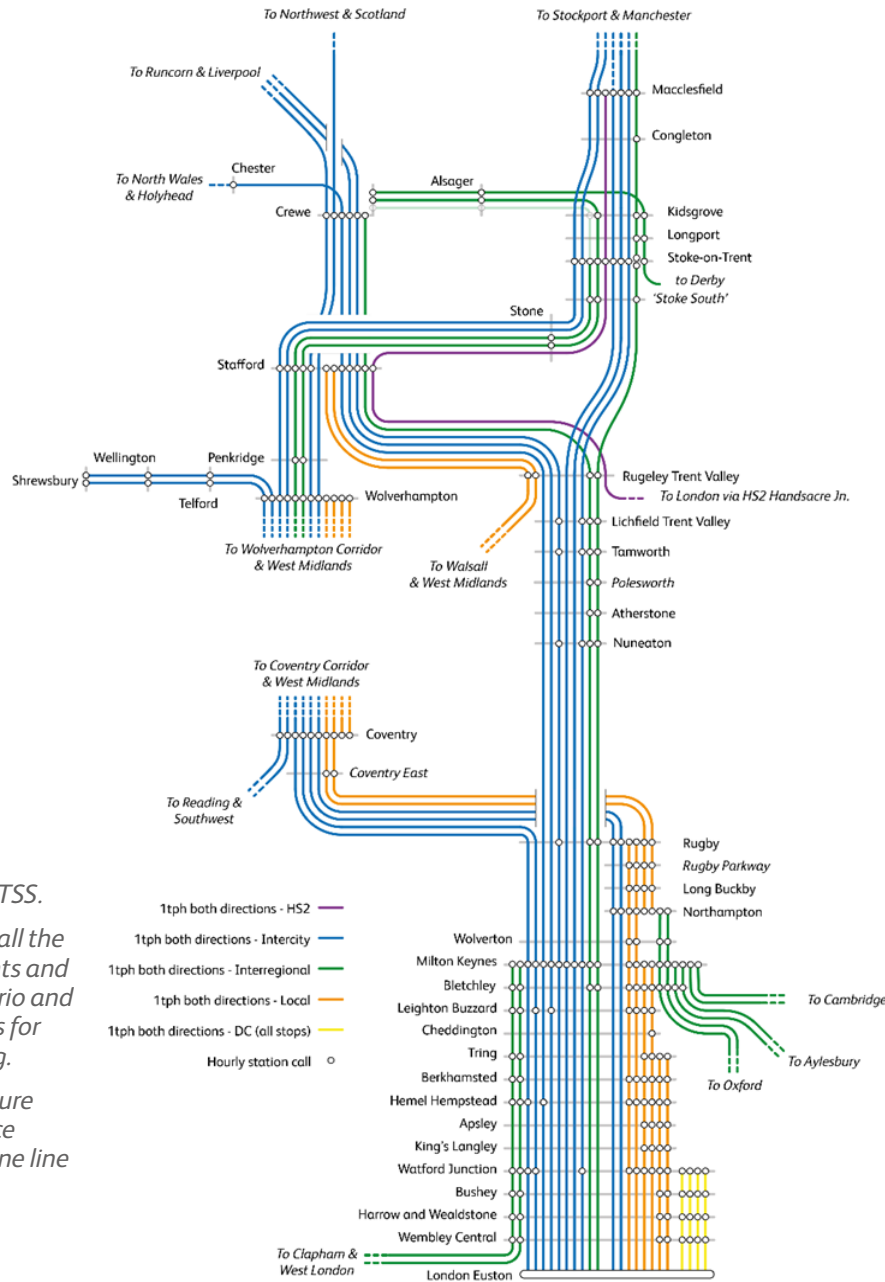

Figure 35: Intermediate Markets scenario base ITSS.

The base ITSS captures all the train service requirements and objectives for this scenario and has been used as a basis for capacity analysis testing.

Passenger service structure shown left, freight service structure shown right. One line represents one train

Intermediate Markets: Released Capacity Concept Train Plan

The released capacity concept train plan focused on prioritising intercity-type services which manifested as a significant improvement against the baseline in the revenue, economic development, and mode shift assessments, as shown in Table 20. The focus on high value passenger services resulted in a more limited benefit in the new markets and freight assessments when compared to the East West Connectivity train plan which targeted this objective. There was however, still a significant improvement from the baseline.

There were significant improvements against all passenger-related objectives in this released capacity concept train plan. The closer flighting of intercity-type trains resulted in a greater quantum of service (twelve intercity/interregional services per hour) between London, the West Midlands and the Northwest via the Trent Valley when compared to the other scenario released capacity train plans. This evidences the trade-off associated between using capacity for a heavily flighted, higher quantum of services on the one hand and expanding connectivity through alternative routings on the other.

This structure was a product of the priority given to intercity and interregional-type services in this scenario, which effectively used all available fast line capacity. Slow line capacity was heavily constrained with limited opportunity to plan crossing moves between fast and slow lines. This prevented two suburban services London-Milton Keynes from being included in the





concept train plan, with the calls redistributed into the London-Northampton suburban services consequently reducing headline journey times for locations served by these trains.

Similarly, the need to confine local services to the slow lines reduced the flexibility to plan additional freight. While there was sufficient capacity for three Class 4 and one Class 1 service per hour from London (a minimal uplift on today's quantum for this line of route), constraints between Bletchley and Milton Keynes meant no freight via East West Rail could be planned in addition. Likewise, the priority given to intercity-type services meant there were ten passenger trains per hour running via Weedon, eliminating the possibility of running Class 4 freight via the fast lines between Hanslope Junction and Rugby in this scenario.

The results of the Intermediate Markets ITSS testing showed significant improvements in connectivity, primarily for longer-distance, interregional flows, as shown in Table 21. The full data can be found in Appendix D.

The observed reductions in generalised journey times across the scope geography were significant. This was made possible by the removal of the fastest, non-stop services to the HS2 network and focusing the capacity released to raise service frequencies at residual, non-HS2 served locations such as Watford, Hemel Hempstead, Milton Keynes, Northampton and stations along the Trent Valley.

Table 20: Intermediate Markets released capacity train service multi-criteria assessment results.

Objective	Multi-Criteria Assessment Measure	(% Change from post-HS2 economic baseline)
	<p>Maximise Revenue</p> <p>Total forecasted revenue generated from passenger abstractions.</p>	<p>5.5%</p>
	<p>Supporting Development</p> <p>Forecasted value of time (VoT) benefits weighted for relative deprivation for each corresponding origin and destinations.</p>	<p>2.3%</p>
	<p>Encourage Modal Shift</p> <p>Total passenger miles abstracted from road to rail.</p>	<p>5.2%</p>
	<p>Stimulate New Markets</p> <p>Total value of time benefits for flows classified as new markets, either not directly connected or not frequently served.</p>	<p>21.6%</p>
	<p>Support Freight Growth</p> <p>Total freight marginal external costs (MEC) benefits measured by the emissions reduced through modal shift from road to rail.</p>	<p>- 1.2%</p>

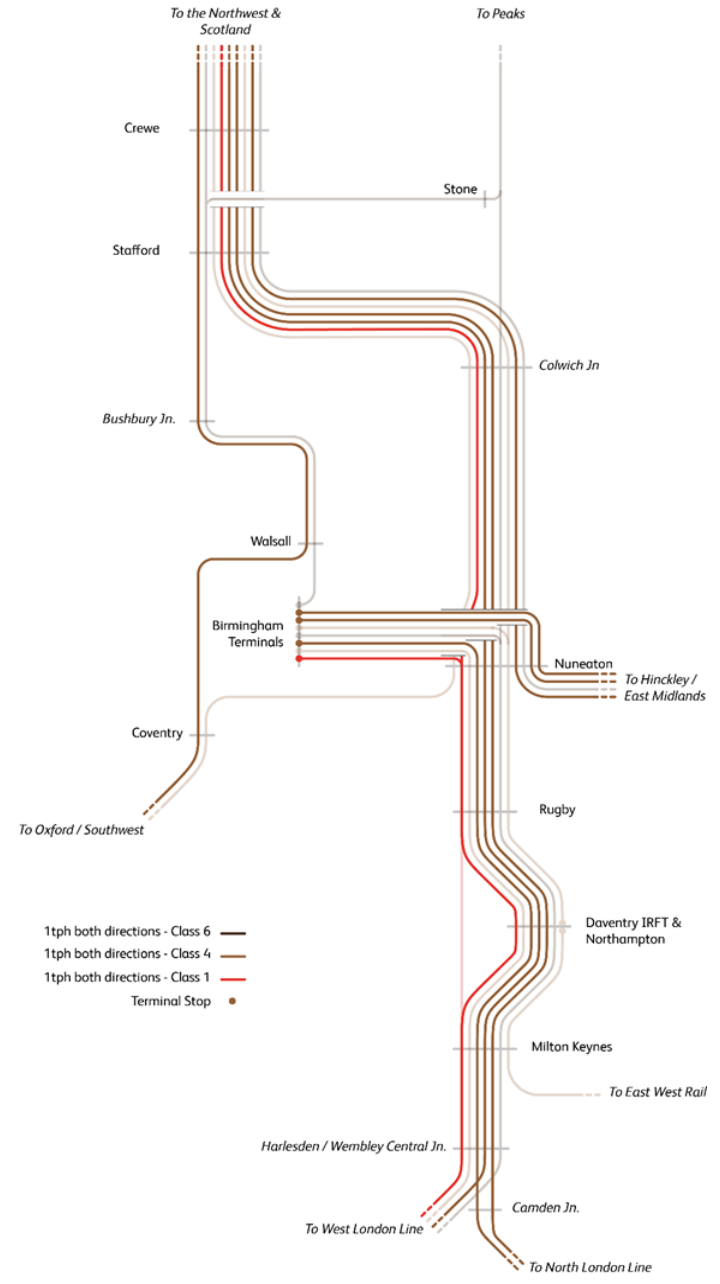
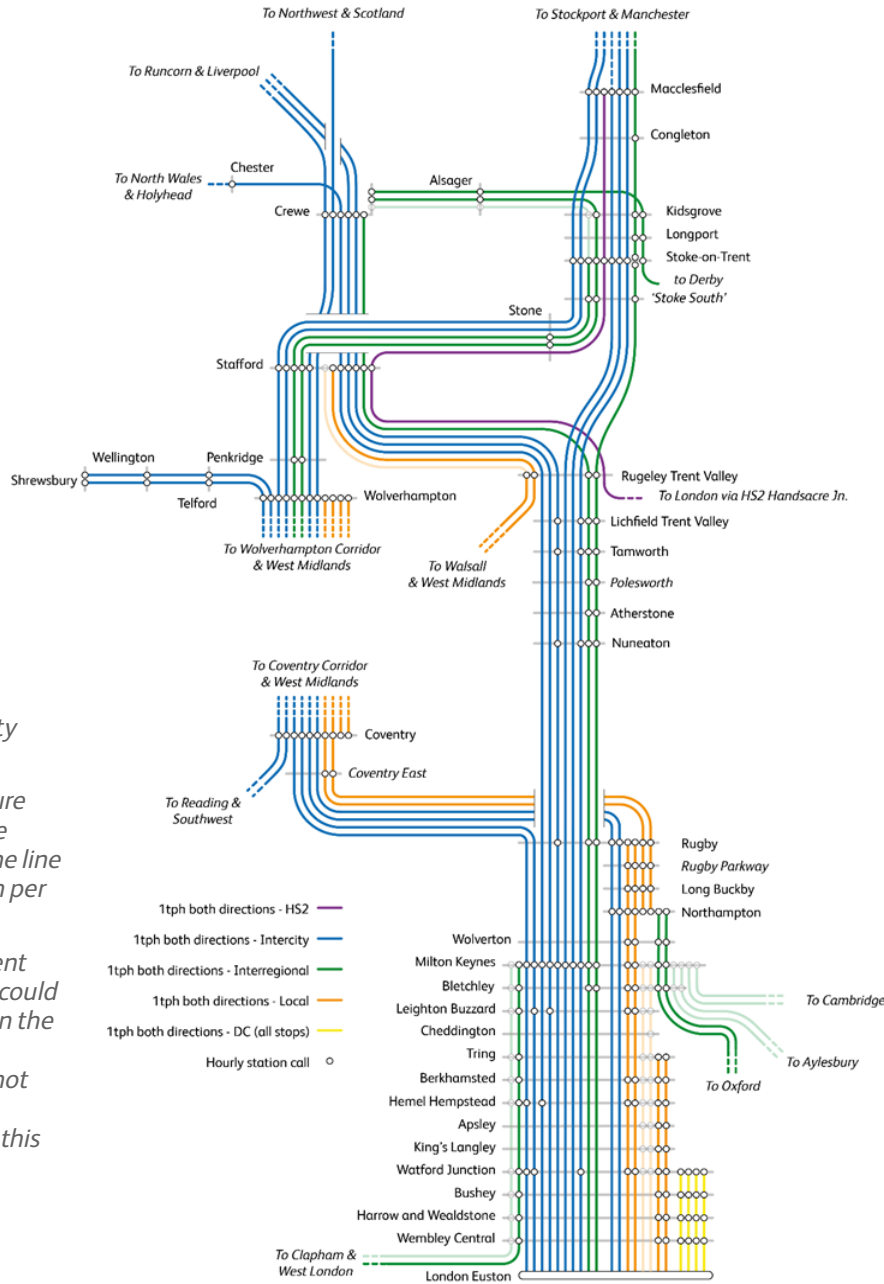

Figure 36: Intermediate Markets released capacity concept train plan.

Passenger service structure shown left, freight service structure shown right. One line represents one train path per hour in both directions.

Transparent lines represent hourly train paths which could not be accommodated on the conventional network infrastructure and were not included in the released capacity train service for this scenario

The widespread reductions in GJTs across the geography were achieved by raising the service frequency (and therefore reducing the service displacement penalty) for a range of origin/destination pairs, and consequently by improving options for interchange at locations like Rugby and Milton Keynes. The result was a transformative reduction in GJTs across most locations, with some more focused improvements for flows where additional services significantly raised frequency or created new direction connections which do not exist in the December 2022 timetable.

An increased quantum of calls could be provided at locations further south, significantly improving connectivity between Watford, Leighton Buzzard, Hemel Hempstead and Milton Keynes and most other locations included in the scope geography. At Tamworth, Nuneaton and Lichfield GJTs to locations to the north and south were significantly reduced through provision of a half-hourly intercity-type service in addition to a 2tph stopping service in this scenario.

The increased quantum of service through Northampton and the improved options for interchange at Rugby resulted in significant reductions in GJTs. However, the constraints on capacity through the two-track Northampton corridor meant services needed to be heavily flighted, reducing the overall gains particularly to London. A reduction in the level of freight service on this line of route could create capacity for a more even interval arrival and departure across all service groups at Northampton, though this would – within this scenario - drive a

wider replan of the train service and import significant GJT and freight disbenefits elsewhere across the route.

Some *increases* in GJT were observed compared to the December 2022 timetable, generally limited to flows to Liverpool and Manchester where capacity constraints out of the West Coast South geography meant an uplift in quantum beyond what has been assumed in all scenarios was not possible. Consequently, some increases in *headline* journey time could not be offset by improved frequencies. For example, the combination of increased calls and removal of EPS speeds meant a slight increase in Generalised Journey Times between Milton Keynes and Manchester was observed, despite provision of a 2tph service. Changes to calling patterns could be used to reduce this deficit; namely by removing some Trent Valley intercity-type calls. The results of the testing again show the challenge posed in providing a sufficient level of connectivity for intermediate markets into the Northwest where capacity remains constrained into the post-HS2 period.

Table 21: Intermediate Markets released capacity train service key generalised journey time impacts

Origin	Destination	GJT vs Dec'22 (minutes)
Major Improvements		
Watford	Shrewsbury	-57
	Wolverhampton	-36
	Manchester	-31
Hemel Hempstead	Shrewsbury	-113
	Wolverhampton	-78
	Stafford	-69
	Coventry	-42
Milton Keynes	Stoke-on-Trent	-70
	Shrewsbury	-46
	Wolverhampton	-31
Northampton	Liverpool	-31
	Lichfield	-25
	London	-20
Tamworth	Manchester	-43
	Stoke-on-Trent	-41
	Watford	-30
	Milton Keynes	-24
Significant Disbenefits		
Manchester	Rugby	+25
	Milton Keynes	+12
Liverpool	Milton Keynes	+16
	Leighton Buzzard	+12

Intermediate Markets: Network Constraints

Not all passenger services could be planned between London and Milton Keynes per the base ITSS, in part due to the speed differential between 110mph-capable passenger and 75mph-capable freight trains and the consequent need to find a large enough gap between passenger services for a slower moving freight.

While this problem was amplified by the four-minute headway on the slow lines between London and Milton Keynes, it is not clear if reducing headways through a major re-signalling scheme or ETCS rolling could generate any additional capacity. This would require a replan to understand, however it is clear that the immediate constraints pertained again to the Bletchley-Milton Keynes area, where a physical track capacity bottleneck emerged, and then further north at Colwich Junction and Stoke-on-Trent.

Bletchley to Milton Keynes

The route section between Bletchley and Milton Keynes imposed a significant constraint in the intermediate markets scenario, where there was insufficient slow line capacity to plan a 2tph East West Rail service alongside all suburban London-Milton Keynes services specified in the base ITSS, forcing the removal of 2tph London-Milton Keynes services in the released capacity concept train plan.

Insufficient slow line capacity approaching Milton Keynes also meant no freight via East West Rail could be planned in this

scenario, though the ability to plan the additional freight path via East West Rail was precluded elsewhere across the scope geography. The priority given to an uplifted quantum of intercity and interregional-type services means capacity on the fast lines via Weedon as well as on the four-track Trent Valley lines north of Rugby was much more heavily utilised in this scenario.

Resolution of the capacity bottle-neck Bletchley to Milton Keynes would be insufficient to realise an additional freight path alone, however even in a scenario focused primarily on intercity-type passenger services intervention at Bletchley and Milton Keynes could offer a valuable alternative routing option for freight in lieu of a path already planned on the trunk route, potentially reducing slow line pressure immediately north of London.

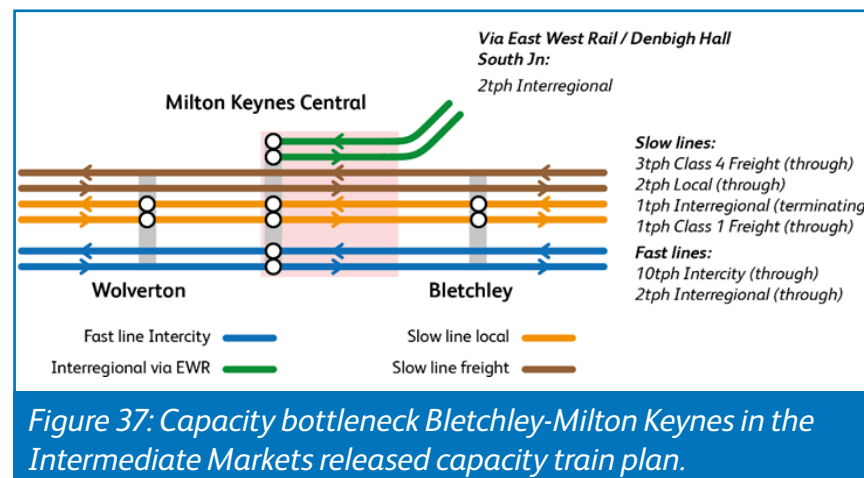

The constraints encountered between Bletchley and Milton Keynes also prevented inclusion of any more than 2tph Oxford-Northampton services via East West Rail. Integrating the East West Rail and West Coast South networks (without infrastructure investment) was found to be highly challenging in a scenario focused on used trunk West Coast Main Line capacity to serve intermediate markets. Further, while these identified services could be compliantly planned, this required absorption of a very high rate of capacity utilisation at Milton Keynes Central which could present a risk to performance over the long-term.

Colwich and Rugeley North Junctions

The prioritisation of intercity and interregional-type passenger services created a train service structure that was more heavily flighted along the trunk West Coast South route than in other scenarios. This resulted in a concept train plan that included a greater quantum of passenger services following closely together through the Trent Valley lines when compared to the previous Freight Focus scenario. Ten passenger services as well as four freight services (per hour in both directions) were planned through Colwich Junction where the four-track Trent Valley lines diverge into the Stafford and Stoke lines. While the relevant paths could be compliantly planned, it did represent a potential risk when factoring in the number of crossing moves required.

Only one of the two hourly services from Walsall via the Chase Line specified in the base ITSS could be planned on to the West Coast Main Line. This was due both to the single lead at Rugeley North junction and inability to find a slot through Colwich junction.

Stoke-on-Trent Area

The base ITSS for this scenario sought to address the intermediate market between London/Milton Keynes and Stoke-on-Trent by providing an uplift in intercity and interregional-type passenger services comparative to the other scenario ITSSs. All passenger services specified (including the 1tph HS2 service via Handsacre Junction) could be compliantly planned to Stoke-on-Trent. However, some services were planned to terminate at Stoke-on-Trent station meaning either a turnround on one of the through platforms, or an empty coaching stock move into a siding; neither of which are capacity optimal or performance-robust solutions. This was due to specific local constraints driven by the Alsager single track section which precluded accommodation of these services in the bay platforms at Crewe.

A more geographically focused strategic assessment is required for the Stoke-on-Trent noting that any additional local services not captured in the base ITSS for this work (e.g. via the North Staffs line from Derby to Crewe) may not be deliverable alongside those planned in this released capacity concept train plan. The requirement for this further study has been captured in the recommendations and next steps in sections 6 and 7 respectively.

Intermediate Markets: ‘With Infrastructure’ Concept Train Plan

Infrastructure was required in the Intermediate Markets scenario to address the significant constraint identified between Bletchley and Milton Keynes. This permitted inclusion into the with infrastructure train plan of the specified passenger services via East West Rail (including those nominally from the Cambridge direction), as well as the two local services London-Milton Keynes.

Intervention at Colwich and Rugeley North junctions – combining the two into a more flexible layout – had a material impact in permitting a second Chase Line services through to Stafford, generating some moderate benefits in the economic assessment by providing for a half-hourly local service as well as onward connections from the Black Country at Stafford.

The multi criteria results generated following these train service changes is shown in Table 22. There were notable improvements in the passenger-related objectives derived primarily from the inclusion of additional local services from London Euston, as well as inclusion of the full 6tph interregional service via East West Rail specified in the base ITSS. Inclusion of the East West Rail services was largely responsible for the significant improvement in the New Markets objectives, both generating new direct connections and compounding the benefit of a single point of interchange at Milton Keynes Central.

There was no improvement in freight benefits relative to the

released capacity concept train plan for this scenario. While this still represents an uplift on today’s provision, it demonstrates the extent to which prioritising a heavily flighted intercity-type service on the conventional network generates a direct trade-off for freight, by limiting capacity via the Weedon fast lines, Northampton and on the Trent Valley. Even with the infrastructure options identified, provision of additional freight service would require substitution of a priority service to achieve a compliant, end-to-end path.





Table 22: Intermediate Markets 'with infrastructure' train service multi-criteria assessment results.

Intermediate Markets 'with infrastructure' concept train plan results (all results relative to Intermediate Markets released capacity train plan)

Service Changes

- +2tph Interregional Aylesbury - Milton Keynes Central
- +2tph Interregional Cambridge - Milton Keynes Central
- +2tph Suburban London Euston - Milton Keynes Central

+1tph Suburban Walsall - Stafford

Objective	Multi-Criteria Assessment Measure	Additional % vs released capacity
	<p>Maximise Revenue</p> <p>Total forecasted revenue generated from passenger abstractions.</p>	+3.3%
	<p>Supporting Development</p> <p>Forecasted value of time (VoT) benefits weighted for relative deprivation for each corresponding origin and destinations.</p>	+4.5%
	<p>Encourage Modal Shift</p> <p>Total passenger miles abstracted from road to rail.</p>	+1.8%
	<p>Stimulate New Markets</p> <p>Total value of time benefits for flows classified as new markets, either not directly connected or not frequently served.</p>	+11.3%
	<p>Support Freight Growth</p> <p>Total freight marginal external costs (MEC) benefits measured by the emissions reduced through modal shift from road to rail.</p>	+0%

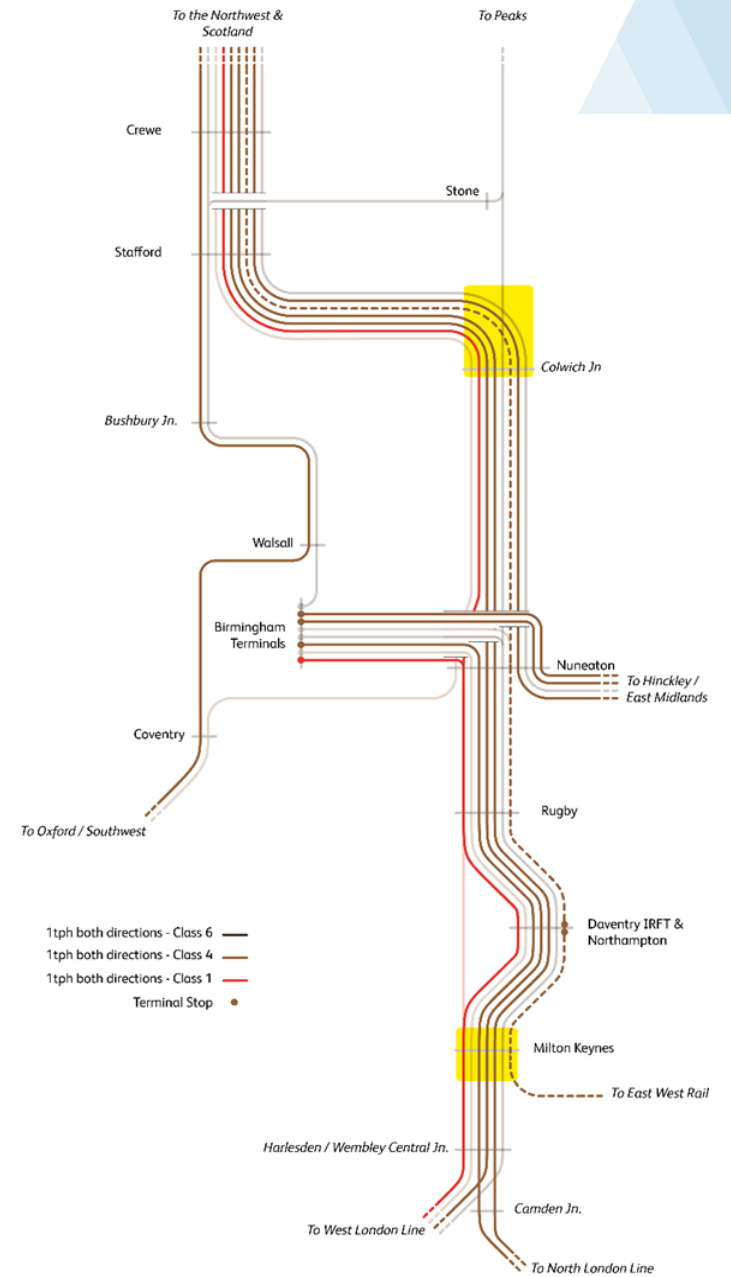
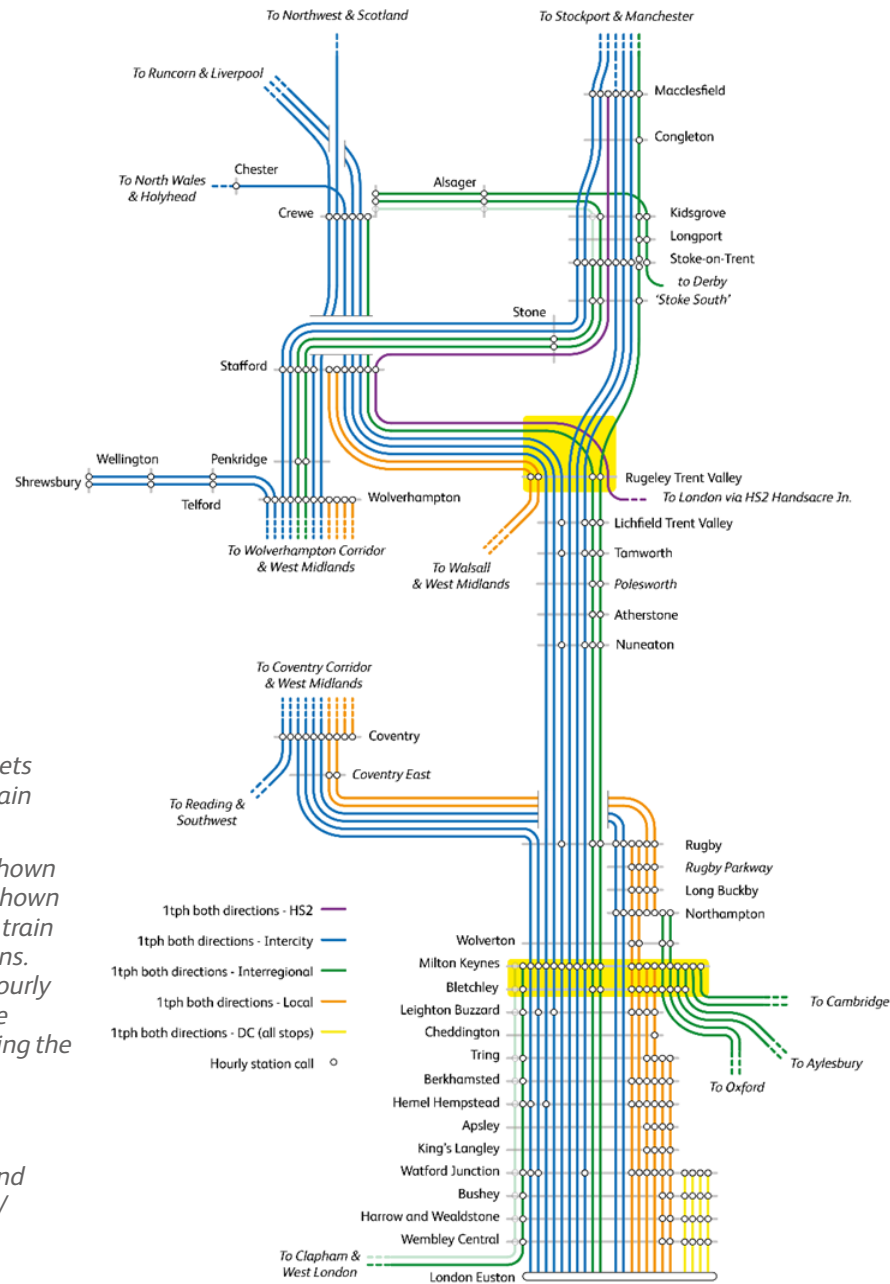

Figure 38: Intermediate Markets with infrastructure concept train plan.

Passenger service structure shown left, freight service structure shown right. One line represents one train path per hour in both directions. Transparent lines represent hourly train paths which could not be accommodated when assuming the infrastructure interventions identified.

Additional infrastructure was required between Bletchley and Milton Keynes and at Colwich/ Rugeley North junctions.

The capacity bottle-neck between Bletchley and Milton Keynes was the immediate constraint in this scenario. A fifth track option between Bletchley and Milton Keynes - with two new bay platforms at Milton Keynes Central - was required to plan the additional four passenger services from Aylesbury and Cambridge. This was achievable due to the absence of freight via East West Rail which would otherwise block the fifth track and reduce the capacity available for additional passenger services.

With fifth-tracking assumed a northeast chord at Bletchley could be utilised by two additional hourly passenger services, nominally Cambridge-Milton Keynes, as well as providing an alternative routing option for freight. However, in this scenario freight via East West Rail would have to take the path of a service already included in the train plan given the route-wide constraints outlined above.

The fifth track option still left a significant trade-off of suburban London-Milton Keynes passenger services which could not terminate in the existing platforms. Providing for two new through platforms at Milton Keynes Central (in lieu of bays) provided much greater flexibility to plan Northampton-bound services and released sufficient platform capacity to get all specified local services London-Milton Keynes compliantly and on an even interval.

The prioritisation of intercity-type services in this scenario also resulted in a greater quantum of long-distance passenger trains

planned through Colwich Junction. As such, it was not possible to extend a second hourly passenger service from Walsall via the Chase Line to Stafford per the base ITSS. This was due primarily to the constraints imposed by the 20mph single-ladder at Rugeley North Junction, and the lack of available platforms for Chase Line services at Rugeley Trent Valley station which prevents planning of parallel movements.

A remodelled Colwich / Rugeley North Junction option was tested where both junctions were combined with higher speed turnouts and a doubled, higher speed approach to the Chase Line via Rugeley Trent Valley. This generated sufficient flexibility to plan the additional required Chase Line services. However, this is a limited benefit derived from a potentially significant intervention. The full extent of the journey time and performance impacts associated with re-siting and remodelling Colwich Junction would require further, more detailed analysis.

In an Intermediate Markets scenario, the clear priority for long-term infrastructure enhancement was focused on the Bletchley-Milton Keynes area. Addressing this capacity bottleneck achieved more fully the objectives to prioritised established markets, and more efficiently utilised wider network capacity by improving options for interchange at Milton Keynes Central.

Utilisation of a northeast chord at Bletchley required – in this scenario – intervention in the form of fifth tracking and additional platforms between Bletchley and Milton Keynes. Much more limited utility was derived from Colwich/Rugeley North

remodelling where the initial constraint was linked primarily to additional Chase Line trains.

are laid out in detail as part of the cross-scenario prioritisation in section 6 of this report.

The train service and relative economic impact of each infrastructure option, as well as basic scope and requirements,

<i>Table 23: Infrastructure required to deliver the Intermediate Markets 'with infrastructure' train plan. Recommendations for further development can be found in Section 6 of this report.</i>	
Intermediate Markets Infrastructure Options Results	
Infrastructure Intervention	Train Service Impact
Colwich/Rugeley North Junctions Remodelling	+1tph Birmingham New Street-Stafford <i>Performance and journey time improvements through faster transit times and removal of restrictive aspect signalling.</i>
Bletchley - Milton Keynes 5th Track	+2tph Aylesbury-Milton Keynes Central +2tph Cambridge-Milton Keynes Central* <i>Potential performance improvement through relief of capacity on approach into Milton Keynes Central.</i> <i>*Passenger services from Cambridge direction would require Bletchley Northeast Chord.</i>
Milton Keynes North Connection	+2tph Aylesbury-Milton Keynes Central +2tph Cambridge-Milton Keynes Central +2tph London Euston-Milton Keynes Central <i>Unlocked sufficient platform capacity to optimise calling patterns for local services south of Milton Keynes in this scenario.</i> <i>Potential performance improvement through segregation of East West Services to and at Milton Keynes Central.</i>
Bletchley Northeast Chord	+2tph Cambridge-Milton Keynes Central <i>Additional routing option for freight. Would require Y-path with a service already in the plan on the main line due to prioritisation of capacity for passenger service</i>

Intermediate Markets: Summary and Recommendations

The testing undertaken in this scenario showed the extent to which the capacity released by HS2 could be used to serve established intermediate markets. In the released capacity train plan local services between London and Milton Keynes and freight paths via East West Rail were traded off against higher priority intercity and interregional services. This resulted in eight passenger services per hour planned via the Trent Valley lines (six intercity, and two interregional). The according quantum of trains planned to Crewe and into Manchester exceeded the assumed known available capacity at Configuration State G.

Table 24: Intermediate Markets released capacity concept train plan services planned into Crewe and Manchester.

Interface	Configuration State G current assumptions	WCSSA East-West Markets released capacity	Difference
Crewe via Stafford	5tph passenger	6tph passenger	+1tph
	5tph freight	6tph freight	+1tph
Manchester via Stoke	4tph passenger	6tph passenger	+1tph

The intercity and interregional services included in the released capacity train plan for this scenario were required to meet the scenario-specific requirements set, connecting non-HS2 intermediate locations within West Coast South route to major markets in the Northwest like Liverpool and Manchester.

The analysis undertaken in this scenario shows the need to **deliver HS2 Phase 2B Crewe-Manchester in full** and release further capacity via the Stockport corridor into Manchester. This would support serving intermediate markets more fully thereby unlocking the full potential associated with released capacity on West Coast South route.

Likewise, as in other scenarios tested, the capacity released by HS2 could be used to provide an uplift in intercity and interregional passenger services at Stoke-on-Trent, especially when providing an uplifted level of intercity and interregional-type service as a priority. While the released capacity train plan was compliant with timetable planning rules, further infrastructure enhancement would be required to assure performance and to provide further capacity for additional local services not included in the scope of this work. Network Rail's forthcoming Stoke Area Strategic Advice will build on the findings made in this report and assess the options available.

Unlocking the required local services from London and interregional services via East West Rail to Milton Keynes required – as a high priority - interventions which resolved the capacity bottleneck identified between Bletchley and Milton Keynes, and the lack of platform capacity at Milton Keynes Central. Intervention will be required at Colwich and Rugeley North junctions to provide sufficient flexibility to extend a half-hourly local service via the Chase Line. This was however, a relatively limited benefit given the potential scale of the intervention required.

Further work should be undertaken to identify the long-term options to generate capacity at Crewe and into Manchester over the long-term, assess the train service and infrastructure options available in the Stoke-on-Trent area post HS2, and provide more detail on the high priority infrastructure options identified for the route section Bletchley-Milton Keynes.

The findings of the analysis undertaken in this scenario, as well as the details of each infrastructure enhancements and their relative priority, has been captured in the cross-scenario recommendations outlined in section 6 of this report.

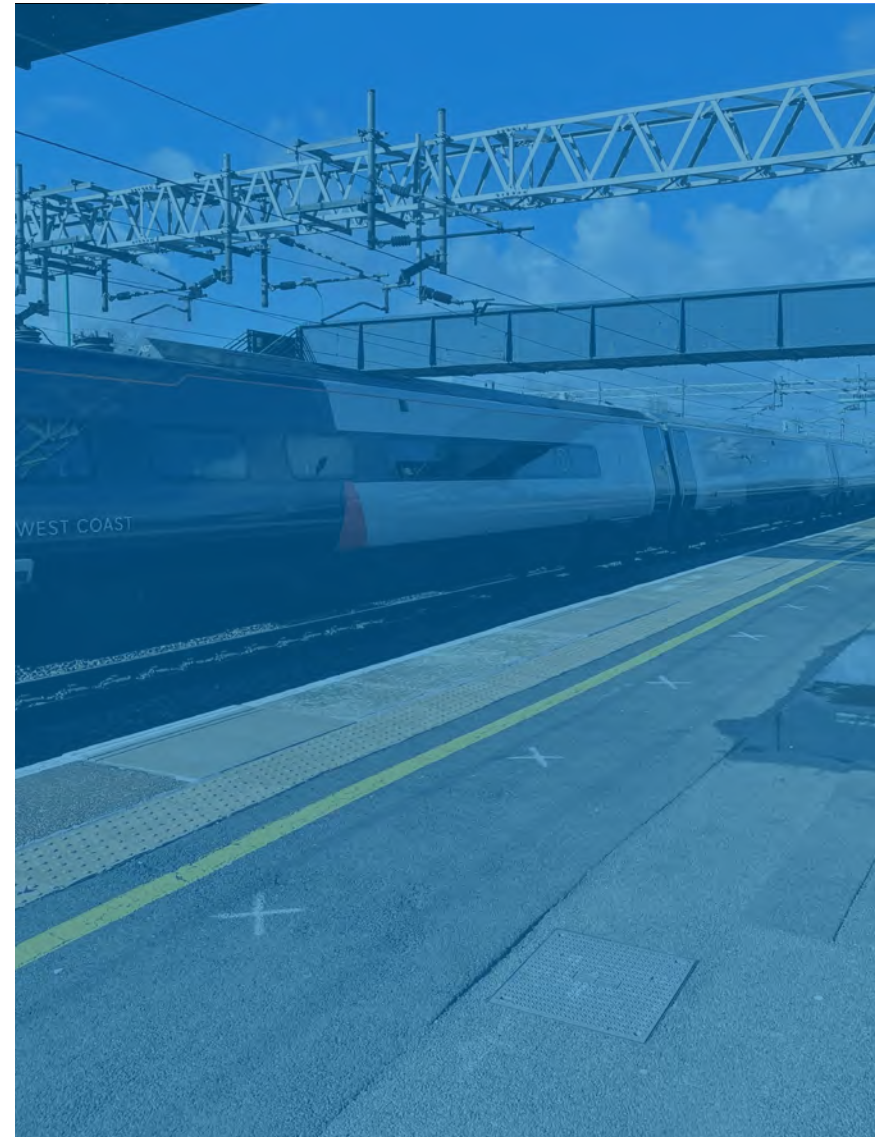

Scenario Three: East West Connectivity

Scenario Focus

Improving connectivity on an east/west axis between locations that are not frequently or directly served today.

Testing Purpose

To test what is required to distribute connectivity to a wider range of locations, planning for improved direct connections and lower generalised journey times between locations which are not frequently served today.

Determine what train service trade-offs or infrastructure is required to improve connectivity on an east/west axis, using West Coast Main Line south as a trunk route.

ITSS Guiding Objective

Train service structure targets high priority **mode shift** and **new connections** flows identified in the economic opportunity analysis.

Train Service Priorities

Prioritisation of intercity and interregional services which provide east to west connectivity, including extension of passenger and freight services via East West Rail.

Rationale

The third scenario tested in the WCSSA workstream focused on improving connectivity on an East West axis, using the capacity released by HS2 and any assumed infrastructure interventions to spread connectivity benefits to a wider set of origin and locations pairs. This represented an alternative use of capacity for passenger services when compared to the previous intermediate markets scenario which focused on established, high value revenue flows. The East West connectivity scenario instead prioritised passenger services which provided new connections between locations either not directly served today, or where existing connectivity is hampered by a low frequency of service.

Necessarily the focus of this scenario centred on bolstering rail connections which are not established markets today, and therefore do not currently generate significant revenue for the industry. Consequently, the train service structure adopted for this scenario was guided by the highest priority flows resulting from the passenger mode shift and new connections objective assessments in the economic opportunity analysis. The train services planned and prioritised in this scenario were those considered most likely to generate new trips by rail and produce the greatest increase as well as generate the greatest wider transport benefits from an improvement in generalise journey times.

Particular focus was given in this scenario to maximising the potential benefits of integration between the existing West

Coast Main Line and the planned East West Rail link between Oxford and Cambridge. The extension of passenger services and provision of freight paths from East West Rail to West Coast South route were given priority in the train planning work. Likewise, improved connections at principal Trent Valley locations (Nuneaton, Tamworth and Lichfield) were also prioritised in the requirements, reflective of the potential to stimulate those markets with improved frequencies as well as maximising the potential for interchange and onward connections at each.

The scenario-specific requirements drawn from the results of the opportunity analysis were also complemented with known train service aspirations articulated by partner organisations through the WCSSA working groups.

The assessment results showed the extent to which the capacity released by HS2 could be used to distribute connectivity benefits to a wider range of locations and stimulate new markets, as well as exploring infrastructure options which may be required to realise these outcomes more fully in the long-term.

East West Connectivity: Scenario-Specific Requirements and Base ITSS

As with all ITSSs, the minimum passenger and freight service requirements outlined in the planning principles have been included in the base East West Connectivity ITSS. A series of scenario-specific passenger service requirements have also been

set which are shown in Table 25.

The scenario-specific calls were agreed with representatives from the wider rail industry through the WCSSA working group as reflective of the scenario focus. Achieving the requirements set was of course dependent on the train planning work undertaken for this scenario. Train services which delivered the scenario-specific requirements have been prioritised in the first instance, as is the case in all scenarios tested in this work.

Per the testing methodology adopted in this work, no specific train paths were agreed before setting the scenario train service requirements. Instead, the base ITSS was constructed from first principles capturing the requirements by configuring train paths to suit. Again, this was advised by and agreed with industry partners through the established governance process for West Coast South Strategic Advice.

No additional freight requirements were set for this scenario beyond those outlined above in Planning Principle A. Requirements, trade-offs and enhancement options for freight have been explored in the freight focus scenario, though where there is potential to unlock additional freight services or routing options with and infrastructure enhancement it has been included. The full base ITSS for this scenario is attached in Appendix E.

Table 25: Scenario-specific requirements for the East West Connectivity base ITSS.

Type	tph	Origin	Destination
Limited Stop	1	Nuneaton	Manchester
			Liverpool
			Stoke-on-Trent
			Coventry
Limited Stop	1	Tamworth	Manchester
			Liverpool
			Stoke-on-Trent
			Coventry
Limited Stop	1	Lichfield	Manchester
			Liverpool
			Stoke-on-Trent
			Coventry
Limited Stop	1	Walsall	London
			Milton Keynes
			Stoke-on-Trent
Limited Stop	1	Congleton	Birmingham
			Wolverhampton
Limited Stop	1	Watford	Manchester
			Liverpool
Any Passenger	2	Oxford	Northampton
Any Passenger	2	Cambridge	Birmingham
Any Passenger	2	Aylesbury	Milton Keynes

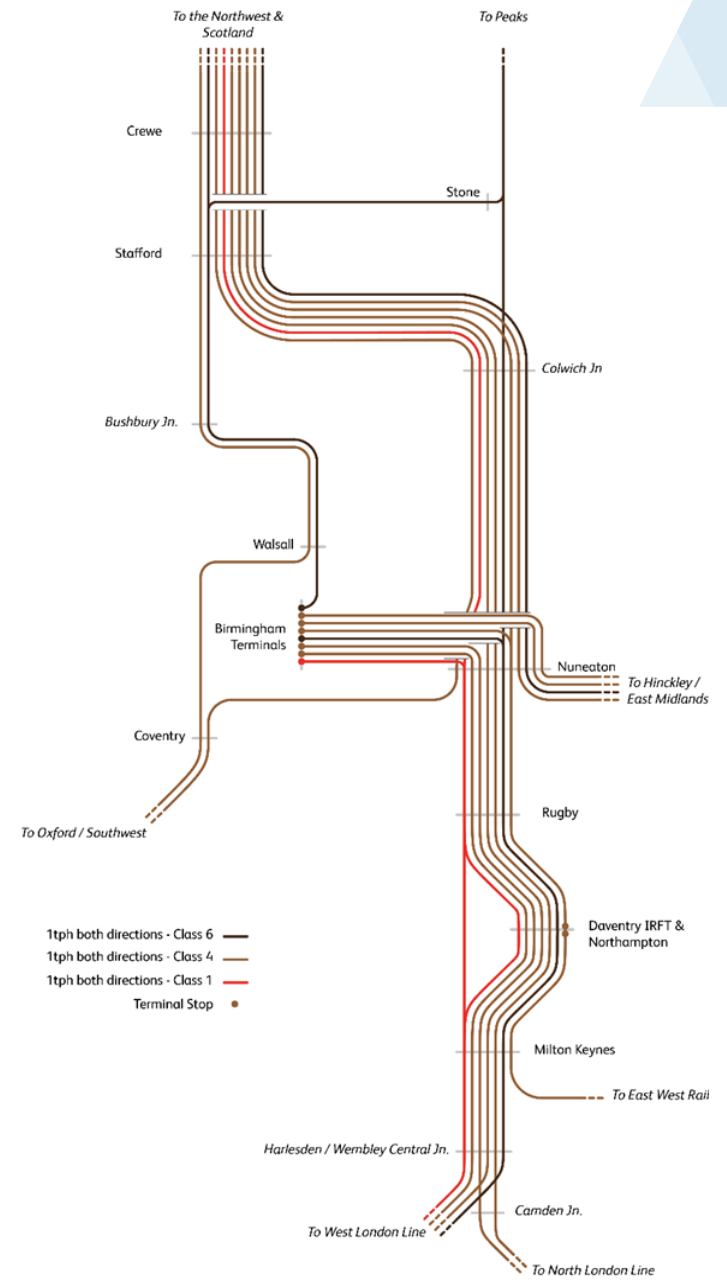
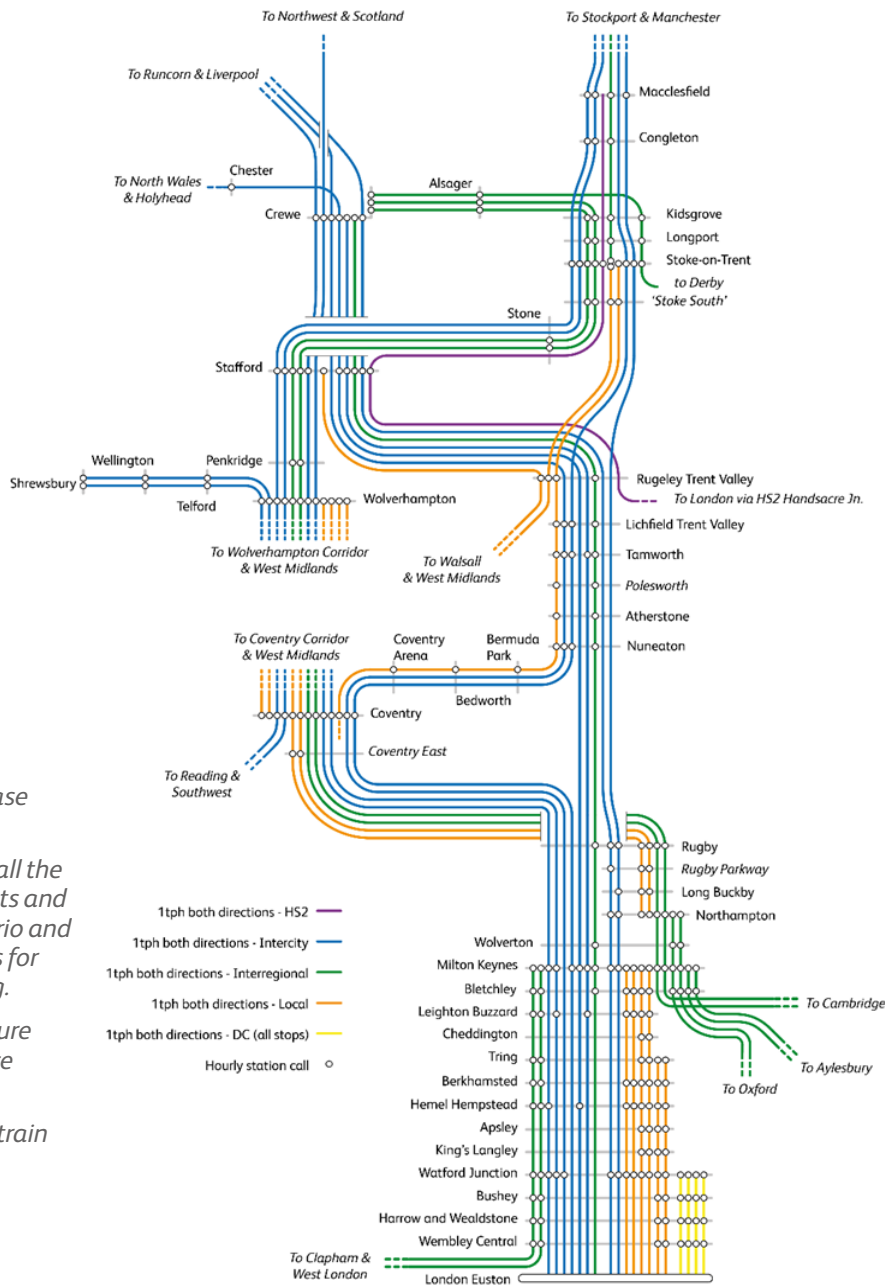

Figure 39: East West Connectivity scenario base ITSS.

The base ITSS captures all the train service requirements and objectives for this scenario and has been used as a basis for capacity analysis testing.

Passenger service structure shown left, freight service structure shown right.

One line represents one train path per hour in both directions.

East West Connectivity Released Capacity Concept Train Plan

The East West Connectivity released capacity train plan prioritised passenger services which support or generate new connectivity, with a particular focus on using the capacity released by HS2 to plan service extensions from East West Rail through Milton Keynes to Northampton and the West Midlands. The results of the multi criteria assessment reflected this target, generating the largest comparative improvement against the stimulate new markets objective when compared to the other scenarios.

Some additional calls were required in intercity-type services south of Milton Keynes – at Leighton Buzzard and Hemel Hempstead - in this scenario.. This effectively redistributed calls more evenly across all service groups, more efficiently using both fast and slow line capacity south of Milton Keynes and providing for faster direct connections between Leighton Buzzard and Hemel Hempstead, and the West Midlands and the Northwest. However, one consequence of this structure was extension of headline journey times for the longest-distance flows within the study scope, for example, between Watford and the Northwest, where intercity-type services were planned with multiple intervening calls.

It was also possible to plan intercity services between London and the Northwest via Northampton, and via Coventry and Nuneaton. Infrastructure intervention may be required at Coventry and Nuneaton to support the full 2tph service

performance-robustly alongside local aspirations. Again - when compared to the previous Intermediate Markets released capacity concept train plan - the effect here was to distribute direct connectivity to a greater range of locations at the expense of headline journey time and frequency for established markets on the trunk route. This was reflected in the results of the multi criteria assessment in which the relative improvement in the new markets objectives was greater than that observed in the previous Intermediate Markets scenario released capacity concept train plan. This was due to the priority given in the latter to intercity-type services on the trunk route which translated into a greater improvement in the revenue, economic growth and modal shift objectives instead.





However, the availability of capacity north of Milton Keynes and via the Trent Valley meant that an hourly Class 4 freight path via East West Rail could be included in the released capacity train plan, in addition to three hourly Class 4 paths from London. This was an improvement on the Intermediate Markets scenario and could be bolstered further if the second hourly Clapham Junction-Milton Keynes interregional service were substituted for a Class 1 express logistics path; something which was identified as a simple choice within the concept train planning work.

More benefit was derived in this scenario by extending services from the planned East West Rail infrastructure. While this yielded some benefits in the new markets objective, it was difficult to account for the specific impacts when modelling train services operating on a route (between Bedford and Cambridge) which is not yet in existence. Some of the benefits related to revenue and

modal shift for these services may have been underestimated due to limitations in the modelling and limited understanding of the latent demand created by East West Rail services operating from 2024. It is a recommendation of this work that further analysis quantifies in more detail the potential benefits of integrating the West Coast South and East West Rail networks fully through extended direct services as incorporated into this scenario.



Table 26: East West Connectivity released capacity train service multi-criteria assessment results.

Objective	Multi-Criteria Assessment Measure	(% Change from post-HS2 economic baseline)
	<p>Maximise Revenue Total forecasted revenue generated from passenger abstractions.</p>	<p>5.2%</p>
	<p>Supporting Development Forecasted value of time (VoT) benefits weighted for relative deprivation for each corresponding origin and destinations.</p>	<p>4.1%</p>
	<p>Encourage Modal Shift Total passenger miles abstracted from road to rail.</p>	<p>5.2%</p>
	<p>Stimulate New Markets Total value of time benefits for flows classified as new markets, either not directly connected or not frequently served.</p>	<p>28.5%</p>
	<p>Support Freight Growth Total freight marginal external costs (MEC) benefits measured by the emissions reduced through modal shift from road to rail.</p>	<p>19.9%</p>

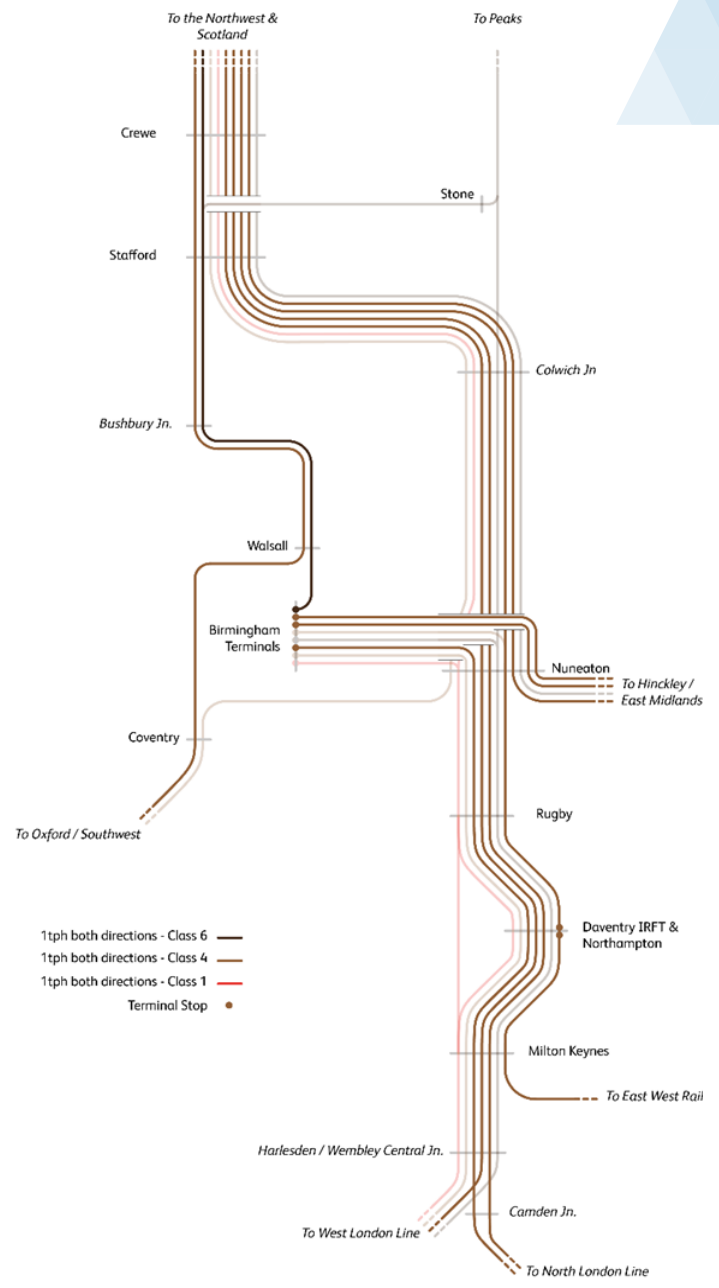
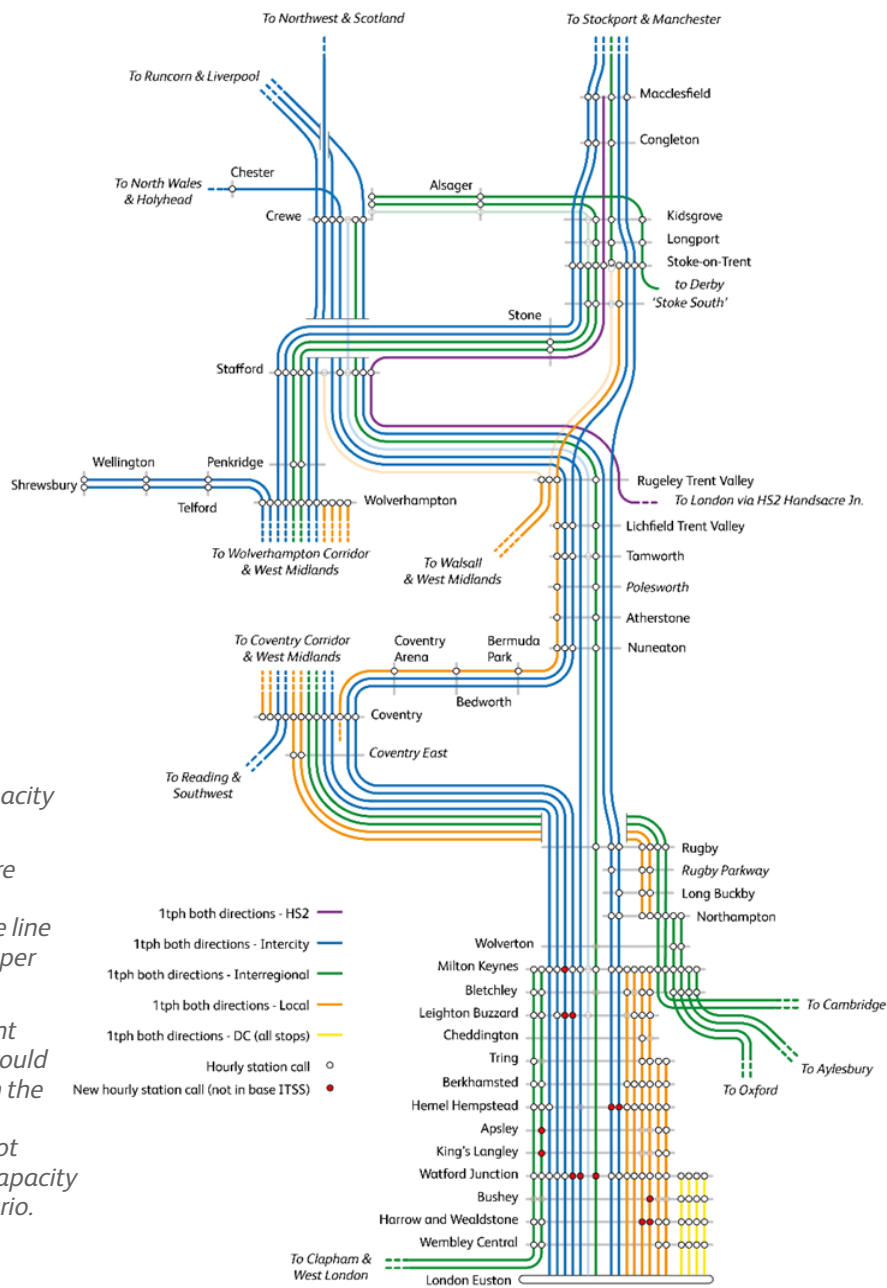

Figure 40: East West Connectivity released capacity concept train plan.

Passenger service structure shown left, freight service structure shown right. One line represents one train path per hour in both directions.

Transparent lines represent hourly train paths which could not be accommodated on the conventional network infrastructure and were not included in the released capacity train service for this scenario.

- 1tph both directions - HS2
- 1tph both directions - Intercity
- 1tph both directions - Interregional
- 1tph both directions - Local
- 1tph both directions - DC (all stops)
- Hourly station call
- New hourly station call (not in base ITSS)

- 1tph both directions - Class 6
- 1tph both directions - Class 4
- 1tph both directions - Class 1
- Terminal Stop

The Generalised Journey Times recorded in the East West Connectivity scenario were transformative for locations within the scope of the study when compared to the December 2022 timetable. This, as in all scenarios tested in this work, was driven primarily by the improvements in frequency achievable for locations within West Coast South route, and the consequent reduction in interchange penalties for most locations across the route.

However, these improvements were more uneven than those observed in previous scenarios, with much more significant improvement focused on a smaller number of origin/destination pairs. This was primarily a consequence of prioritising services which call at a greater range of locations rather than raising the quantum of limited-stop intercity-type paths. For example, GJTs between Milton Keynes and locations furthest away within the study scope (Stoke-on-Trent, Manchester and Liverpool) did not significantly improve or were longer than those observed in the December 2022 timetable.

The focus of the scenario in widening connectivity and prioritising new markets resulted in some significant reductions in GJT for currently unserved or underserved markets. This included a range of flows to and from both Coventry and Northampton, driven by the priority given to intercity-type services at both which did not feature in previous scenarios. In this scenario the track capacity made available by HS2 could be used to create significant improvements in connectivity for flows which are not currently well served by rail instead.

The most transformative change in GJTs was observed for locations served directly by the East West Rail route, notably for flows to and from Cambridge or Bedford. For the purposes of the GJT assessment a direct connection was assumed (which would require additional infrastructure at Bletchley), but the results demonstrated the extent to which the capacity released by HS2 could be used to radically improve connectivity through fuller integration of the East West Rail and West Coast South networks. The figures shown in Table 27 are comparative to the December 2022 timetable as a baseline. Some significant improvement for these flows will be achievable in the interim as East West Rail enters into service in stages from 2024 (per those outlined in the assumptions previously in this report).

Further, as explained in the next section – extension of more than 2tph East West Rail services from Bletchley acutely impacted the capability of the existing infrastructure by raising the capacity utilisation rate into Milton Keynes Central. This was an issue in all scenarios to some extent, but was fundamentally exacerbated in this scenario by prioritising East West Rail services in the train planning and increasing the number of conflicting moves at Bletchley. The potential benefits associated in expanding connectivity utilising released capacity must be weighed against the impact on capacity utilisation, especially at points on the network which may need to operate differently or accommodate a more intense service.

Table 27: East West Connectivity released capacity train service key generalised journey times..

Origin	Destination	GJT vs Dec'22 (minutes)
Major Improvements		
Cambridge	Northampton	-183
	Milton Keynes	-176
	Coventry	-92
	Birmingham	-18
Coventry	Lichfield	-36
	Manchester	-26
	Tamworth	-26
	Stoke-on-Trent	-17
Northampton	Manchester	-48
	Stoke-on-Trent	-39
	Lichfield	-22
	Tamworth	-21
Hemel Hempstead	Liverpool	-55
	Manchester	-50
	Tamworth	-27
	Birmingham	-26
Significant Disbenefits		
Stoke-on-Trent	London	+40
Milton Keynes	Liverpool	+42
	Manchester	+16
Nuneaton	Manchester	+16

East West Connectivity Network Constraints

As in all scenarios tested, the need to plan freight and passenger services created a difference in speed profiles which had singular impact on capacity, especially on the West Coast South slow lines where the ruling headway is four-minutes. Extending passenger services from East West Rail to Northampton and through to Birmingham exacerbated this issue through Northampton where capacity was quickly used up.

However, fewer intercity and interregional passenger services were required when compared to the Intermediate Markets scenario. This meant that there was sufficient opportunity to plan transitional moves between the fast and the slow lines between London and Milton Keynes, freeing slow line capacity for the requisite quantum of local passenger service. As in previous scenarios, constraints elsewhere – notably between Bletchley and Milton Keynes – represented more immediate issues which would only be exacerbated should a reduction in slow line headway be achieved through re-signalling or ETCS roll out.

Bletchley to Milton Keynes

The route section between Bletchley and Milton Keynes again represented a significant point of constraint in the East West Connectivity scenario. While all but one intercity passenger path could be accommodated at Milton Keynes in the released capacity train plan, it should be noted that the rate of capacity utilisation from Bletchley into Milton Keynes Central was over

90% which would represent an unpalatable risk to performance. This also left no capacity for any additional freight beyond the single hourly Class 4 path from East West Rail, despite the possibility of routing additional freight via the Weedon fast lines and through the Trent Valley.

The results of this scenario test showed that passenger services could be extended from East West Rail without infrastructure intervention on the conventional network, but that this drove a trade-off in the quantum of intercity-type services planned through Milton Keynes and imported a significant risk to performance through high capacity utilisation locally.

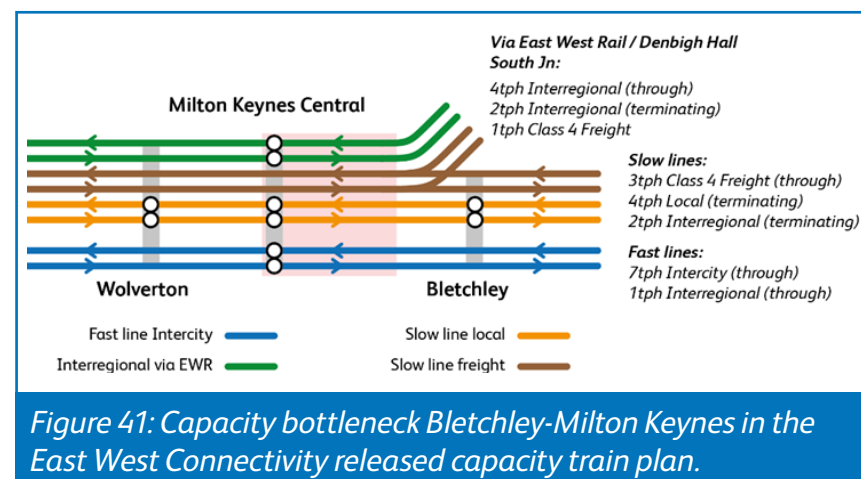

Coventry

The routing of intercity-type services in this scenario provided direct connectivity between Coventry, Nuneaton and the Northwest via the Trent Valley as well as an even interval 4tph intercity-type service between Coventry and London. This was found to be compliant within the scope of the West Coast South Strategic Advice work but would leave no residual capacity for local service improvements at Coventry station as well as a significant risk to performance by introducing additional crossing movements through the station itself.

The primary constraint relates to the sup-optimal layout of track, switches and crossings at Coventry. The existing infrastructure

pairs platforms by direction with west-bound movements through platforms 1 and 2, and east-bound movements through platforms 3 and 4. This has the general effect of importing a large number of crossing moves if additional services are planned from the Leamington or Rugby directions through to Nuneaton via Bedworth.

The sub-optimal track layout at Coventry is compounded by restrictive signalling arrangements which prevent a departure from platform 1 simultaneous to an arrival into platform 2. To achieve a reliable, even interval 4tph intercity service between Coventry and London the track layout and platforming at Coventry will need to be addressed.

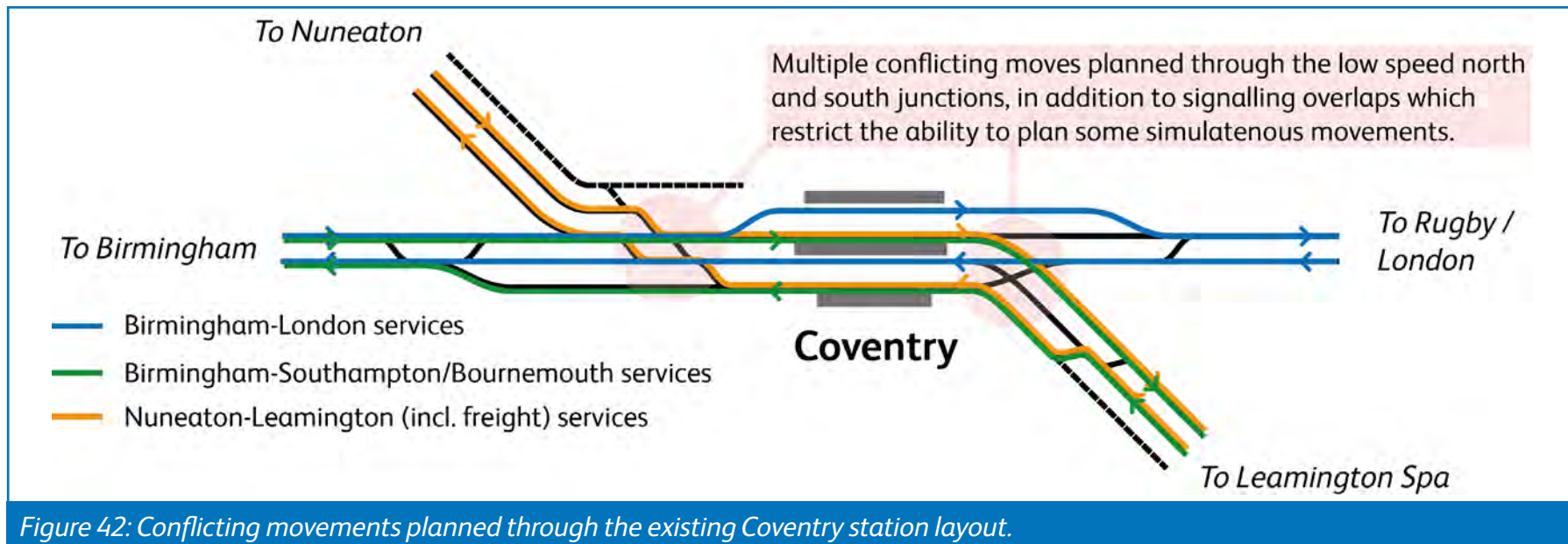

Nuneaton

In the released capacity train plan all intercity type services could be compliantly planned through Nuneaton, including those from the Coventry direction. However, as was the case at Coventry, Nuneaton may present a significant constraint when assuming an uplift in local services via the Bedworth lines.

A key issue at Nuneaton is the length of platform 1 which is insufficient to accommodate intercity-type rolling stock, and forces movements in both directions to be planned via Platform 2, limiting capacity and capability in times of perturbation. Further, the approach into platforms 1 and 2 from the West Coast Main Line is planned through Ashby Junction which is a 20mph single ladder a mile to the north of Nuneaton Station. Again, this restricts capacity and planning flexibility by imposing a lengthy crossing move across all four West Coast South main lines for a southbound train to Coventry.

While the released capacity train plan was found to be compliant with the existing timetable planning rules, Nuneaton must be considered a point of constraint requiring further investigation if intercity-type services are planned via the Bedworth lines in future.

Colwich and Rugeley North Junctions

The base ITSS for this scenario specified an uplifted passenger service via the Chase Line from Walsall to Stafford and Stoke-on-Trent. These services could not be accommodated alongside the specified services from the Trent Valley on the existing infrastructure at Rugeley and Colwich Junctions. This was driven primarily by the inability to plan a parallel

move for both north and south-bound services off the Chase Line, as well as the consequent impact on the existing flat-diamond crossing at Colwich Junction. The low transit speeds through the existing Colwich Junction could accommodate the seven passenger and four freight paths per hour in the released capacity train plan, but any uplift from the Chase Line beyond this would require change to the local infrastructure.

Stoke-on-Trent Area

The capacity released by HS2 provided the opportunity to uplift the level of passenger service through Stoke-on-Trent. This resulted in a released capacity train plan which, while compliant with timetable planning rules, forced some services to terminate on running lines or undertake an empty coaching stoke movement into a local siding.

As in the Intermediate Markets scenario it is highly unlikely that the services planned as part of the WCSSA train plans at Stoke could be accommodated alongside any additional local aspirations not captured in the scope of this work. Again, the single track section at Alsager represented an immediate constraint limiting the ability for released capacity services to terminate in the bay platforms at Crewe.

A more geographically focused strategic assessment is required for the Stoke-on-Trent area, capturing train service and infrastructure options which use the outputs from this workstream as a base. The requirement for this further study has been captured in the recommendations and next steps in sections 6 and 7 respectively.

East West Connectivity: ‘With Infrastructure’ Concept Train Plan

Track capacity constraints between Bletchley and Milton Keynes in this scenario resulted from the priority given to extending passenger services via East West Rail. While the required services could be accommodated utilising the capacity released by HS2 and no additional conventional network infrastructure, the very high rate of capacity utilisation in this area limited flexibility and posed a significant performance risk. Provision of additional track from Bletchley and new platforms at Milton Keynes reduced the capacity utilisation rate helping to protect both capability and performance by segregating traffic from the East West Rail route and on the slow lines on the West Coast Main Line into Milton Keynes.

Critically, provision of a through connection from assumed new platforms at Milton Keynes Central to the main lines immediately north of the station maximised the effect of the intervention, effectively segregating all East West Rail services beyond Milton Keynes and vacating them from the existing platforms. The consequent release of platform capacity resulted in a significant reduction of the local capacity utilisation rate and offered improved flexibility for local and interregional services (6tph) from London terminating at Milton Keynes. This additional flexibility also meant freight paths could be planned through Milton Keynes and via the Weedon fast lines, freeing up capacity on the slow line route via Northampton for two additional Class 4 paths in total. This is reflected in the comparative improvement in the freight objective

assessment result in shown Table 28. The capacity generated on the Northampton slow lines could be used alternatively for additional passenger services which were not included in the base ITSS for this scenario should this be a priority.





Infrastructure intervention at Colwich and Rugeley North Junctions was required to extend Chase Line trains from Walsall on to the West Coast South lines. This generated some additional change in the multi criteria assessment because of the additional direct connections for Stafford, though – as in other scenarios tested - this is likely to be a minimal benefit in comparison to the scale of the intervention tested in this work. Further development could package or split out elements of this intervention to reduce overall cost.

Table 28: East West Connectivity 'with infrastructure' train service multi-criteria assessment results.

East West Connectivity 'with infrastructure' concept train plan results (all results relative to East West Connectivity released capacity train plan)

Service Changes

- +1tph Class 4 freight Felixstowe - Daventry
- +1tph Class 4 freight London - Crewe
- +1tph Suburban Walsall - Stafford

Objective	Multi-Criteria Assessment Measure	Additional % vs released capacity
	<p>Maximise Revenue</p> <p>Total forecasted revenue generated from passenger abstractions.</p>	+0.5%
	<p>Supporting Development</p> <p>Forecasted value of time (VoT) benefits weighted for relative deprivation for each corresponding origin and destinations.</p>	+1.7%
	<p>Encourage Modal Shift</p> <p>Total passenger miles abstracted from road to rail.</p>	+0.6%
	<p>Stimulate New Markets</p> <p>Total value of time benefits for flows classified as new markets, either not directly connected or not frequently served.</p>	+1.2%
	<p>Support Freight Growth</p> <p>Total freight marginal external costs (MEC) benefits measured by the emissions reduced through modal shift from road to rail.</p>	+27.0%

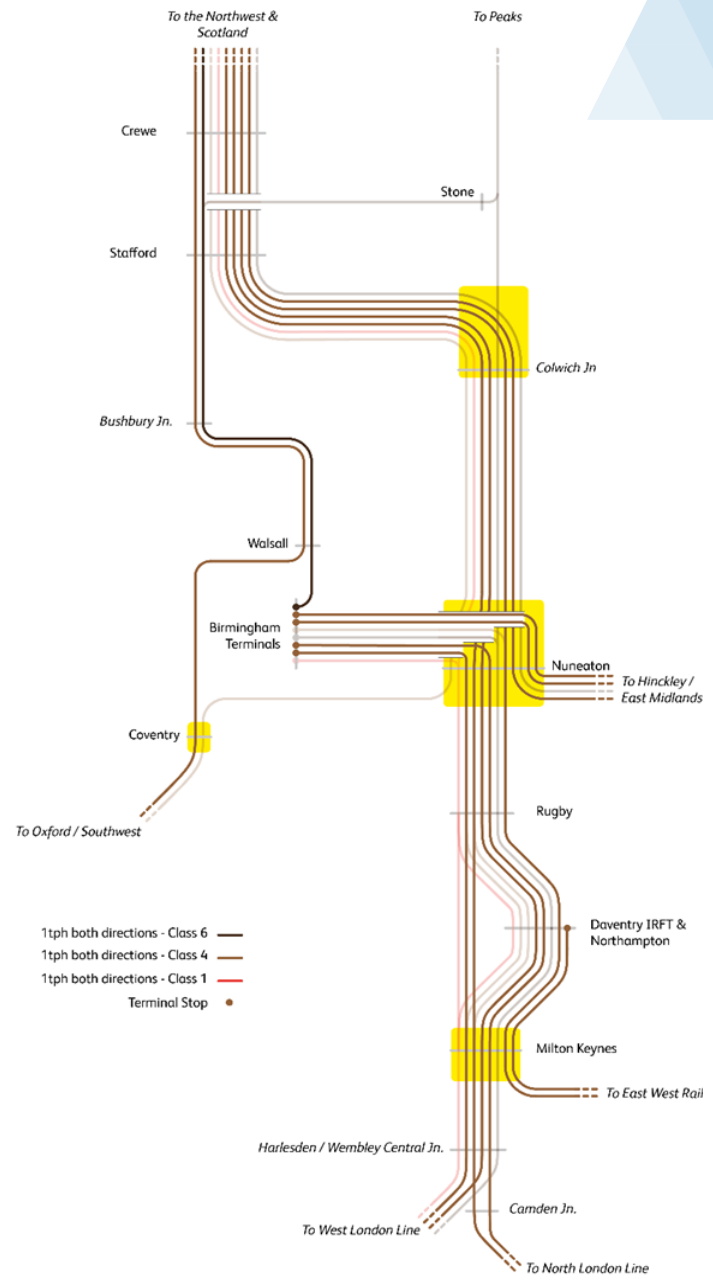
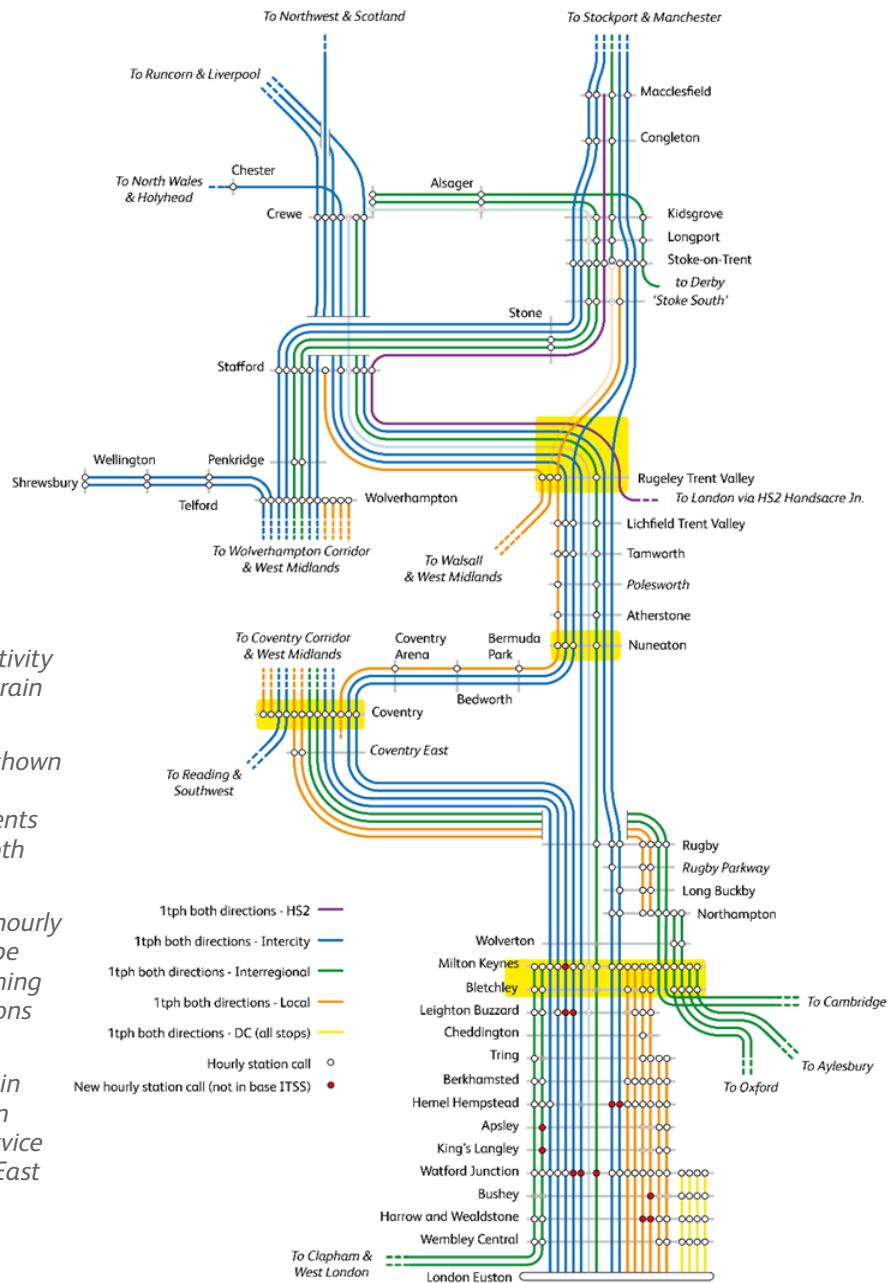

Figure 43: East West Connectivity with infrastructure concept train plan.

Passenger service structure shown left, freight service structure shown right. One line represents one train path per hour in both directions.

Transparent lines represent hourly train paths which could not be accommodated when assuming the infrastructure interventions identified.

Infrastructure requirements in this scenario were focused on providing new passenger service connections and extending East West Rail services through Bletchley.

- 1tph both directions - HS2
- 1tph both directions - Intercity
- 1tph both directions - Interregional
- 1tph both directions - Local
- 1tph both directions - DC (all stops)
- Hourly station call
- New hourly station call (not in base ITSS)

- 1tph both directions - Class 6
- 1tph both directions - Class 4
- 1tph both directions - Class 1
- Terminal Stop

The infrastructure options that were tested in this scenario are shown in Table 29. Resolution of the Bletchley to Milton Keynes capacity bottleneck was an immediate priority. Fifth and sixth track options which assumed new bay platforms at Milton Keynes central had limited impact on the train plan compared to other scenarios given that only two of the six hourly passenger services planned from East West Rail terminated at Milton Keynes and could therefore be moved into the new platforms. This released some platform capacity at Milton Keynes Central, generating a potentially positive performance impact, but did not permit any additional passenger or freight services beyond those included in the released capacity concept train plan. The results of the scenario demonstrated that a northeast chord at Bletchley could be utilised without additional infrastructure between Bletchley and Milton Keynes. This required use of the capacity released by HS2 to extend East West Rail services on to the mainline, limiting the capacity available for intercity-type services on the trunk route, as well as importing a significant potential performance impact. Accordingly, it is recommended that full utilisation of a chord at Bletchley should be explored alongside additional infrastructure between Bletchley and Milton Keynes, mitigating from the outset the impact that integrating the East West Rail and West Coast South networks will have on capacity and performance on the trunk main line.

Fully addressing the capacity constraint at Milton Keynes in this scenario required additional through platforms instead of bays. This allowed all East West Rail services (six hourly passenger services and one Class 4 freight service) to be planned entirely

apart from West Coast Main Line services up to and through Milton Keynes Central, the general effect of which was to relieve capacity utilisation on the existing infrastructure. However, this option also provided sufficient planning flexibility, in this scenario, for two additional hourly Class 4 freight services (one via London and one via East West Rail) which could be timed through Milton Keynes Central and on to the fast lines via Weedon (bypassing the heavily constrained Northampton slow lines). As in the Freight-Focused scenario, this was only achievable due to the lower quantum of conventional intercity-type services routed via the Weedon fast lines (6tph) when compared to the Intermediate Markets scenario (10tph). Priority was also given in this scenario to intercity-type services via Coventry and Nuneaton, as well as local service extensions from Walsall via the Chase Line. In both instances, planning these train services drove constraints which were not encountered in the previous freight and intermediate markets scenarios.

At Coventry, remodelling of the layout will be required to accommodate the additional intercity services on top of local services in the West Midlands. An enhancement option has been identified which involves rationalising the approaches to all platforms, removal of existing signalling restrictions and a more uniform speed profile for transitory moves across the station between Leamington and Nuneaton. The scope and specification for this option is laid out in more detail in section 7 of this report, however a key requirement for this intervention was provision of the normal route for services from West Coast

South through platforms 1 and 2 (rather than through platforms 1 and 3 as today). While this represents a significant intervention it would generate sufficient planning flexibility to provide a broadly even interval, 15-minute intercity-type service between Coventry and London, as well as support direct services from Coventry to the Northwest via the Trent Valley lines.

These services are also likely to require intervention at Nuneaton, namely the extension of platform 1 to a sufficient length to accommodate intercity-type rolling stock, as well as relocation and remodelling of Ashby Junction to provide faster transit and parallel movements from the West Coast Main Line to and from the Bedworth lines. Again, the specific scope and requirements for this option are captured in section 6 of this report.

A key finding in all scenarios tested in this work was the difficulty of extending Chase Line services from Walsall to Stafford or Stoke-on-Trent, even when using the capacity released by HS2. This is due primarily to constraints imposed by the slow speed, single ladder at Rugeley North Junction, as well as the single platform available for Chase Line services at Rugeley Trent Valley. In this scenario, the extension of two hourly passenger services per hour from Walsall to Stafford required doubling Rugeley North Junction and provision of an additional Chase Line platform at Rugeley Trent Valley. This provided flexibility for parallel moves from the Chase Line as well as minimising the impact of movements across the West Coast Main Line.

As in previous scenarios, this enhancement is likely to place more pressure at the existing Colwich Junction and so a single option

to re-site and combine Colwich and Rugeley North Junctions was assumed. Interventions at Rugeley could be progressed separately to limit the cost, though further detailed work would be required and it is recommended that passive provision to re-site Colwich Junction immediately north of Rugeley Trent Valley is provided as a minimum.

All infrastructure enhancement options, including scope, requirements, and cross-scenario impacts have been captured in the recommendations in section 6 of this report.

Table 29: Infrastructure required to deliver the East West Connectivity 'with infrastructure' train plan.

East-West Markets Infrastructure Options Results

Infrastructure Intervention	Train Service Impact
Colwich/Rugeley North Junctions Remodelling	+1tph Birmingham New Street-Stafford (via Chase Line) +1tph Birmingham New Street-Stoke (via Chase Line) <i>Performance and journey time improvements through faster transit times and removal of restrictive aspect signalling.</i>
Nuneaton Remodelling	<i>Required to ensure sufficient planning flexibility and performance for +2tph London-Liverpool/Manchester (via Coventry and Nuneaton)</i> <i>Improved flexibility and performance for hourly Class 4 freight movements to and from West Coast Main Line.</i>
Coventry Remodelling	<i>Required to ensure sufficient planning flexibility and performance for +2tph London-Liverpool/Manchester (via Coventry and Nuneaton)</i> <i>Improved layout provides for potentially 15-minute interval for Coventry-London intercity-type services.</i>
Bletchley - Milton Keynes 6th Track	<i>Performance / Resilience improvement through some released capacity at MKC station.</i>
Milton Keynes North Connection	+1tph Class 4 Freight Felixstowe/East England-Crewe/Northwest +1tph Class 4 London-Daventry <i>Significantly improved performance and planning flexibility through released capacity at MKC station which permitted Class 4 freight routed via Weedon fast lines.</i>
Bletchley Northeast Chord	+2tph Cambridge-Milton Keynes Central <i>Additional routing option for freight. Would require Y-path with a service already in the plan on the main line due to prioritisation of capacity for passenger service</i>

East West Connectivity: Summary and Recommendations

The analysis undertaken in this scenario showed the extent to which the capacity released by HS2 could be used to distribute improvements in passenger service connectivity more widely and support greater integration of the West Coast South and East West Rail networks.

As in all other scenarios tested in this work, the requirement to serve intermediate markets into the Northwest meant the quantum of trains planned to Crewe and into Manchester exceeded the assumed known available capacity at Configuration State G:

Table 30: East West Connectivity released capacity concept train plan services planned into Crewe and Manchester.

Interface	Configuration State G current assumptions	WCSSA East-West Markets released capacity	Difference
Crewe via Stafford	5tph passenger	6tph passenger	+1tph
	5tph freight	6tph freight	+1tph
Manchester via Stoke	4tph passenger	5tph passenger	+1tph

The enhancement options tested between Bletchley and Milton Keynes (assuming the Northern Connection option) could generate sufficient capacity for an additional hourly Class 4

freight path to Crewe which would be in addition to the quanta described above.

The analysis undertaken here demonstrates further the need to **deliver HS2 Phase 2B Crewe-Manchester in full** or release additional capacity into Manchester via Crewe or Stockport to fully achieve the objectives set for the East West Connectivity scenario.

Likewise, the capacity released by HS2 could also be used to provide an uplift in intercity and interregional passenger services at Stoke-on-Trent. However, further infrastructure enhancement would be required to both fully assure performance and to provide sufficient capacity for additional local services not included in the scope of this work. Network Rail's forthcoming Stoke Area Strategic Advice will build on the findings made in this report and assess the train service and infrastructure options available.

The immediate priority for infrastructure intervention in this scenario was the Bletchley-Milton Keynes area, with most utility generated by a 'northern connection' option which segregated East West Rail services fully at Milton Keynes Central by providing new through platforms. While a northeast chord at Bletchley could be utilised with no further intervention it would represent a threat to performance and so it is recommended these options are explored as a package.



Intervention was required at Colwich and Rugeley North junctions to provide sufficient flexibility to extend local services via the Chase Line. This was however, a relatively limited benefit given the potential scale of the intervention required.

Likewise, remodelling at Coventry and Nuneaton – based on the options identified in this work – must be explored further, incorporating aspirations for local service improvements if the operation of intercity-type services from London via the Bedworth lines is a priority.

Further work is required to assess the long-term options to provide sufficient capacity to serve intermediate markets in the Northwest, the options available to support local service aspirations in the Stoke-on-Trent area, and provide more detailed analysis of the infrastructure options identified between Bletchley and Milton Keynes.

The findings of the analysis undertaken in this scenario, as well as the details of each infrastructure enhancements and their relative priority, has been captured in the cross-scenario recommendations outlined in section 6 of this report.

Scenario Four: New Connections

Scenario Focus

Improving connectivity between locations that aren't directly or frequently served today and prioritising new stations proposals.

Testing Purpose

To test what is required to distribute connectivity to a wider range of locations and the cumulative, whole-system impact of serving a wide range of new stations.

Determine what train service trade-offs or infrastructure is required to support new connections and provide an appropriate service at an expanded number of new stations.

ITSS Guiding Objective

Train service structure targets high priority **mode shift** and **new connections** flows, as well providing a minimum 2tph service at new stations.

Train Service Priorities

Prioritisation of passenger services which provide connectivity for new or underserved markets and passenger services which call at new stations.

Rationale

The fourth scenario tested in the WCSSA workstream adopted a similar focus to the third scenario in stimulating and supporting new markets, whilst also including a wider range of new stations proposals. The rationale of undertaking this scenario test was to assess the extent to which the capacity released by HS2 could be used to prioritise serving new stations, as well as identify the trade-offs inherent in using capacity to serve new stations in potentially challenging locations.

This scenario has also provided an assessment wider network constraints imposed by the focus on new stations, as well as credible infrastructure options to relieve them. These have been focused on the priorities for this scenario as well as protect the minimum passenger service requirements set for every scenario. The train planning activity undertaken for this scenario prioritised passenger services which called at assumed new stations in the base ITSS which have not been tested in other scenarios, including South Northampton, Daventry, Brinsford and Meecebrook. The new stations that have been incorporated into all previous scenario ITSSs (namely Rugby Parkway, Coventry East, Polesworth and Stoke South) were also ascribed a service uplift beyond the minimum requirements where appropriate. The approach and rationale applied to testing new stations proposals is provided in more detail in Planning Principle H and associated recommendations can be found in section 7.4 of this report.

As in all scenarios, the scenario-specific requirements drawn from the results of the opportunity analysis were also reviewed by industry partners, with appropriate train service aspirations incorporated into the base ITSS too.

New Connections: Scenario-Specific Requirements and Base ITSS

As with all ITSSs tested in this work, the minimum passenger and freight service requirements outlined in the planning principles have been included in the base New Connections ITSS. A series of scenario-specific passenger service requirements have also been set for the intermediate markets scenario, shown in Table 31.

The scenario-specific requirements were agreed with the wider rail industry through the West Coast South Strategic Advice working group, reflective of the purpose of the scenario to identify opportunities and requirements to expand connectivity and prioritise service of new stations. Assumed locations for each of the new stations tested – both those included in all scenarios and those specific to this scenario - can be found above in Planning Principle H. This work has not evaluated the business case or quantified benefits for any new stations proposals, but has instead focused on the wider impact on network capacity and the capability of the infrastructure more broadly to accommodate them as part of a future train service specification, post-HS2.

Per the testing methodology adopted in this work, no specific train paths were agreed before setting the scenario train service requirements. Instead, the base ITSS was constructed from first principles capturing the requirements by configuring train paths to suit. Again, this was advised by and agreed with industry partners through the established governance process for West Coast South Strategic Advice.

No additional freight requirements were set for this scenario beyond those outlined above in Planning Principle A. Requirements, trade-offs and enhancement options for freight have been explored in the previous scenario. The full base ITSS for this scenario is attached in Appendix F.

Table 31: Scenario-specific requirements for the New Connections Base ITSS.

Type	tph	Origin	Destination
Limited Stop	1	Nuneaton	Manchester
			Liverpool
			Stoke-on-Trent
			Coventry
Limited Stop	1	Tamworth	Manchester
			Liverpool
			Stoke-on-Trent
			Coventry
Limited Stop	1	Lichfield	Manchester
			Liverpool
			Stoke-on-Trent
			Coventry
Limited Stop	1	Walsall	London
			Milton Keynes
			Stoke-on-Trent
Limited Stop	1	Congleton	Birmingham
			Wolverhampton
Limited Stop	1	Watford	Manchester
			Liverpool
Limited Stop	2	Services call at 'South Northampton' new station	
Limited Stop	2	Services call at 'Daventry' new station	
Limited Stop	2	Services call at 'Brinsford' new station	
Any Passenger	2	Services call at 'Meecebrook' new station	

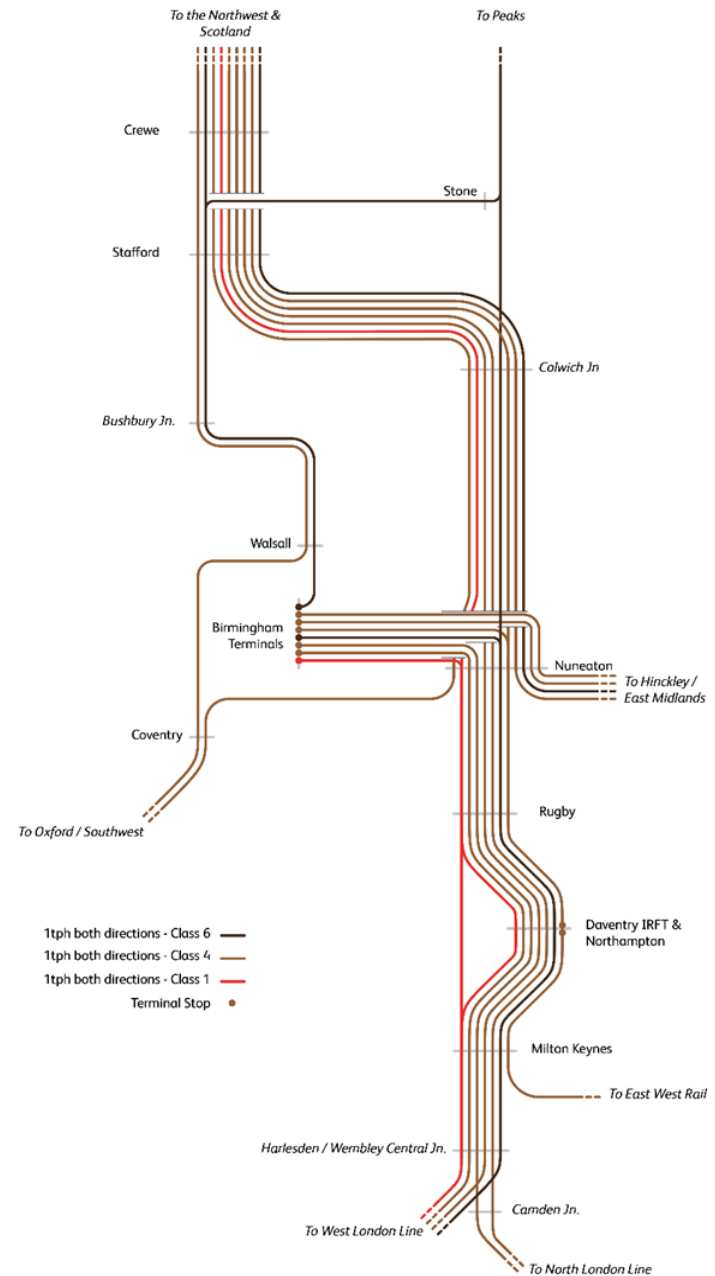
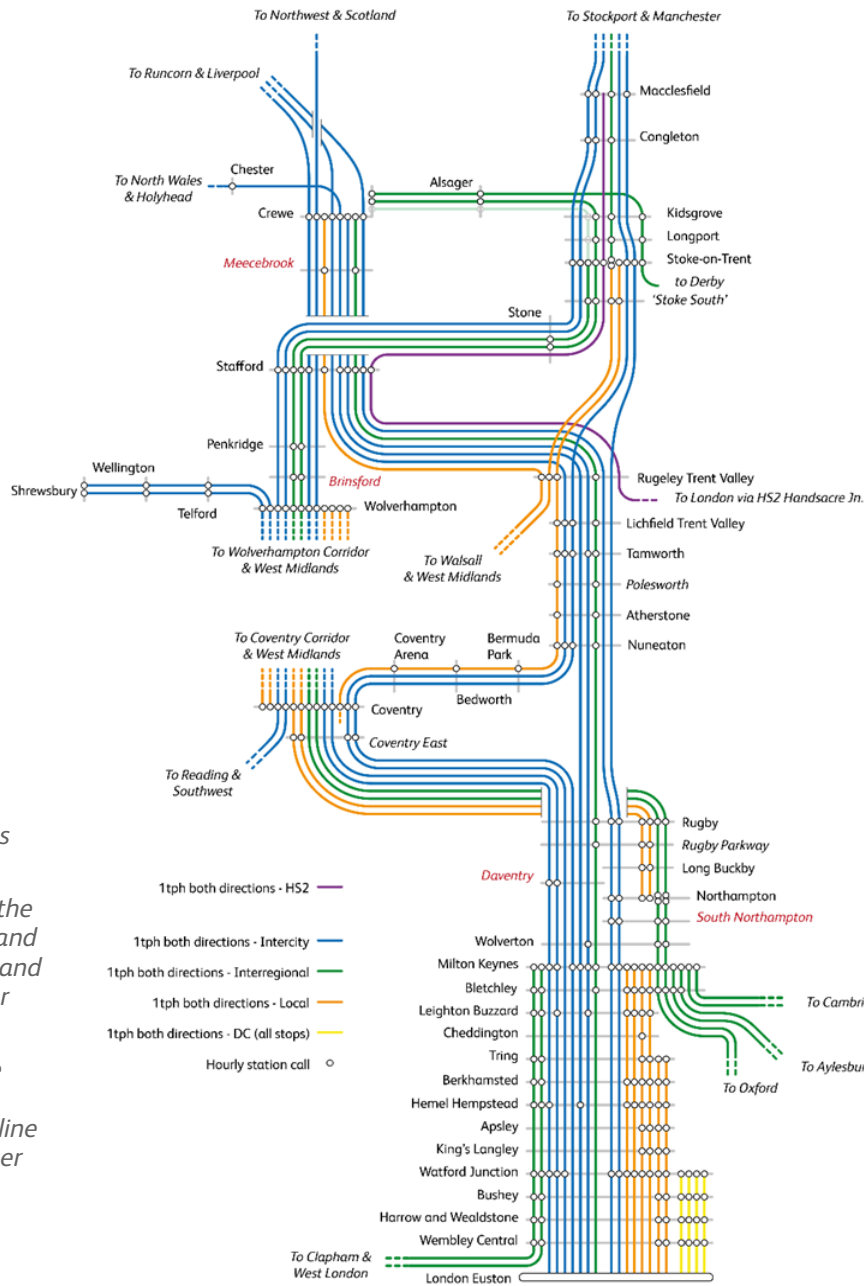

Figure 44: New Connections scenario base ITSS.

The base ITSS captures all the train service requirements and objectives for this scenario and has been used as a basis for capacity analysis testing.

Passenger service structure shown left, freight service structure shown right. One line represents one train path per hour in both directions.

New Connections: Released Capacity Concept Train Plan

The released capacity concept train plan for the New Connections scenario provided a similar structure for passenger services between London and Milton Keynes when compared to the previous East West Connectivity scenario. However, the inclusion of all new stations calls required additional capacity, driving a trade-off in both the quantum of service which could be accommodated on the existing infrastructure as well as compromising headline journey times which needed to incorporate displaced stations calls as a consequence.





The inclusion of new stations at Daventry and South Northampton significantly reduced capacity and exacerbated the already heavily constrained Bletchley-Milton Keynes bottleneck. Not all services could be timed through Milton Keynes Central and then call in a pattern optimised for capacity at South Northampton, Northampton, Long Buckby and Rugby Parkway. These additional station calls and the need to retain four hourly Class 4 freight paths meant that only one of the two East West Rail services from Oxford-Northampton could be planned beyond Milton Keynes Central. Likewise, the additional station calls required greater flexibility at Milton Keynes, reducing available platform capacity and limiting the Clapham Junction-Milton Keynes service to 1tph.

The constraints imposed by the South Northampton calls specifically also meant that intercity-type services through the slow lines had to be paired with limited stop services from

the West Midlands. This resulted in provision of no direct connectivity from Northampton to the Northwest, as specified in the base ITSS and achieved in the East West Connectivity scenario concept train plans (as described in the previous section).

These outcomes are reflected in the results of the multi criteria assessment. Though there was some improvement on the baseline in this scenario – as shown in Table 32 - it was a comparatively smaller improvement than that observed in the previous passenger-focused scenarios across all objectives. The range of new stations generated a system-wide impact by reducing capacity for service improvements elsewhere which must be weighed against any specific transport benefits derived from the new stations themselves, should they be developed further. Consequently, it is recommended that a holistic stations assessment is undertaken for the Northamptonshire area before further development.

Table 32: New Connections released capacity train service multi-criteria assessment results.

Objective	Multi-Criteria Assessment Measure	(% Change from post-HS2 economic baseline)
	<p>Maximise Revenue Total forecasted revenue generated from passenger abstractions.</p>	<p>5.0%</p>
	<p>Supporting Development Forecasted value of time (VoT) benefits weighted for relative deprivation for each corresponding origin and destinations.</p>	<p>2.9%</p>
	<p>Encourage Modal Shift Total passenger miles abstracted from road to rail.</p>	<p>5.2%</p>
	<p>Stimulate New Markets Total value of time benefits for flows classified as new markets, either not directly connected or not frequently served.</p>	<p>28.5%</p>
	<p>Support Freight Growth Total freight marginal external costs (MEC) benefits measured by the emissions reduced through modal shift from road to rail.</p>	<p>19.9%</p>

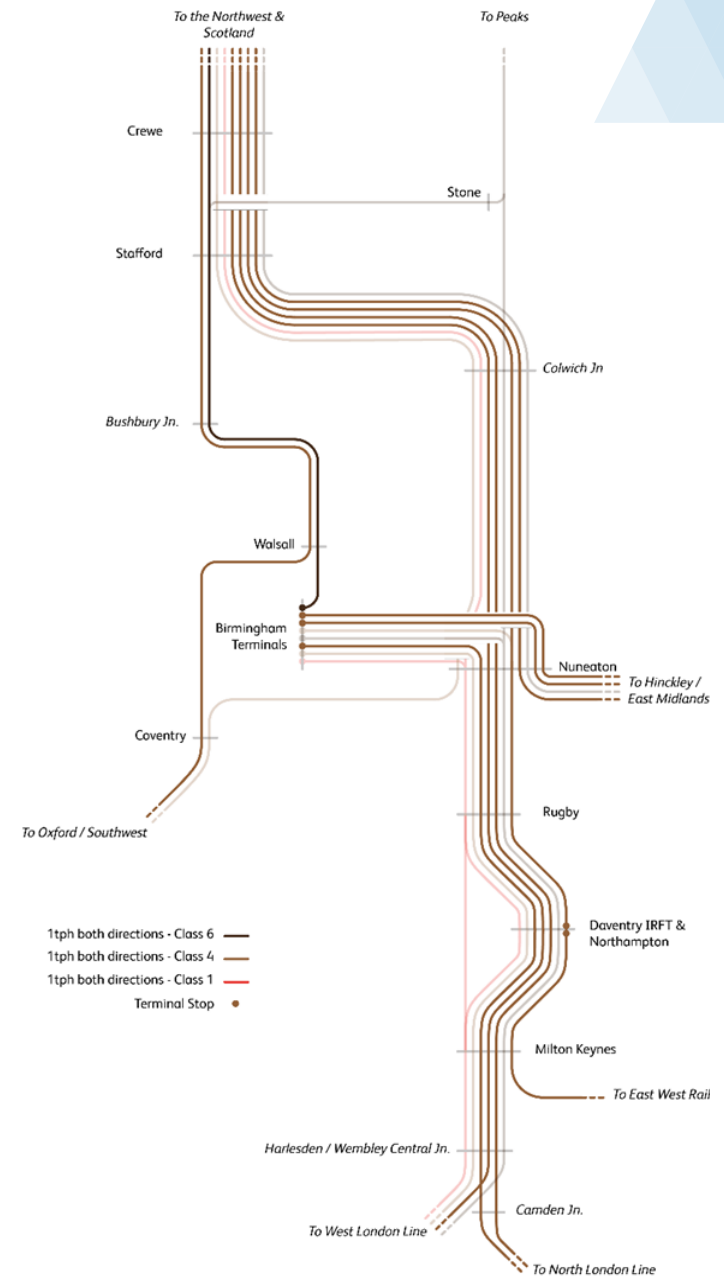
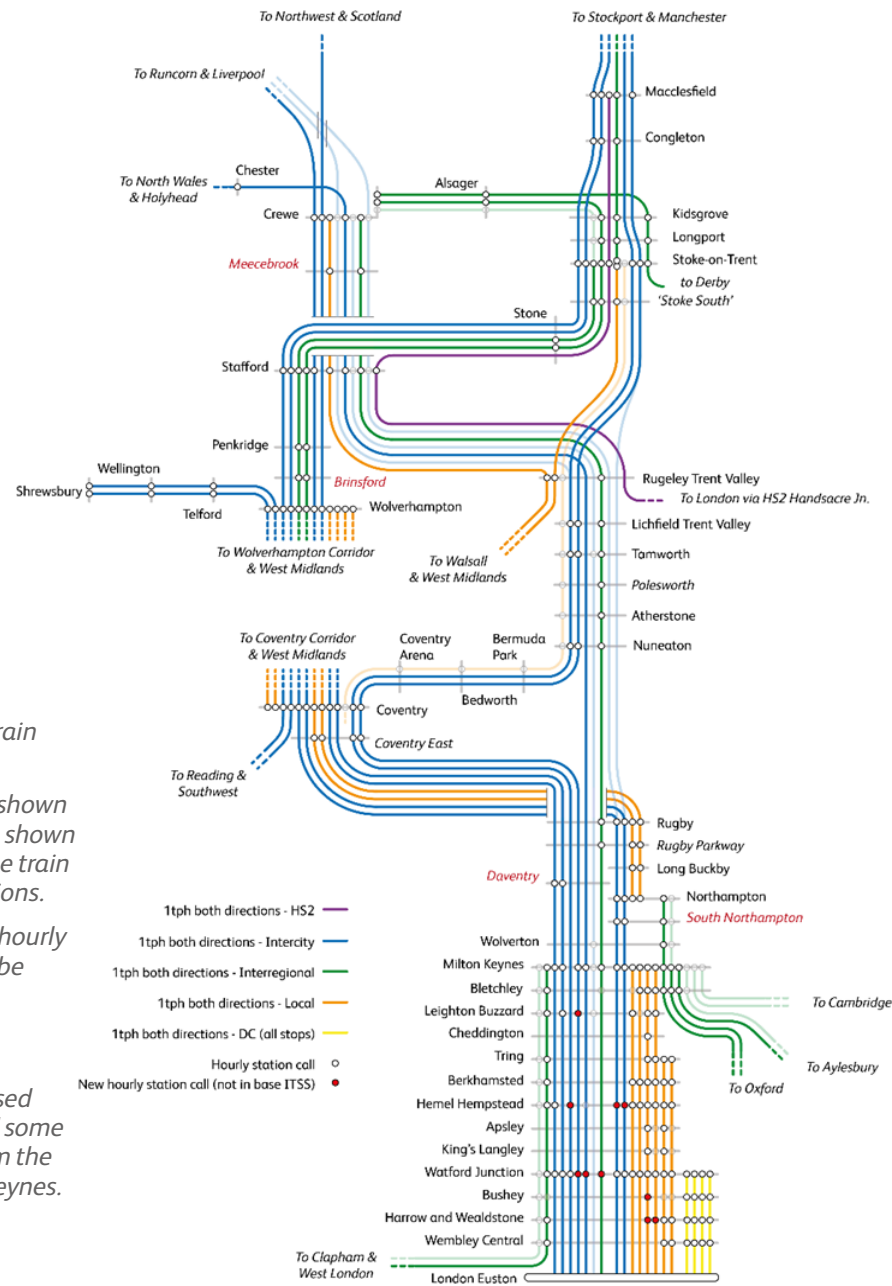

Figure 45: New Connections released capacity concept train plan.

Passenger service structure shown left, freight service structure shown right. One line represents one train path per hour in both directions.

Transparent lines represent hourly train paths which could not be accommodated on the conventional network infrastructure.

The New Connections released capacity train plan included some calling pattern changes from the Base ITSS south of Milton Keynes.

The Generalised Journey Times achieved in the New Connections released capacity concept train plan were generally less positive than those identified in the previous Intermediate Markets and East West Connectivity scenarios.

Some significant improvements were identified primarily for locations to the south of Milton Keynes, however some very significant disbenefits were observed, particularly for the longest-distance flows within scope where overall GJTs were longer than those observed in the December 2022 timetable. This was driven by the need to prioritise track capacity for calls at assumed new stations on constrained parts of the network, namely on the fast lines near Daventry and on the slow lines south of Northampton. Accommodating calls at these stations consequently limited the ability to provide all intercity-type services to the north, severely limiting connectivity between locations at the south end of West Coast South route and those on the Trent Valley and into the Northwest, as shown in Table 33.

The results of the analysis, particularly when compared to the results of previously tested scenarios, demonstrate the extent of the trade-off between serving new stations proposals at constrained parts of the network, and the ability to utilise released capacity to provide an improvement in connectivity for existing stations. The GJT figures generated suggested that prioritisation of calls at all new stations, including at Daventry and South Northampton alongside all existing, yielded a significant deterioration in connectivity for a range of currently established intermediate, non-HS2 flows when compared to the December 2022 timetable.

The need to rearrange calls on both the fast and slow lines to accommodate new stations, as well as provision of an additional Class 4 freight path, severely constrained the ability to plan intercity or interregional type services to Northampton. Further analysis must be undertaken before development of any new stations proposals to the south of Rugby, given the potential detrimental impact such proposals could have on providing improvement in service levels and connectivity at Northampton proper. This has been captured and explained in more detail as part of the recommendations in section 6 of this report.

Table 33: New Connections released capacity train service key generalised journey times

Origin	Destination	GJT vs Dec'22 (minutes)
Major Improvements		
Coventry	Lichfield	-41
	Tamworth	-30
	Manchester	-28
	Stoke-on-Trent	-27
Leighton Buzzard	Wolverhampton	-44
	Shrewsbury	-40
	Manchester	-39
Watford	Shrewsbury	-57
	Manchester	-44
	Wolverhampton	-36
Significant Disbenefits		
Liverpool	Northampton	+64
	Milton Keynes	+63
	Tamworth	+37
	Lichfield	+34
	Watford	+13
	Rugby	+11
London	Stafford	+44
	Stoke-on-Trent	+35
Manchester	Rugby	+22
	Milton Keynes	+16

New Connections: Network Constraints

As in previous scenarios, the impact of planning slower freight services on the slow lines from London reduced the available capacity for passenger services. Again, this was a product of the speed differential between 110mph-capable passenger services, and Class 4 freight (limited to 75mph) and Class 6 freight (limited to 60mph). Sufficient slow line capacity was available however, to provide an improvement in passenger connectivity south of Bletchley as well as an uplift in freight services beyond today's level.

The assumed new station on the fast lines near Daventry meant some additional capacity was required for intercity calls there. The effect was compounded by new stations at South Northampton and Rugby Parkway where slow line capacity was similarly constrained. The basic effect was a need to remove some slow line services north of Milton Keynes to free up sufficient time to call remaining services at the new stations.

Bletchley to Milton Keynes

The route section between Bletchley and Milton Keynes again emerged as a constraint in this scenario. This was driven by the combination of intercity and interregional services on the fast lines, interregional and local services terminating at Milton Keynes on the slow lines, and the addition of East West Rail passenger and freight services coming on to the West Coast South slow lines at Bletchley.

This capacity bottleneck limited the ability to plan all specified East West Rail passenger services through Milton Keynes, as well as generating a potential impact on performance and resilience.

Capacity utilisation was however, lower than in the previous East West Connectivity scenario as some services had to be omitted because they could not be timed through the new stations further north. Addressing the capacity bottleneck between Bletchley and Milton Keynes was found generate sufficient flexibility to reintroduce these services, though addressing additional constraints associated with the position of new stations in the Northamptonshire area would be needed also.

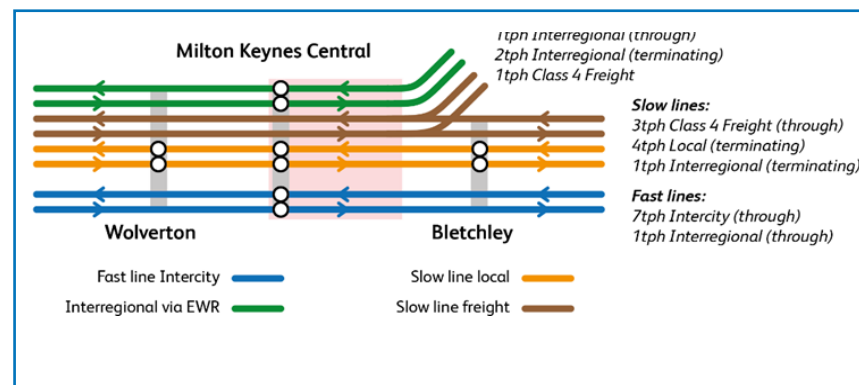

Figure 46: Capacity bottleneck Bletchley-Milton Keynes in the East West Connectivity released capacity train plan.

Slow Lines via Northampton

The slow lines via Northampton emerged as an acute constraint in this scenario. This was driven by the need to call some passenger services at Northampton, Long Buckby and both new stations at Rugby Parkway and South Northampton. The general effect was to spread the flight of trains out, reducing available capacity on this line of route.

Incorporating new stations on the Northampton slow lines drove a significant trade-off in using the capacity released by HS2 by further compromising an already challenging section of route. While a viable train service could be planned for the new stations, this had a detrimental effect on existing stations where the quantum of service had to be reduced. This was most obviously the case at Northampton, where new local stations had the direct impact of reducing flexibility to plan intercity-type services from Northampton to the Northwest, as well as limiting the ability to extend more than one train per hour from East West Rail beyond Milton Keynes.

The omission of intercity-type services to the Northwest from Northampton resulted in a reduced quantum of service crossing at Colwich and Rugeley North junctions when compared to previous scenarios. The trade-offs imposed by new stations at Daventry and on the Northampton slow lines had the effect of removing a constraint observed in other scenarios by forcing a reduction in the comparative quantum of service further north. Any infrastructure investment aimed at reintroducing these services may then drive a consequent need to address the Colwich/Rugeley North constraint too.

Coventry and Nuneaton

As in the East West Connectivity scenario, routing intercity-type services from London to the Northwest via Coventry and Nuneaton created some constraint driven by the sub-optimal track layouts, platform approaches and – in the case of Nuneaton – platform lengths.

While the 2tph intercity services through Coventry and Nuneaton specified in the base ITSS could be compliantly planned on the existing infrastructure, it is highly unlikely that they could be accommodated alongside any additional local service uplifts, nor could performance and resilience be sufficiently protected. The additional flexibility required accorded with the findings of the previous scenario and has been captured in the infrastructure recommendations in section 6.2.

Stoke-on-Trent Area

The base ITSS for this scenario specified additional local and interregional services to Stoke-on-Trent. As in the previous passenger focused scenarios, this required sub-optimal arrangements to either terminate on the running lines at Stoke-on-Trent or undertake empty coaching stock moves into a siding. It is also highly unlikely that any additional local service aspirations not included in the scope of this work could be incorporated on top of the services planned in this scenario. Again, the single-track section at Alsager represented an immediate constraint limiting the ability for released capacity services to terminate in the bay platforms at Crewe.

A more geographically focused strategic assessment is required for the Stoke-on-Trent area, capturing train service and infrastructure options which use the outputs from this workstream as a base. The requirement for this further study has been captured in the recommendations and next steps in sections 5 and 6 respectively.

New Connections: ‘With Infrastructure’ Concept Train Plan

The cumulative impact of the new stations incorporated into this scenario reduced the overall quantum of service which could be compliantly planned on to the existing infrastructure when compared to other passenger-focused scenarios.

Accommodating omitted services back into the plan, and prioritising calls at assumed new stations, drove an according need to a greater level of infrastructure enhancement than was identified in the other scenarios

Provision of additional track from Bletchley and new platforms at Milton Keynes Central were required to allow for all six East West Rail services specified in the base ITSS. Crucially, in this scenario, provision of a northern connection at Milton Keynes Central – where East West Rail trains could be planned via new through platforms – provided sufficient flexibility to time 2tph Oxford-Northampton via the new South Northampton station, bringing the service provision there to 4tph in total. A through connection also released sufficient platform capacity at Milton Keynes Central to plan the second Clapham Junction-Milton Keynes service.

Further infrastructure was required however, to re-route a Class 4 freight service via the fast lines and provide sufficient capacity to include intercity-type services to Northampton on the slow lines. This was a requirement emerging specifically in this scenario, and directly attributable to the impact of the multiple new stations assumed.





The results of the multi criteria assessment shown in Table 34 show some significant improvements in passenger-related objectives, especially when related to other scenarios tested. This is because the results for the released capacity plan in this scenario were limited, meaning the introduction of omitted services from the base ITSS had a greater comparative impact within the scenario. Ultimately, this suggests that the need for supporting infrastructure across the route will be greater if released capacity is focused initially on supporting new stations proposals in challenging parts of the network. This did not extend to freight services which could only be re-routed to achieve the requisite passenger service levels for this scenario. This further suggests prioritisation of new stations in the Northamptonshire area drove a trade-off with potential freight uplift.

Table 34: New Connections 'with infrastructure' concept train plan multi-criteria assessment results.

New Connections 'with infrastructure' results (all results relative to New Connections released capacity train plan)

Service Changes

- +1tph Intercity London-Crewe/Liverpool
- +1tph Interregional Aylesbury-Milton Keynes Central
- +2tph Interregional Cambridge-Milton Keynes Central
- 1tph Oxford-Milton Keynes extended to Northampton

Objective	Multi-Criteria Assessment Measure	Additional % vs released capacity
	<p>Maximise Revenue</p> <p>Total forecasted revenue generated from passenger abstractions.</p>	+4.8%
	<p>Supporting Development</p> <p>Forecasted value of time (VoT) benefits weighted for relative deprivation for each corresponding origin and destinations.</p>	+21.3%
	<p>Encourage Modal Shift</p> <p>Total passenger miles abstracted from road to rail.</p>	+9.7%
	<p>Stimulate New Markets</p> <p>Total value of time benefits for flows classified as new markets, either not directly connected or not frequently served.</p>	+16%
	<p>Support Freight Growth</p> <p>Total freight marginal external costs (MEC) benefits measured by the emissions reduced through modal shift from road to rail.</p>	+0%

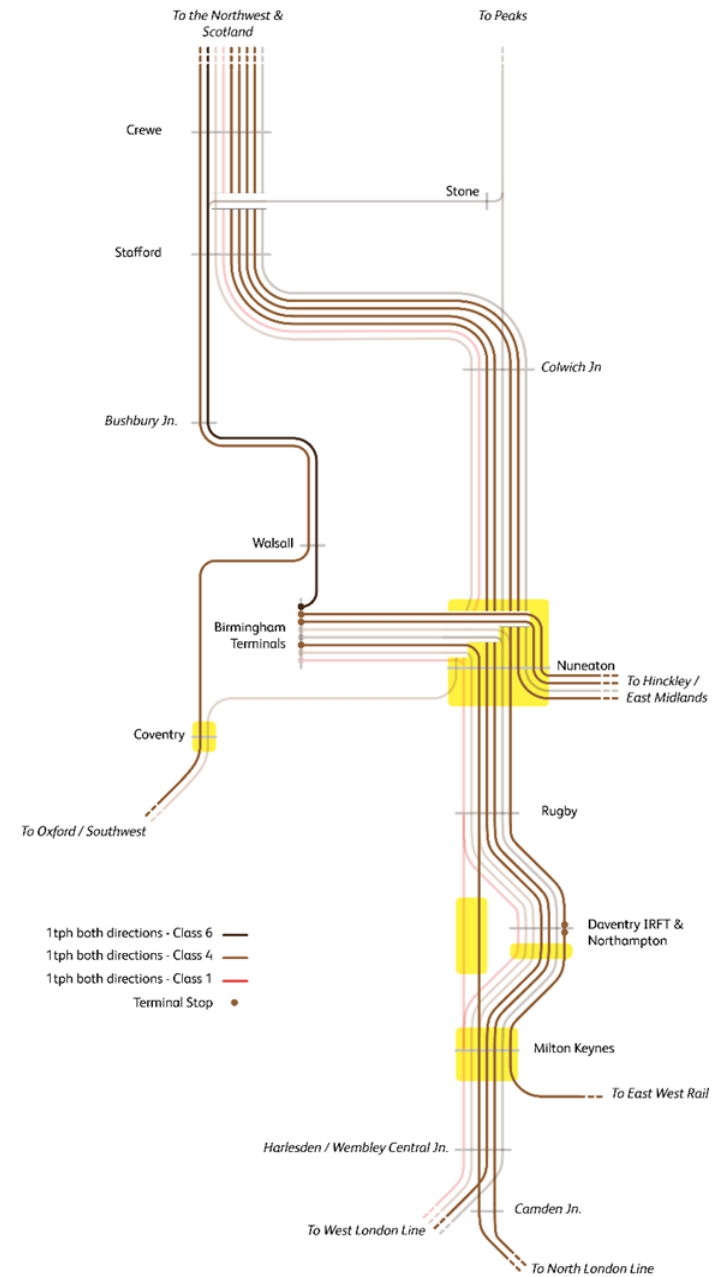
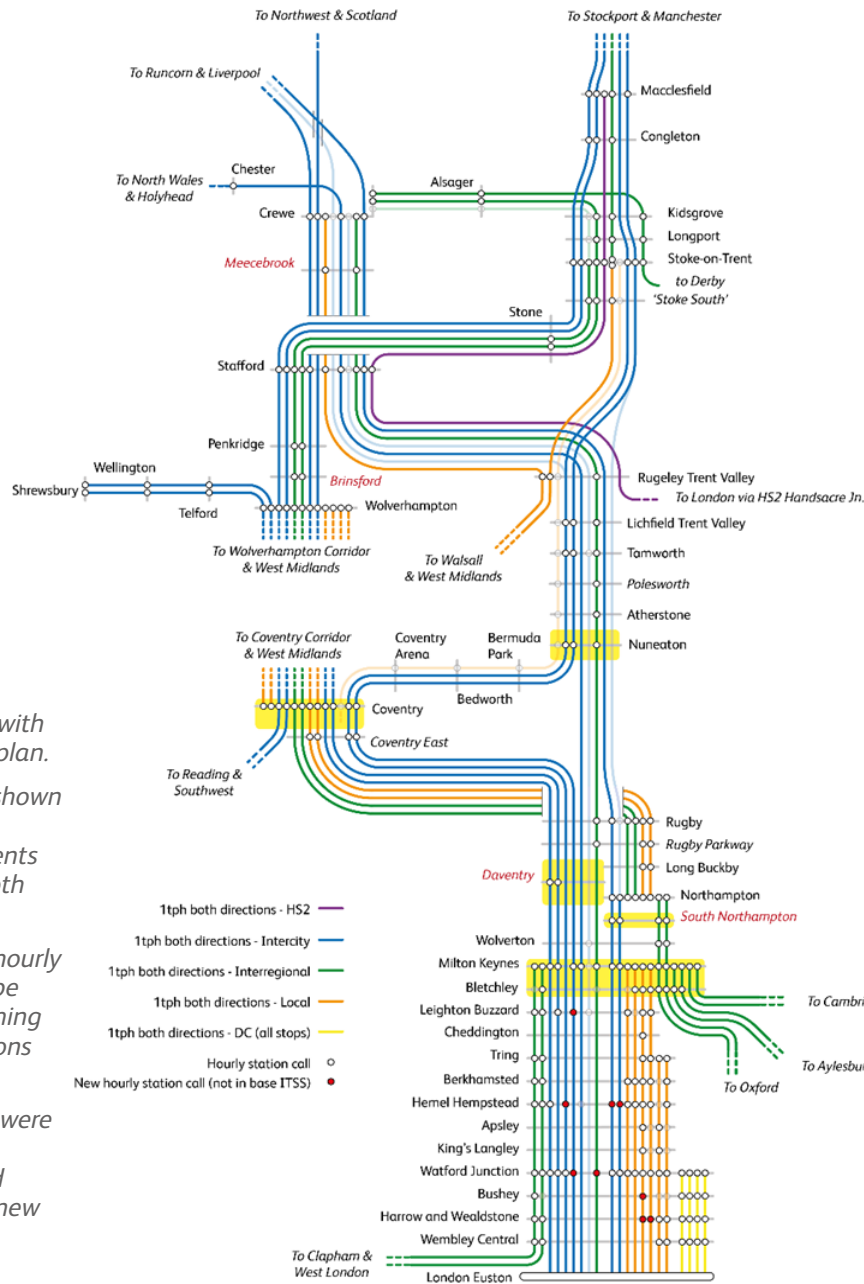

Figure 47: New Connections with infrastructure concept train plan.

Passenger service structure shown left, freight service structure shown right. One line represents one train path per hour in both directions.

Transparent lines represent hourly train paths which could not be accommodated when assuming the infrastructure interventions identified.

Infrastructure requirements were determined primarily by the extent to which they allowed prioritised services to call at new stations.

The most immediate infrastructure constraint encountered in this scenario was between Bletchley and Milton Keynes. A fifth track option with additional bay platforms at Milton Keynes Central permitted terminating services from East West Rail to be moved from the existing platforms. This freed up capacity for the second West London Line service and generated a potential improvement in performance by lowering local capacity utilisation. However, as in previous scenarios, a sixth track option was required to fully unlock the six specified passenger services per hour to Milton Keynes, as well as an hourly freight path via East West Rail. A northeast chord at Bletchley could provide a routing option, however, it is recommended that this is explored alongside options for additional track to Milton Keynes which provided sufficient flexibility to plan both passenger and freight services from the Cambridge direction.

The constraints encountered on the slow lines through Northampton were particularly acute. Extension of both hourly passenger services from Oxford to Northampton could only be accommodated in this scenario through provision of new through platforms at Milton Keynes Central (in lieu of bays), utilising the additional planning flexibility to meet timings at Wolverton, South Northampton and Northampton.

As in the previous East West Connectivity scenario, routing intercity-type services via Coventry and Nuneaton could be compliantly planned but would require infrastructure intervention to ensure resilience and sufficient capability for local service improvements in addition to those identified in this work.

Fast line freight loops were also required to accommodate one of the intercity services from London to the Northwest via Northampton. This was achieved by transferring an hourly Class 4 freight path to run via Weedon, and so freeing sufficient capacity on the slow lines via Northampton. Further change to the South Northampton layout – providing looping capability - would be required to call a second intercity service there per the base ITSS, though this imported the need for a significant dwell time, undermining the improvement in connectivity by reducing headline journey times to and from Northampton. The practicalities of provision of such a layout will depend on the exact location that is proposed for a station between Northampton and Hanslope Junction and has not been investigated in this work.

Again, these infrastructure requirements were a product of this scenario and the cumulative impact of the new stations at Daventry, South Northampton and Rugby Parkway (additional to existing stations at Northampton and Long Buckby). Further detailed work would be required to establish exact requirements and the case for these stations given the significant impact on network capacity and the consequent need for infrastructure to mitigate it.

At Meecebrook a 2tph service could be provided but this required calling an extended Chase Line local service as well as an interregional train which called at every location on the Trent Valley. This would not provide a compelling journey time to either the West Midlands or Stoke-on-Trent and would represent



a very significant infrastructure project to provide platforms on a four-track line of route. Siting the station on the lines between Norton Bridge Junction and Stone could be explored with an appropriate service provided by the 2tph interregional trains planned between Birmingham and Stoke-on-Trent. While the Meecebrook proposal did not drive any major service trade-offs elsewhere, it is unclear how the station could be served appropriately in its currently assumed location.

Recommendations related to new stations specifically have been captured in section 6, noting the potentially detrimental impact that some new stations proposals could have on the effective utilisation of conventional network capacity, and the increased requirement for infrastructure elsewhere on the route compared to other scenarios tested in this work.

Table 35: Infrastructure required to deliver the New Connections ‘with infrastructure’ train plan.

New Connections Infrastructure Options Results	
Infrastructure Intervention	Train Service Impact
Bletchley-Milton Keynes Fifth Track	+1tph Clapham Junction-Milton Keynes <i>Potential performance improvement through relief of capacity on approach into Milton Keynes Central.</i>
Bletchley-Milton Keynes Sixth Track	+1tph Aylesbury-Milton Keynes +2tph Cambridge-Milton Keynes* +1tph Clapham Junction-Milton Keynes <i>Potential performance improvement.</i> <i>*Passenger services from Cambridge direction would require Bletchley Northeast Chord.</i>
Bletchley Northeast Chord	+2tph Cambridge-Milton Keynes Central <i>Additional routing option for 1tph Class 4 freight planned into the released capacity train service.</i>
Milton Keynes Northern Connection	+1tph Aylesbury-Milton Keynes +2tph Cambridge-Milton Keynes +1tph Clapham Junction-Milton Keynes +1tph Oxford-Northampton (extension) <i>Potential performance improvement.</i> <i>Additional flexibility to extend Oxford-Northampton service which had to be pared back in this scenario released capacity plan.</i>
Nuneaton Remodelling	<i>Required to ensure sufficient planning flexibility and performance for +2tph London-Liverpool/Manchester (via Coventry and Nuneaton).</i>
Coventry Remodelling	<i>Required to ensure sufficient planning flexibility and performance for +2tph London-Liverpool/Manchester (via Coventry and Nuneaton).</i>
Weedon Fast Line Loops	+1tph London-Crewe/Liverpool <i>Freight via fast lines unlocked capacity via Northampton.</i>
South Northampton Four-track Layout	+1tph London-Northampton <i>Required extended dwell to plan additional service.</i>

New Connections: Summary and Recommendations

The analysis undertaken in this scenario showed the extent to which the capacity released by HS2 could be used to better connect underserved locations including service of a range of new stations proposals.

Even in a scenario where significant network capacity was utilised to incorporate new stations, the quantum of service at Crewe and into Manchester planned into the released capacity train service again exceeded the assumed known available capacity at Configuration State G:

Table 36: New Connections released capacity concept train plan services planned into Crewe and Manchester.

Interface	Configuration State G current assumptions	WCSSA New Connections released capacity	Difference
Crewe via Stafford	5tph passenger	5tph passenger	<i>nil</i>
	5tph freight	6tph freight	<i>+1tph</i>
Manchester via Stoke	4tph passenger	5tph passenger	<i>+1tph</i>

The enhancement options tested between Bletchley and Milton With the full range of infrastructure options tested in this scenario assumed, sufficient capacity was generated to provide another intercity-type passenger service between London and

Crewe via Northampton, adding to the overall quantum shown above.

Mirroring the findings of other scenarios tested in this work, the analysis shows the need to **deliver HS2 Phase 2B Crewe-Manchester in full**, and release further capacity via Crewe or Stockport into Manchester, to deliver fully on the objectives set in the New Connections scenario. Further work is required which considers how to generate sufficient capacity into the Northwest over the long-term and assess the options available. These findings, along with the results of all scenarios tested in this analysis, are being captured in Network Rail’s ongoing long-term strategic assessment for the northwest.

Likewise, the capacity released by HS2 could also be used to provide an uplift in intercity and local passenger services at Stoke-on-Trent. Further infrastructure enhancement may be required to assure performance and to provide any further capacity for local services not included in the scope of this work. Network Rail’s forthcoming Stoke Area Strategic Advice will build on the findings made in this report and assess the train service and infrastructure options available on that part of the network.

The infrastructure requirements for this scenario were greater than in other scenarios because of the additional constraints generated by assumed new stations which were position in challenging parts of the network, from a track capacity perspective. The Bletchley-Milton Keynes bottleneck was, as in all previous scenarios tested, an immediate constraint which had

to be addressed fully to create sufficient planning flexibility on the slow lines to Northampton. Once again, remodelling work at Coventry and Nuneaton was required to support routing intercity-type services via the Bedworth lines. Further however, achieving a level of passenger service commensurate with other scenario train plans required in addition passing loops on the Weedon fast lines (needed to re-route freight services and relieve the Northampton slow lines) and potentially a through line arrangement at a new South Northampton station to provide looping capability.

It is recommended that a detailed stations needs assessment is undertaken before development of any additional new stations between Milton Keynes and Rugby given the significant whole-system impact they are likely to import, and the consequent effect on train service and infrastructure options across the wider route.

All identified interventions have been captured in infrastructure recommendations in section 6. Requirements in the Stoke area will require further strategic assessment, incorporating uplift in local service provision which was not in scope for this work.



Scenario Five: Peak Commuter

Scenario Focus

Providing maximum on-train capacity into Euston conventional station in support of peak hour passenger flows.

Testing Purpose

To test what is required to accommodate a nominal peak hour and additional peak services into Euston conventional station, post-HS2.

Determine what train service trade-offs or infrastructure is required to support a peak hour service, and whether a sixteen-platform station at Euston becomes a train planning constraint during peak times.

ITSS Guiding Objective

The ITSS is structured to support high priority, short distance revenue flows.

Train Service Priorities

Prioritisation of suburban and intercity passenger services which provide maximum on-train capacity and journey time reductions into London.

De-prioritisation of freight services in one direction to make additional capacity available for standard hour passenger services.

Rationale

The fifth scenario tested in WCSSA was aimed at maximising available on-train capacity to support commuter flows. The rationale for this scenario test was both to assess the potential created by released capacity to uplift local and intercity services - primarily into London - but also to understand the capability of the infrastructure to support a nominal peak hour train service, post-HS2.

This scenario has not been used to develop any further major infrastructure enhancements, and has instead only assumed those identified in previous scenario tests. This is on the grounds that any major investments in the conventional network will need to support a peak and off-peak service provision. Instead, the testing has focused primarily on generating an AM peak concept train plan which incorporates:

- A significantly uplifted passenger service provision in the southbound direction,
- A de-prioritised freight provision in the southbound direction,
- Detailed analysis and platform occupation in the concept train planning at London Euston.

The results of this scenario test are intended to inform an assessment of the infrastructure to support a nominal post-HS2 peak hour train service which maximises the capacity available, with regard given to operations and capacity at

London Euston. The de-prioritisation of freight was aimed at providing a maximised released capacity passenger service into London Euston. In reality, a peak service could include passenger uplift with a reduced freight level, however given the specific purpose of the scenario freight was de-prioritised entirely in one direction. This is not a recommendation that no freight can be run in the peak in future on West Coast South Route.

Outputs from the multi-criteria assessment have been provided again for demonstrative purposes only, highlighting the extent to which shorter distance, high-revenue commuter flows could be supported in future following introduction of HS2 services. The results of the analysis should not be used to inform the exact requirements of a peak-hour timetable, but rather to understand the capability of the infrastructure when assuming a maximised utilisation of released capacity for commuter or peak flows into London following HS2.

As in all scenario tests, the Peak Commuter scenario incorporated all the Planning Principles outlined previously in this report. The scenario-specific requirements drawn from the results of the initial economic opportunity analysis were also reviewed by industry partners through the WCSSA working groups, with appropriate train service aspirations incorporated into the base ITSS.

Peak Commuter: Scenario-specific Requirements and Base ITSS

The Peak Commuter scenario-specific requirements were reflective of the unique purpose of the scenario within the context of the workstream to assessment a notional peak-hour service. As such, the passenger service requirements outlined in Table 37 are significantly beyond the minimum requirements and those incorporated into previous scenarios but apply in only one direction (southbound). Likewise, in this scenario only, requirements for freight in the southbound direction were removed in order to test the maximum capability of the infrastructure to plan a peak hour passenger service.

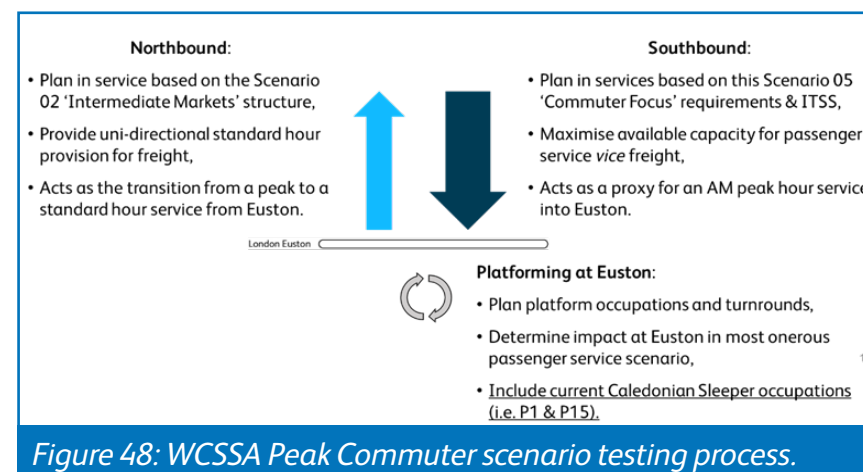

Figure 48: WCSSA Peak Commuter scenario testing process.



Accordingly, the train planning work undertaken tested the Base ITSS in the southbound direction only and included detailed platforming at London Euston conventional station per the layout described in the assumptions section of this report. Services terminating at Euston were then planned into a northbound standard hour, using the Intermediate Markets released capacity train service as proxy. This ensured that a notional peak hour service could be compliantly planned into a standard hour accounting for required Empty Coaching Stock (ECS) movements. This method differed from that undertaken in previous scenarios where a standard hour service was planned in both directions and as such the results are not directly comparable in terms of train service offer.

As in all scenarios tested throughout the course of this work, the requirements for the Peak Commuter scenario were reviewed and agreed with the industry as reflective of the focus and rational for the scenario. Likewise, per the testing methodology adopted in this work, no specific train paths were agreed before setting the scenario train service requirements. Instead, the base ITSS was constructed from first principles capturing the requirements by configuring train paths to suit. Again, this was advised by and agreed with industry partners through the established governance process for West Coast South Strategic Advice.

The Base ITSS for the Peak Commuter scenario is shown in Table 37. This shows only a southbound hourly service structure, capturing the passenger services requirements outlined above and deprioritising freight in one direction only.

Table 37: Scenario-specific requirements for the Peak Commuter Base ITSS.

Type	tph	Origin	Destination
Limited Stop	2	Stafford	London
Limited Stop	2	Lichfield	
Limited Stop	2	Tamworth	
Limited Stop	2	Nuneaton	
Limited Stop	2	Rugby	
Limited Stop	2	Coventry	
Limited Stop	6	Northampton	
Limited Stop	8	Milton Keynes	
Limited Stop	6	Bletchley	
Limited Stop	6	Leighton Buzzard	
Limited Stop	6	Tring	
Limited Stop	6	Berkhamsted	
Limited Stop	6	Hemel Hempstead	
Limited Stop	6	Kings Langley	
Limited Stop	8	Watford	
Limited Stop	6	Harrow & Wealdstone	
Limited Stop	4	Wembley Central	
Limited Stop	4	Northampton	
Limited Stop	6	Milton Keynes	
Limited Stop	4	Bletchley	
Limited Stop	4	Leighton Buzzard	
Limited Stop	4	Tring	
Limited Stop	4	Berkhamsted	
Limited Stop	6	Hemel Hempstead	Harrow & Wealdstone
Limited Stop	4	Watford	
Caledonian Sleeper services planned per existing peak-hour operations			

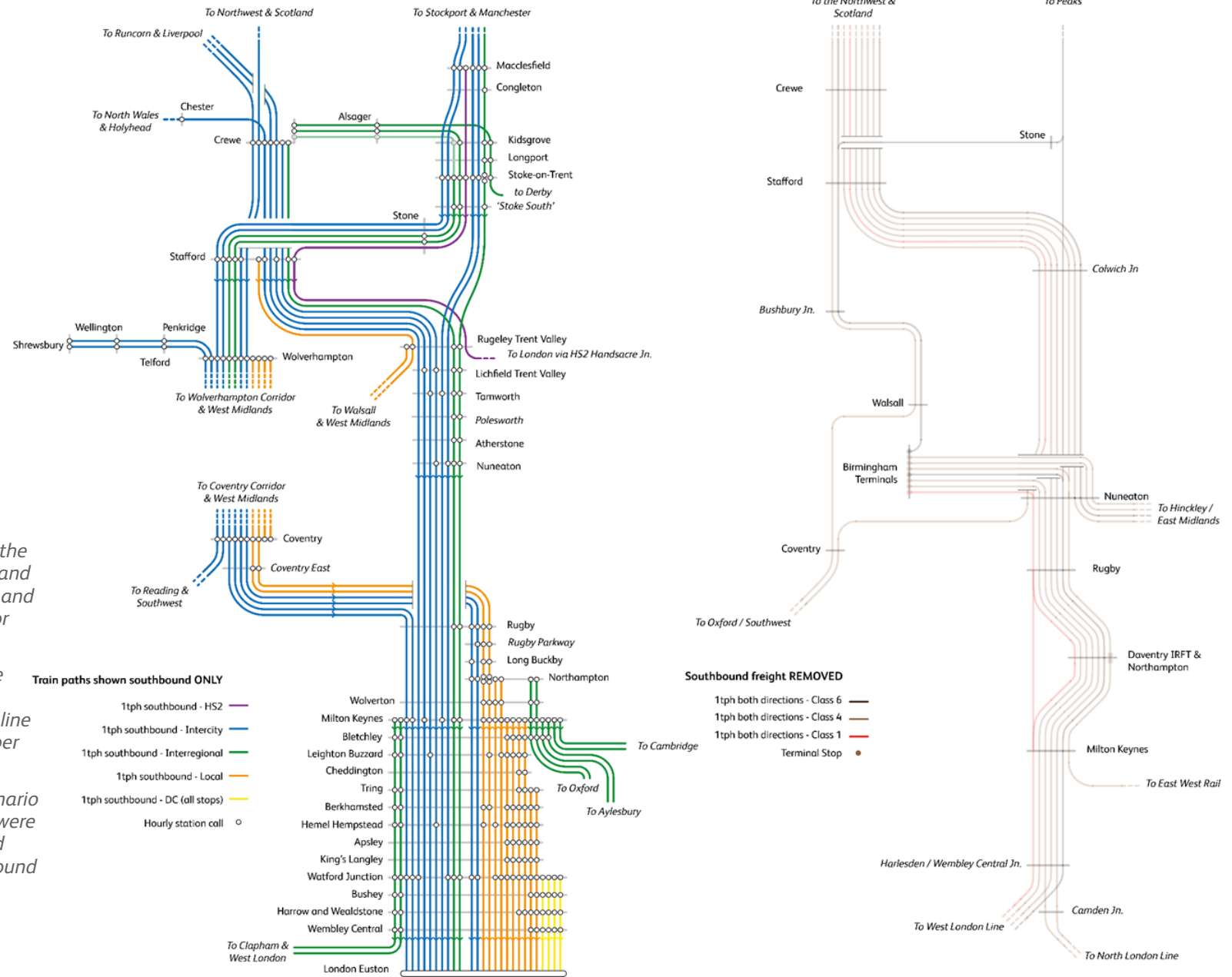

Figure 49: Peak Commuter scenario base ITSS.

The base ITSS captures all the train service requirements and objectives for this scenario and has been used as a basis for capacity analysis testing.

Passenger service structure shown left, freight service structure shown right. One line represents one train path per hour in both directions.

In the Peak Commuter scenario passenger services shown were planned in the southbound direction only, and southbound freight de-prioritised.

Peak Commuter: Released Capacity Concept Train Plan

The Peak Commuter released capacity train service was tested using the multi-criteria method applied to all concept train plans presented in this work. The results were in line with what may be expected from a train service which prioritised a high quantum of passenger service and single-direction operation for freight. The results of the freight objective assessment showed a significant reduction in benefits compared to the other standard hour scenarios in which a full provision for freight was accommodated.





There was significant improvement across the revenue, economic development and mode shift objectives, reflective of the high quantum of service planned into London via the trunk West Coast South Route. The results for the new markets objective were less pronounced. This was because train service improvements in this scenario were focused on established flows and did not extend to further uplifts for currently underserved or unconnected rail markets beyond those specified in the Planning Principles and featuring in every scenario ITSS.

The results show the extent of the benefits which could be achieved when prioritising passenger services supporting shorter-distance revenue flows into London via West Coast South, and utilising capacity to maximise headline journey times and on-train capacity for commuters. However, the removal of freight services in the southbound objective required to achieve these outputs will not be an acceptable outcome for standard hour

operation and therefore it is imperative that this scenario should be understood as a peak hour sensitivity.

The de-prioritisation of freight in the southbound direction created sufficient capacity for almost all required passenger services in the released capacity concept train plan, as shown in Figure 49. Only two hourly paths Northampton-London could not be accommodated, forcing a revision of calling patterns in the remaining 4tph suburban-type services. In addition to the 2tph limited-stop services from Northampton, this would still represent a very significant uplift in peak passenger provision when compared to the December 2022 timetable.

Table 38: Peak Commuter released capacity train service multi-criteria assessment results.

Objective	Multi-Criteria Assessment Measure	(% Change from post-HS2 economic baseline)
	<p>Maximise Revenue Total forecasted revenue generated from passenger abstractions.</p>	<p>5.8%</p>
	<p>Supporting Development Forecasted value of time (VoT) benefits weighted for relative deprivation for each corresponding origin and destinations.</p>	<p>3.5%</p>
	<p>Encourage Modal Shift Total passenger miles abstracted from road to rail.</p>	<p>5.4%</p>
	<p>Stimulate New Markets Total value of time benefits for flows classified as new markets, either not directly connected or not frequently served.</p>	<p>15.4%</p>
	<p>Support Freight Growth Total freight marginal external costs (MEC) benefits measured by the emissions reduced through modal shift from road to rail.</p>	<p>N/A</p>

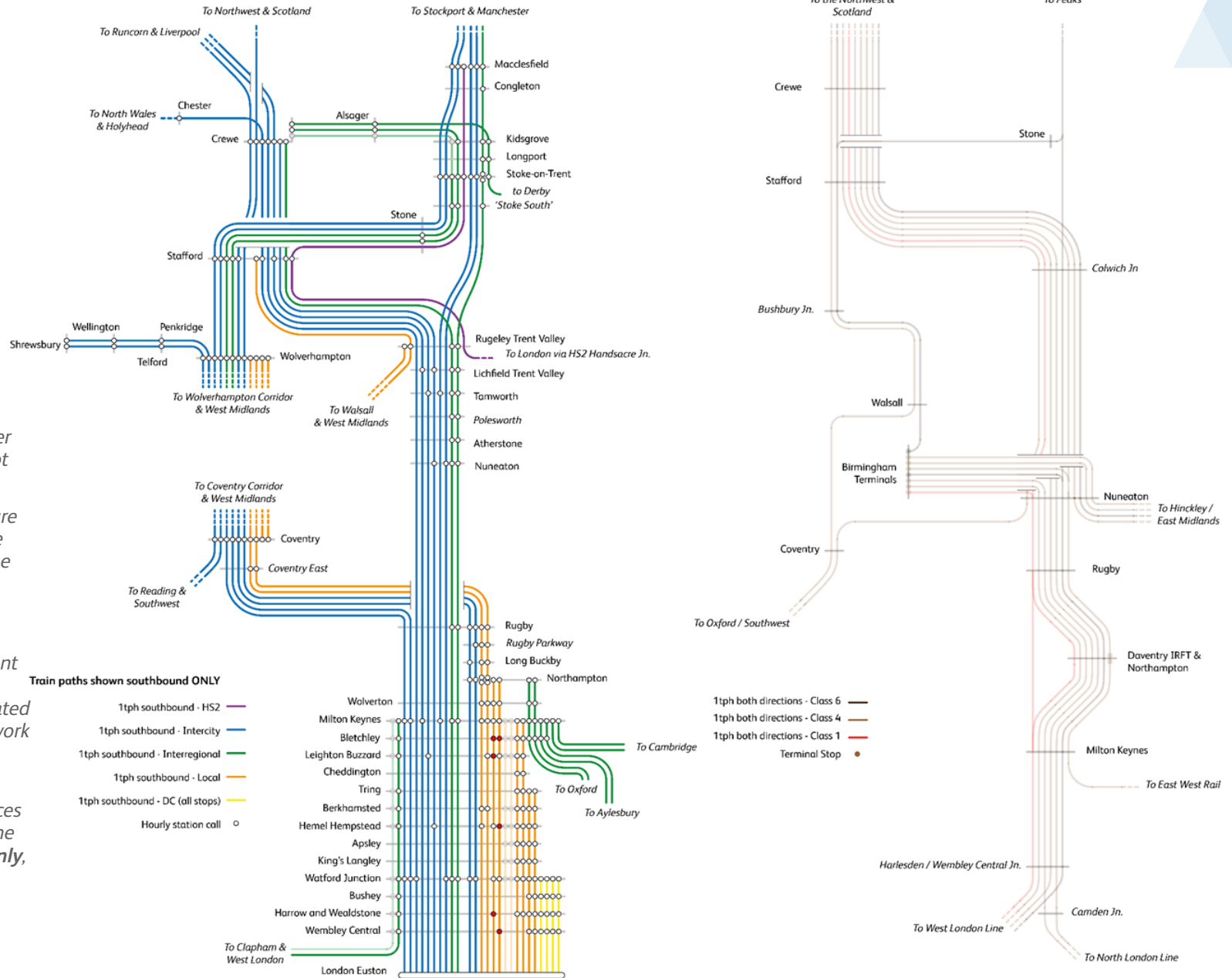

Figure 50: Peak Commuter released capacity concept train plan.

Passenger service structure shown left, freight service structure shown right. One line represents one train path per hour in both directions.

Transparent lines represent hourly train paths which could not be accommodated on the conventional network infrastructure.

In the Peak Commuter scenario passenger services shown were planned in the **southbound direction only**, and southbound freight de-prioritised.

Peak Commuter: Network Constraints

The primary purpose of constructing and testing a peak hour train service was to assess the capability of the infrastructure, including London Euston conventional station, to accommodate peak services following the release of conventional network capacity by HS2. This resulted in a significantly greater quantum of passenger service planned via the fast and slow lines to the south of Milton Keynes. Consequently the rate of capacity utilisation into London Euston was higher than that observed in previous scenarios. This was only possible because slow line capacity was available along the entire line of route due to the de-prioritisation of freight which is generally planned to enter or exit the West Coast Main Line at Wembley or Camden junctions in north London.

The assessment undertaken as part of WCSSA has focused on post-HS2 train service options and does not include pedestrian flow modelling or specific stations capacity assessment. It is anticipated that the Redevelopment of Euston Conventional Station (RECS) project will provide this analysis, based on the findings and train service options outlined in this report.

Slow Line Capacity Milton Keynes-London Euston

The primary constraint encountered in the train planning work for this scenario was available track capacity on the slow lines south of Milton Keynes. Even with freight removed, there was insufficient track capacity to provide all required intercity, interregional and suburban services per the base ITSS. Two hourly services Northampton-London could not be compliantly

planned and were not included in the Peak Commuter released capacity ITSS. The remaining passenger services could be accommodated with a compliant platform plan at London Euston, assuming a 16-platform layout. Caledonian Sleeper services were planned to occupy platforms one and fifteen for the full hour, per their operation in the December 2022 timetable structure, and a number of Empty Coaching Stock (ECS) moves were required to transition the peak southbound service into a standard hour northbound one.

In effect, this confirmed that Euston platform capacity is unlikely to emerge as an immediate constraint on planning the released capacity train service in a peak hour where it is under most pressure from a track capacity perspective. However, this assumes the following requirements which should inform future planning for the industry:

- No more than 4tph London Overground services can be planned into London Euston in a single hour,
- Platform 16 at London Euston must be re-provided if the existing platform is removed to make space for the new HS2 station.

Any change to these assumptions may impact the ability to provide a suitable peak train service maximising the capacity released by HS2 and would necessitate a revision of the findings of this analysis.

The testing undertaken for this scenario also planned sleeper

services occupying separate platforms simultaneously for the duration of the peak hour. This mirrors how sleeper operations occur in the December 2022 timetable. A sensitivity in the planning was undertaken which considered where the sleeper trains could be planned to occupy a single platform, entering and existing in sequence. This was possible with some adjustments to other services and did not require removal of any services already accommodated in the concept train plan.

Bletchley-Milton Keynes

The peak commuter scenario was not used to identify infrastructure enhancements, but rather assess constraints created by prioritising commuter services using only the capacity released by HS2. The train planning work undertaken showed that, in the southbound direction, a 6tph service could be planned from Northampton and Milton Keynes to the East West Rail infrastructure, per the requirements of the base ITSS. This did not require infrastructure to achieve a compliant train plan as the de-prioritisation of freight services and the removal of two of the Northampton-London suburban services in the southbound direction created sufficient capacity to include all required East West Rail paths on the existing infrastructure in this area.

However, the rate of capacity utilisation between Bletchley and Milton Keynes was very high, largely mirroring the results of the East West Connectivity scenario testing. This suggests that the infrastructure interventions identified in the previous scenarios between Bletchley and Milton Keynes may be required to

maximise peak hour service provision whilst protecting network performance in future.

Peak Commuter: Summary and Recommendations

This scenario was tested primarily to understand the how the capacity released by HS2 on the West Coast South route could be used to maximise peak passenger service provision, with freight de-prioritised in one direction. No scenario-specific recommendations on infrastructure enhancement were made in this scenario as a result, however there are some key recommendations which should be taken into account when planning for peak service provision in future.

Table 39: Peak Commuter released capacity concept train plan services planned into Crewe and Manchester.

Interface	Configuration State G current assumptions	WCSSA Peak Commuter released capacity	Difference
Crewe via Stafford	5tph passenger	7tph passenger	+2tph
	5tph freight	5tph freight	nil
Manchester via Stoke	4tph passenger	5tph passenger	+1tph

The peak scenario testing reflected the same constraints observed in other scenarios when planning services from the Northwest. As in all released capacity train plans, the Peak Commuter scenario included a level of passenger service from both Crewe and nominally from Manchester via Stoke-on-Trent that exceeds existing assumptions for Configuration State G

conventional services within the PLANET Framework Model (PFM), though this is assumed to be a standard hourly baseline. However, there clearly remains a need to **deliver HS2 Phase 2B Crewe-Manchester in full** and the further explore conventional network capacity through the Stockport Corridor. This is a finding aligned with the results of all other scenario tests undertaken as part of the WCSSA workstream.

Constraints identified in the Stoke-on-Trent area as were also similar to those observed in the other standard hour scenarios tested. Again, these have been considered in more detail, factoring in aspirations for local service improvements in the area, as part of Network Rail's Stoke Area Strategic Advice.

Primary Constraints and Enhancement Impacts

The findings of this scenario also generated some specific recommendations related to planning for a post-HS2 peak hour service. Critically, the results of concept train planning showed that slow line capacity between Milton Keynes and London Euston will remain the most immediate constraint on providing maximum peak hour service into London Euston, and Euston platforming did not emerge as a constraint specifically. This included peak hour operation of Caledonian Sleeper services; notionally the point at which Euston platforming is most constrained with two platforms occupied by sleeper trains simultaneously.

However, the following requirements will need to be met in future if this level of service is to be achieved:

- Platform 16 should be re-provided if the existing platform needs to be removed to make space for the new Euston HS2 station,
- No more than 4tph can be accommodated from the DC lines at the conventional station given the constraints imposed by the platform length, DC traction availability into the station and track capacity at Camden Junction,
- Sufficient land close to London Euston must be provided for stabling to manage the number of empty coaching stock moves resulting from transition from a peak to a standard hour; this includes existing locations at Euston Up Sidings, Camden Carriage Sidings and Willesden Depot.

The results of the testing in this scenario also showed that infrastructure more widely on the route was not needed to support the scenario-specific requirements for the Peak Commuter base ITSS. However, as in all scenarios tested in this work, a high capacity utilisation rate was observed on the route section between Bletchley and Milton Keynes, representing a potential threat to performance. The infrastructure options identified in the other, standard hour scenarios for this part of the network are highly likely to retain utility and generate significant benefit in a peak hour scenario in future.

Slow Line Headways and European Traffic Control System (ETCS) Signalling

The only passenger service trade-off made in this scenario – the omission of 2tph suburban services Northampton-London – was driven by the exhaustion of slow line capacity into London. The existing 4-minute headway constrains the ability to plan local passenger services closer together in order to create a tighter flight of services. In the Peak Commuter scenario, where southbound freight has not been included in the initial plan, a reduction in headway could have a significant impact meaning (subject to a replan of the CTP) these omitted services could be included. However, as in the previous scenario tested, a major re-signalling project is not recommended on the grounds that:

- Almost all required services in this scenario could be planned using existing headways and so a major re-signalling scheme is unlikely to represent value for money,
- The roll-out of ETCS digital signalling planned for the mid-2040s on this route may represent an opportunity to reduce slow line headways commensurate with those on the fast lines (currently 3 minutes).

As a result, the WCSSA study has not created any concept train plans which assume a reduction in slow line headways. Headway reductions on the slow lines into Euston may impact on the ability of the conventional station as to act as a terminus given the potential for additional slow line services - beyond the quantum identified in the Peak Commuter scenario - to

be planned into the same number of platforms. The analysis may need to be revisited in future if ETCS roll out can provide a reduction in headways to assess whether the capacity created is usable for Euston-bound passenger services.

Given the results of the testing undertaken within this work across the standard-hour scenarios, it is unlikely that Euston conventional station will become a significant constraint on accommodating future train services post-HS2. The service provision included in the Peak Commuter scenario is much greater than that provided in the December 2022 timetable, and the removal of the longest distance intercity services to the high-speed network will serve to reduce cumulative required turnrounds thereby generating some additional flexibility to accommodate an uplift in service. It is however, critical that the existing platform 16 is re-provided to ensure sufficient capacity for intercity-type services to terminate, maintaining an appropriate balance of short and long platforms across the conventional station footprint.

Redevelopment of Euston Conventional Station (RECS)

As noted in the assumptions for this report, Euston conventional station has historically suffered from significant pedestrian flow issues and crowding. The RECS programme is working toward addressing these issues by redeveloping the conventional station entirely once the HS2 Euston station is open and the Configuration State G high-speed services in full operation. The options and requirements for this work are being worked through within the industry, with a view to delivering a conventional

station that is fit for future passenger use in the end station.

It is anticipated that the RECS construction programme will require some platforms at the conventional station to be taken out of use. This will reduce available platform capacity for terminating services. Network Rail will use the outputs of the Peak Commuter scenario as a baseline to assess the impact of the range of construction options associated with the RECS programme. This work will identify where changes to the future train service may need to be made to ensure the programme can continue, and will explore appropriate mitigations to ensure the opportunities associated with released capacity are not significantly compromised by the RECS construction programme.

Findings and Recommendations



The following subsections provide recommendations based on the results of the scenario-based testing described above. They relate primarily to utilisation of released capacity and infrastructure enhancement options, with some consequential recommendations related to the future operator map, rolling stock operation/procurement, stations, freight operations and power supply.

Utilising Released Capacity

The analysis undertaken in West Coast South Strategic Advice has not attempted to define a single train service specification for the post-HS2 period. Instead, it has tested a series of scenarios which have sought to include the requirements set in the Planning Principles for this work, and then utilise the remaining conventional network capacity for different objectives and ends.

In every scenario a released capacity concept train plan was produced which did not assume any additional conventional network infrastructure on West Coast South route beyond that assumed in the baseline (outlined in Section 3). This demonstrated the extent to which the conventional network capacity released by HS2 could be used to support the guiding objectives and focus in any given scenario. The results generate an overarching finding: 

The conventional network capacity released by introduction of HS2 services offers significant opportunity to improve the train service operating on West Coast South route in any given scenario.

This is because the transfer of long-distance, Intercity West Coast trains to the high-speed infrastructure creates flexibility to plan conventional services differently and in support of a range of potential objectives for rail by improving frequency and connections for passengers and providing more capacity and routing options for freight.

In every scenario the freight and passenger service requirements identified in the Planning Principles governing this work (described in Section 4) could largely be achieved utilising released capacity only, with no additional conventional network infrastructure. The development of the post-HS2 timetable be determined through future work per the established timetable development process. This report recommends that: 





These general findings are evidenced by the comparative economic assessment undertaken in each scenario, both in terms of the relative changes in Generalised Journey Times between key origin-destination pairs when compared to today's (December 2022) timetable, as well as the improvements observed for the wider network against the post-HS2 baseline as part of the multi-criteria economic assessment.

An overview of the results of the multi criteria assessment for all released capacity train plans is provided in Table 40.

A released capacity train service should be developed aligned to the Planning Principles laid out in Section 4 of this report.

This will ensure that a reasonable improvement in freight and passenger service is achieved - agreed and endorsed by the wider industry - as well as alignment with the recommendations on long-term infrastructure development made in this report.

Table 40: Measures of change of the five objectives against the post-HS2 economic baseline for each Concept Train Plan without additional infrastructure. Comparisons can only be drawn within an objective and not across objectives

Objective	Measurement	Freight Focus	Intermediate Markets	East West Connectivity	New Connections	Commuter Peak	
(% Change from post-HS2 economic baseline)							
	Maximise Revenue	Total forecasted revenue generated from passenger abstractions.	5.1%	5.5%	5.2%	5.0%	5.8%
	Supporting Development	Forecasted value of time (VoT) benefits weighted for relative deprivation for each corresponding origin and destinations.	0.7%	2.3%	4.1%	2.9%	3.5%
	Encourage Modal Shift	Total passenger miles abstracted from road to rail.	4.6%	5.2%	5.2%	4.7%	5.4%
	Stimulate New Markets	Total value of time benefits for flows classified as new markets, either not directly connected or not frequently served.	20.6%	21.6%	28.5%	12.7%	15.4%
	Support Freight Growth	Total freight marginal external costs (MEC) benefits measured by the emissions reduced through modal shift from road to rail.	55.1%	-1.2%	19.9%	19.9%	N/A



Multi Criteria Assessment: Comparative Improvements

Table 40 shows the results from the multi criteria assessment for all released capacity concept train plans produced as part of this work, with the percentage change from the post-HS2 economic baseline for each objective. The results are not intended to quantify the absolute benefit in any scenario but show the extent to which a comparative improvement can be achieved by focusing the use of network capacity in service of a specific objective or set of objectives.

As the results show, it was possible to improve on all objectives to some degree. This was driven primarily by incorporating the requirements for all the planning principles in every train plan, the general effect of which was to provide some significant improvements in the passenger service in every scenario – for example, an hourly service between Shrewsbury, Telford and London – and therefore some positive impact against every passenger-related objective.

The only objective test which did not control for HS2 and instead provided a comparison against today's network was the freight assessment. Again, the results showed the extent to which a very significant uplift could be achieved by focusing capacity utilisation for freight, but also that a freight benefit could be realised in every scenario without dramatically compromising an improved passenger offer (except for the Peak Commuter scenario in which peak hour contraflow for freight was assumed).

Multi Criteria Assessment: Trade Offs

The primary purpose of the comparative assessment was however, to demonstrate the extent to which released capacity can be used to maximise the relative benefits for a single or set of objectives at the expense of the others. While the general picture is one of significant opportunity based on the Planning Principles identified in Section 4 of this report, it must be stressed that: 

For example, the results of the multi criteria assessment demonstrate clearly that focusing on capacity and routing options for freight translates into a limited ability to target uplifted passenger revenue or service of new passenger markets via West Coast South route. Likewise, benefits accrued for freight are substantially reduced when conventional network capacity is utilised primarily for intercity and interregional-type passenger services per the Intermediate Markets scenario.

These trade-offs have been detailed in the testing results for each scenario and are shown in overview in the multi criteria assessment. Specifiers and funders must determine to what extent a given set of objectives will be prioritised in the released capacity timetable and consider the potential for train service options which reflect those objectives as identified this report.

Achieving the full range of released capacity benefits identified in any given scenario will be dependent on the ambitions and policies set by the government and wider industry.

West Coast South Strategic Advice has not selected a preferred train plan but has sought instead to provide a series of possible future options which maximise the benefit of released capacity in different circumstances.

These findings should be used as a basis for future decision making as the wider industry develops the post-HS2 network timetable.

Released Capacity Issues and Constraints

The capacity released by HS2 presents a significant opportunity for improvement but there are some remaining constraints and limitations. Several issues will persist into the long-term, including:

- a. The difficulty in retaining a level of service comparable to the pre-HS2 network baseline at some points (primarily between London and Coventry, Stoke-on-Trent, Chester) on the network without severely limiting the ability to provide improvement elsewhere,
- b. The need to effectively manage slow line capacity and the speed differential between passenger and freight services,
- c. The potential for a quantum of passenger service from West Coast South exceeding available capacity into the Northwest via Crewe and Manchester at Configuration State G,
- d. The opportunity to use released capacity to support investment in the East West Rail (EWR) and Felixstowe to Midlands and the North (F2MN) schemes.

Each of these issues will need to be considered in the development of the released capacity timetable and should inform ongoing strategic advice.

Reductions in Comparable Level of Service

In most scenarios the released capacity train plan resulted in an improvement, or a marginal change, in generalised journey times between most origin-destination pairs. The assessment did, however, identify some disbenefits in each released capacity train plan where some origin-destination pairs suffered a reduced generalised journey time.

This was an issue at both Coventry and Stoke-on-Trent where generalised journey times to and from London could not be significantly improved compared to today's values and were extended in some scenarios. This is driven by the existing train service structure in which long-distance, Intercity West Coast services between Birmingham, Manchester and London call at Coventry and Stoke-on-Trent. Retention of these services in the same structure is not possible post-HS2 - where these paths are 'transferred' to the high-speed network – without significantly compromising the ability improve passenger connectivity and freight capacity elsewhere, per the Planning Principles outlined in section 4.

Where an extension in generalised journey time was observed this was due to one or more of the following factors:

- Reduction in quantum of service from today's 3tph to 2tph for London-Coventry services,
- Incorporation of intermediate calls (on the grounds of widening connectivity) for both London-Coventry and London-Stoke services,

- Increased headline journey time for both flows when assuming non-tilt passenger rolling stock limited to 110mph.

Increased generalised journey times between Coventry and London could be mitigated per the findings in the East West Connectivity scenario through provision of additional intercity type services via Nuneaton and the Trent Valley. While this prospectively results in an even 15-minute interval service Coventry-London it would drive a trade-off by further increasing Stoke and Trent Valley journey times to London, and potentially drive a need for further infrastructure intervention at both Coventry and Nuneaton (subject to local service aspirations) to provide the additional 2tph.

Improved or comparable generalised journey time between London and Stoke-on-Trent could be supported by providing an increased level of fast, intercity-type service to London (3tph) per the Intermediate Markets scenario. This however, drives a significant trade-off in connectivity elsewhere, limiting the availability of intercity-type services calling on the Trent Valley or running via Coventry and Nuneaton, as well as increasing conventional network capacity through the two-track formation at Stoke-on-Trent itself.

Alternatively, consideration could be given to routing the planned HS2 service via Handsacre junction directly to Stoke-on-Trent to provide a faster headline journey to London and mitigating the impact of removing a call at Stafford in this service through a more frequent conventional offer. Likewise, the

requirement throughout the testing to retain and hourly intercity Chester-London service again created a trade-off between headline journey times for this service, and the ability to capture more calls elsewhere and widen connectivity. Serving Chester with an HS2 train (either via Crewe or Handsacre junctions) would fully release this train path from the conventional network providing a comprehensive solution. However, changes to the HS2 service specification were not in scope for WCSSA and have not been assumed in any concept train plans. Any changes would impact on HS2 timetabling and operations and would require validation and serving Chester specifically would drive a need for sufficient high-speed capacity for an additional service and electrification of the conventional route between Crewe and Chester.

In both instances, some of the risks around comparable level of service and increases in generalised journey time could be mitigated by implementation of Multiple Unit differential speeds, or raising the Permissible Speed from 110mph on the conventional network. This would effectively recoup some of the headline journey time lost following the removal of tilting trains from the network, whilst also protecting network capacity by maintaining the same speed profile for all passenger services. Such a change would alter the train timings assumed in the concept train planning work undertaken to produce this report and so a further capacity assessment would be required to generate compliant train plans and assess the impact of linespeed increases.

The industry continues to assess and develop the train service specification which will inform the timetable change on West Coast South for the post-HS2 period.

Consideration should be given to the most effective ways to mitigate the comparable service issues at both Coventry and Stoke-on-Trent in future, including options for infrastructure intervention per this report.

Ensuring that all passenger rolling stock can utilise any raise in speed profile will maximise journey time benefits and limit the detrimental impact on capacity associated with multiple passenger speed profiles.

Finally, as outlined in Planning Principle H, all WCSSA released capacity train plans separated local service groups between Euston and Northampton and between Northampton and Birmingham. This essentially severed direct connections between some local stops on the Euston and Coventry corridors with Birmingham and London respectively. For example, severing these service groups would remove direct connectivity between Tile Hill and London Euston and between Kings Langley and Birmingham New Street. However, no significant impact was identified in the generalised journey time analysis because the released capacity concept train plans improved options for interchange provided at Coventry, Rugby or Northampton, mitigating the impact of the loss of a direct connection.

Slow Line Capacity and Speed Differential

The impact of HS2 will be felt primarily on the West Coast South fast lines where the intercity passenger services that ‘transfer’ to the high-speed network are planned today. The analysis undertaken in all scenarios highlighted the difficulty in utilising slow line capacity efficiently, with a consequent need to plan a greater number of transitional moves – particularly for intercity and interregional-type services – between the fast and slow lines.

This meant that some junctions south of Rugby were more intensively used in the released capacity concept train plans than is the case today. Watford North Junction, Bourne End Junction, Ledburn Junction and Milton Keynes North and South junctions were all utilised over a standard hour. These junctions gave sufficient flexibility to plan additional freight and local stopping services, more efficiently using the capacity released by HS2 than would be possible if the opportunities to cross between fast and slow lines were reduced. Further, the junctions identified offer significant operational flexibility in times of perturbation, degraded working or when a two-track possession is required on this line of route. It is key that this functionality is also retained into the future.

The requirement for increased flexibility in planning transitional moves between fast and slow lines following introduction of HS2 services must be considered in maintenance and renewal of track assets.

It may not be possible to fully unlock the benefits associated with the release of conventional capacity by HS2 should the ability to plan transitional moves on West Coast South be reduced.

Permanent abandonment of existing junctions where fast and slow can be traversed should be avoided on the grounds of long-term strategic fit, ensuring the conventional network is ready to maximise the benefit associated with investment in HS2.



Slow line capacity was also acutely impacted by the inclusion of freight services in the released capacity train plans. The most effective way to achieve the minimum requirements set per the Planning Principles as well as an uplift in freight paths was to flight freight trains closely together across the length of the route. This is not a detrimental outcome as freight traffic – unlike passenger services – does not need to be planned on even intervals in order to attract customers and achieve the wider associated economic and social benefits.

Flighting freight services utilised network capacity efficiently but did generate a significant impact in the Freight Focus scenario where a slower Class 6 service required the same track capacity as three Class 4 services along the full length of West Coast South route. Accepting this trade off would either significantly lower the overall benefit accrued for freight or generate a passenger service trade-off which broke the minimum requirements outlined in the Planning Principles by forcing a need to remove more passenger services.

At present, freight services are not planned in a standard hourly pattern throughout the course of a day, and in many cases the slowest and heaviest services – which have the greatest impact on available track capacity – are planned at less busy times of the day, i.e. at night. There is no reason to assume these practices will end following introduction of HS2. There will remain potential to maximise the capacity available on West Coast South route for freight by concentrating heavily flighted Class 4 services at busier times of day and planning slower and heavier Class 6 services outside of the passenger service window.

Alternatively, further maximisation of national freight capacity could be provided by concentrating certain classes on different routes. Focusing West Coast South supporting growth in intermodal, Class 4 traffic could contribute to an optimisation of the national network for freight if according priority for service Class 6 flows could be found on alternative routes, for example via the Midland Mainline. This has not been tested within the WCSSA work given the scope of the assessment, though it would be a fruitful avenue for further work.

It is recommended that further work be undertaken on a pan-regional freight routing study to consider the national, network-wide opportunity to maximise capability for freight over the long-term.

This should consider what potential exists to segregate classes of freight by route, as well as by hour of operation, prioritising Class 4 freight movements via West Coast South over a standard hour.

Released Capacity Quantum of Service to the Northwest

The findings of the analysis undertaken as part of the WCSSA work – both the economic and concept train plan assessments – demonstrate the long-term imperative there is to support intermediate connectivity between locations on West Coast South and major urban centres in the Northwest, notably Liverpool and Manchester. It was found in all scenarios, including the freight focus scenario, that the passenger service requirements set to serve these intermediate markets could be achieved utilising released capacity. However, this resulted in a quantum of service planned into Crewe and to Manchester via Stoke-on-Trent exceeding that in HS2's base case for Configuration State G, per the assumptions of the Planet Framework Model (PFM). A summary of these results across all scenarios is shown in Table 41, identifying the number of additional services that could be accommodated using released capacity on West Coast South.

The minimum requirements set in the West Coast South Strategic Advice are based on an assessment of strategic need. These requirements may not be achievable in full given capacity constraints on the route from Crewe into Manchester at Configuration State G when three HS2 services per hour are operating on the conventional network between Crewe and Manchester. As such West Coast South Strategic Advice recommends that: 

To fully release conventional network capacity a segregated high-speed network should be built between London Euston and into Manchester including the route section from Crewe, per the committed core scope outlined in the government's Integrated Rail Plan (IRP).

Further strategic assessment will be required in the Northwest to identify how the minimum passenger service requirements identified in this work – across all scenarios - can be accommodated at Crewe and Manchester over the long-term.

Table 41: Trains per hour presenting at Crewe and Cheadle Hulme Junction in the WCSSA released capacity train plans compared to HS2 PLANET Framework Model assumptions.

WCSSA Scenario released capacity train plan	WCSSA trains at Crewe compared to base HS2 assumptions (tph)	WCSSA trains to Manchester via Stoke compared to base HS2 assumptions (tph)
Freight Focus	+1 Passenger +3 Freight	+1 Passenger
Intermediate Markets	+2 Passenger +1 Freight	+2 Passenger
East West Connectivity	+1 Passenger +2 Freight	+1 Passenger
New Connections	+1 Passenger +2 Freight	+1 Passenger
Commuter Peak	+2 Passenger	+1 Passenger

Integrating East West Rail and Felixstowe to Midlands and the North

East West Rail

The outputs of the East West Connectivity scenario demonstrated the potential to utilise released capacity to integrate the proposed East West Rail route between Oxford and Cambridge into the West Coast South network. This was achieved by prioritising and extending East West Rail-bound services in that scenario, nominally providing:

- Two passenger trains per hour Aylesbury-Milton Keynes,
- Two passenger trains per hour Oxford-Northampton,
- Two passenger trains per hour Cambridge-Birmingham,
- One freight train per hour Southampton or Felixstowe-Crewe.

These results demonstrated that a range of new markets could be stimulated through improvements in generalised journey times across the 'Heartland' region as well as offering new routing options for freight in line with Network Rail's East West Main Line Strategic Statement. This is not possible ahead of delivery of HS2 Configuration State G as there is insufficient capacity to reliably plan any more than two trains per hour from East West Rail via Bletchley alongside the pre-HS2 network baseline passenger service.

Conventional network capacity released by HS2 could be used to better integrate the East West Rail and West Coast South networks, generating potentially transformative improvements in passenger connectivity as well as more fully utilising the planned infrastructure between Oxford and Cambridge.

This however drives significant trade-offs should other objectives for the network be prioritised and exacerbates a major performance risk between Bletchley and Milton Keynes.

Further work will be required should this level of integration become a policy objective in future. It is recommended that this point of the West Coast South network is a focus for enhancement development.

While prioritisation of East West Rail passenger and freight services could be accommodated on the existing infrastructure post-HS2, it generated two key issues. Firstly, that prioritisation of East West Rail services generated a trade-off between distribution of connectivity to a wider set of locations and supporting existing, intermediate passenger markets or a high-growth level of freight. The East West Connectivity service structure limited the capacity available to plan intercity-type services on the trunk route and resulted in a need to provide more calls in fewer trains. This had the general effect of slowing down core West Coast South passenger services relative to other scenarios.

Secondly, the East West Connectivity scenario demonstrated the extent to which focusing on a wider distribution of connectivity via East West Rail infrastructure drove a very significant performance trade-off in the Bletchley-Milton Keynes area, with capacity utilisation at that point of the network reaching 90%. This is a serious risk to long-term performance and resilience, and exposes the impact of creating a capacity bottleneck on this part of the network without further infrastructure enhancement.

The testing undertaken in all scenarios highlighted the need to resolve the capacity bottleneck between Bletchley and Milton Keynes if infrastructure enhancement is in scope. The options to do this are included in the prioritisation assessment and recommendations on infrastructure development later in this chapter.

Felixstowe to the Midlands and the North (F2MN)

As described in Planning Principle A, the future rail system must be able to accommodate greater demand for rail freight in support of economic growth and decarbonisation through modal shift. The scenario testing undertaken in WCSSA shows that some improvement on today's level of freight is possible alongside significant improvements in passenger service using released capacity. Improvement in freight benefits which are commensurate with a high growth level of freight can be achieved by focusing on freight capacity and routing should this be a guiding objective.

The uplift in freight services across all scenarios required routing options alternative to London's orbital lines due to the specific constraints encountered when planning even a minimum passenger service to and from London Euston. The resultant potential for freight uplift on to West Coast South, from various external routes, is shown in Table 42.

It is unlikely that growing demand for freight movements between the West Coast Main Line and the east of England can be accommodated on top of freight from Thameside ports via London's orbital rail routes, as it is today. The testing undertaken in WCSSA is aligned with that direction of travel, showing that alternative routes for freight must be found if the capacity on West Coast South is to be used efficiently post-HS2, including in a high-growth freight scenario where capacity is *prioritised* for freight.

Table 42: Freight routings in WCSSA released capacity train plans. Constrained capacity between London and Milton Keynes requires greater use of alternative routing options over the long-term.

**1tph Class 6 could run in lieu of 3tph Class 4.*

***1tph Class 1 could run in lieu of 1tph Clapham Junction-Milton Keynes.*

Scenario released capacity train plan	Hourly freight trains via London		Hourly freight trains via Bletchley/EWR		Hourly freight trains via Nuneaton		Hourly freight trains via Penkridge/West Midlands	
Freight Focus	Class 1 Class 4 Class 6 Total	1tph 4tph* - 5tph	Class 1 Class 4 Class 6 Total	- 1tph - 1tph	Class 1 Class 4 Class 6 Total	- 2tph 1tph 3tph	Class 1 Class 4 Class 6 Total	- 1tph - 1tph
Intermediate Markets	Class 1 Class 4 Class 6 Total	1tph 3tph - 4tph	Class 1 Class 4 Class 6 Total	- - - -	Class 1 Class 4 Class 6 Total	- 1tph - 1tph	Class 1 Class 4 Class 6 Total	- 1tph - 1tph
East West Connectivity	Class 1 Class 4 Class 6 Total	-** 3tph - 3tph**	Class 1 Class 4 Class 6 Total	- 1tph - 1tph	Class 1 Class 4 Class 6 Total	- 1tph - 1tph	Class 1 Class 4 Class 6 Total	- 1tph 1tph 2tph
New Connections	Class 1 Class 4 Class 6 Total	- 3tph - 3tph	Class 1 Class 4 Class 6 Total	- 1tph - 1tph	Class 1 Class 4 Class 6 Total	- 1tph - 1tph	Class 1 Class 4 Class 6 Total	- 1tph 1tph 2tph

The findings of the WCSSA testing clearly demonstrate the opportunity that released capacity presents in bolstering the case for enhancements proposed as part of the Felixstowe to the Midlands and the North (F2MN) scheme, routing rail freight traffic from Felixstowe on to West Coast Main Line via Nuneaton and via East West Rail. Accordingly, WCSSA makes the following recommendation: 

Conventional network capacity released by HS2 could be used to fully utilise the enhancements proposed as part of the Felixstowe to the Midlands and the North (F2MN) scheme.

In all scenarios tested in this work - and especially in a high freight growth scenario - the most efficient use of released capacity required routing additional freight services via Nuneaton and, in most scenarios, via East West Rail.

Delivery of the F2MN scheme must be prioritised for the post-HS2 period if the full benefits of released capacity for freight are to be fully achieved.

Summary: Released Capacity Choices

The results of the scenario testing demonstrated the extent to which the capacity released by HS2 could enable greater integration between existing and planned routes on the conventional network. This is a significant opportunity to improve connectivity in the wider rail system, and further the objectives set for this work.

Utilising released capacity in full could accordingly generate an impact on parts of the network which were out of scope for this study, depending on the objectives set. In the freight focused scenario the significant uplift in quantum of freight paths required alternative routings which were not via London's orbital corridors. This created a dependency in this scenario on delivery of the F2MN scheme as well as a need to further consider freight-related enhancements in the Northwest or via West Coast Main Line North to provide end-to-end routing availability.

In the intermediate markets scenario - where priority was given to supporting existing, high-revenue flows - sufficient capacity was available to support an uplift in intercity and interregional-type services into the Northwest via Crewe and Manchester. However, this exacerbated capacity constraints in the Stoke-on-Trent area and into the Northwest which will need to be explored more fully in further strategic analysis.

In a connectivity focused scenario, the priority given to extending passenger services from East West Rail created a key dependency in delivery of the planned East West Rail

infrastructure between Oxford and Cambridge to achieve the origin-destination pairings targeted in that scenario. Planning intercity-type services via Coventry and Nuneaton also generated further interaction with the local West Midlands service structure driving a need to explore infrastructure enhancement in those areas to ensure the long-term capability of the infrastructure.

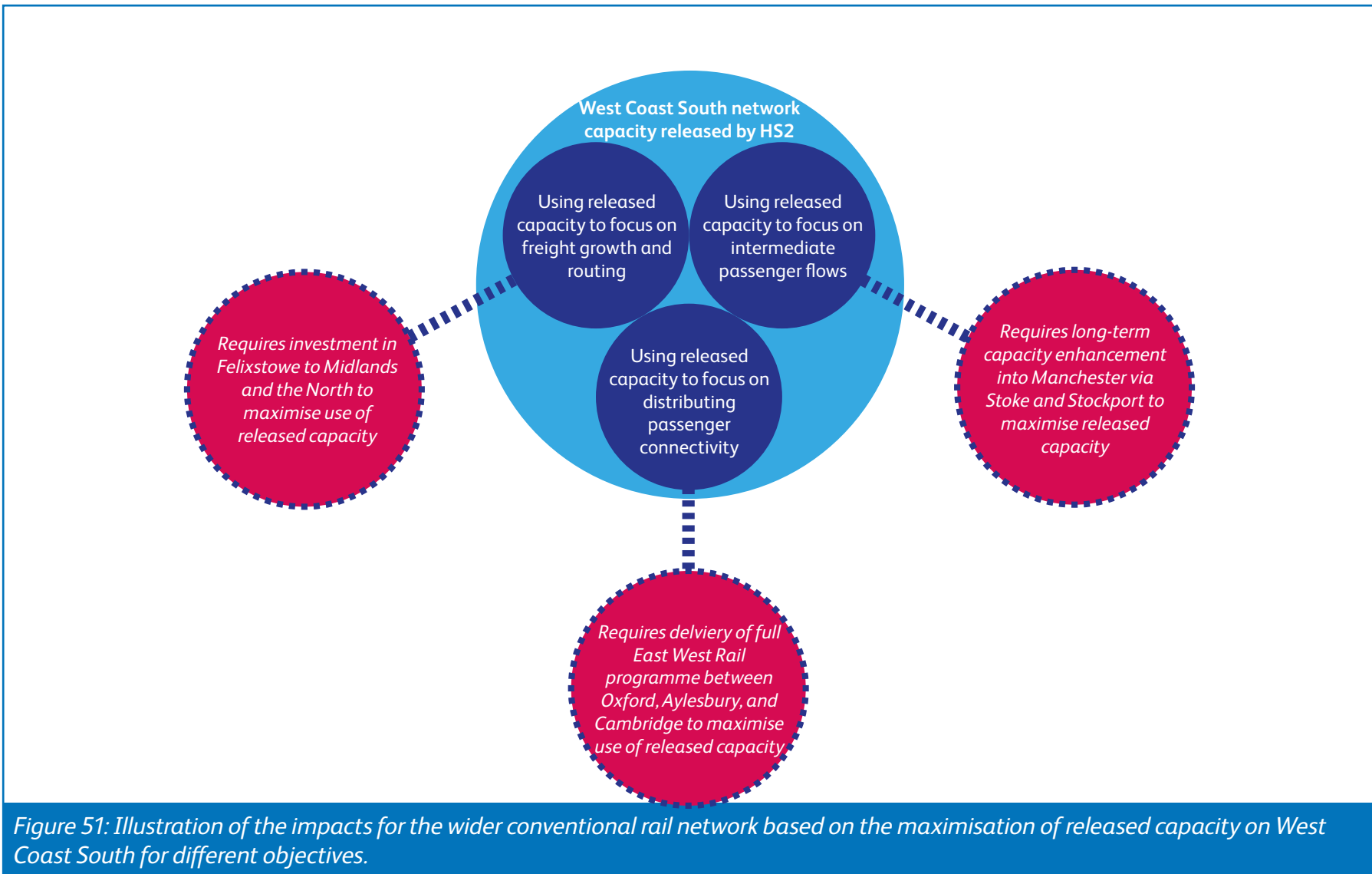

In all instances, maximising the use of released capacity on a single or specific combination of objectives resulted in the need to consider investment outside the WCSSA scope area to provide sufficient capability to fully realise prospective benefits. This does not mean that there is a specific dependency with investment elsewhere on the network to achieve any improvement in freight or passenger service on West Coast South post-HS2, but rather that further work will be required should maximising the use of released capacity for a given objective inform the post-HS2 timetable change.

The results of the scenario testing show what options are available to maximise the use of released capacity for a specific goal or policy objective. A determination on government policy and objectives for rail can then be informed by the results of the scenario testing and the associated trade-offs and dependencies highlighted in this work. Providing that the requirements laid out in the Planning Principles articulated in section 5 of this report are used as a basis for development of the post-HS2 West Coast South timetable, then incremental changes to the train service can be made which reflect future policy preferences in a logical and strategic manner as wider constraints are resolved.

Further strategic assessment must be undertaken to detail more precisely what is required to maximise utilisation of released capacity on areas of the network which were out of scope for this study. A summary of relevant future workstreams is provided in the next steps in section 7.

Maximisation of the benefits associated with released capacity will require a policy determination on a preferred objective or focus.

As a starting point, the Planning Principles laid out in Section 4 of this report should be used as a foundation for development of the released capacity train service and timetable change.

Adopting these principles does not necessarily drive a need for further infrastructure beyond that planned by HS2 and will provide a credible baseline which ensures strategic fit with long-term changes to the conventional network infrastructure and leaves open the possibility of further incremental improvements in future.

Infrastructure Enhancement Priorities

Section 5 of this report demonstrated the extent to which infrastructure intervention could unlock additional train services and mitigate some of the trade-offs identified in the released capacity train plans. This was achieved by assuming infrastructure change to unblock major constraints in each scenario and assessing the material change to the train service for each option.

This process has helped identify what interventions should be prioritised within a given scenario, as well as providing a comparison across all scenarios which enables a cross-scenario prioritisation for each enhancement option based on:

- The extent to which the enhancement delivers a material improvement in passenger connectivity or freight uplift, not just an improvement in on-train capacity (i.e. number of seats),
- The benefit the enhancement generated in terms of service uplift and protection of performance compared to the likely scale and cost of the infrastructure required,
- The extent to which a given enhancement option generated an impact across scenarios, with higher priority ascribed to those which generated a benefit in the greatest number,
- The potential that a given enhancement may have in exacerbating known capacity constraints elsewhere, with priority given to ‘no regrets’ enhancements which require only the infrastructure outlined in the assumptions to use,
- The potential for a given enhancement to generate a benefit to the wider network ahead of introduction of high-speed services as well as in the long-term.

Table 43 overleaf shows the impact of all infrastructure enhancement options tested in this work across all scenarios, summarising all the results described in Section 6 of this report. The table should be used as an assessment of priority, helping to identify where long-term investment in the conventional infrastructure is most likely to generate a train service benefit with long-term strategic fit. The assessment table is colour coded to show:

Enhancements which had a major positive impact in delivering against the given scenario's objectives through change in the train service.

Enhancements which had a minor or qualified impact in delivering against the given scenario's objectives through change in the train service.

Enhancements which had a negligible or performance-only impact in the given scenario.

Enhancements which did not generate a material benefit in the given scenario.

Where a train service change required more than one option in a given scenario, it has been captured in *standout* text.

For the purposes of the assessment, services which could be accommodated from the Cambridge direction are assumed to require a northeast chord at Bletchley to provide the most flexible and direct route. There may be interim options to reverse passenger services at Bletchley, but this is not an optimal long-term solution for either passenger or freight operations.

Table 43: WCSSA cross-scenario infrastructure intervention prioritisation assessment.

Enhancement Option	Scenario 1 Freight Focus	Scenario 2 Intermediate Markets	Scenario 3 East West Connectivity	Scenario 4 New Connections
Bletchley - Milton Keynes North Connection	<p><i>Potential performance and resilience benefit for through-running freight via EWR.</i></p> <p>[requires Bletchley NE Chord]</p>	<p>+2tph Aylesbury-Milton Keynes</p> <p>+2tph Cambridge-Milton Keynes [requires Bletchley NE Chord]</p> <p>+2tph London-Milton Keynes</p> <p><i>+performance/ resilience at MKC</i></p>	<p>+1tph Class 4 Freight Felixstowe-Crewe [requires Bletchley NE Chord]</p> <p>+1tph Class 4 Freight London-Daventry</p> <p><i>+performance/ resilience at MKC</i></p>	<p>+1tph Aylesbury-Milton Keynes</p> <p>+2tph Cambridge-Milton Keynes [requires Bletchley NE Chord]</p> <p>+extension 1tph Oxford-Northampton</p> <p><i>+performance/ resilience at MKC</i></p>
Bletchley - Milton Keynes 6-track	<p>+2tph Aylesbury-Milton Keynes</p> <p>+2tph Cambridge-Milton Keynes [requires Bletchley NE Chord]</p> <p>+performance/ resilience at MKC</p>	<p>+2tph Aylesbury-Milton Keynes</p> <p>+2tph Cambridge-Milton Keynes [requires Bletchley NE Chord]</p> <p><i>+performance/ resilience at MKC</i></p> <p><i>Latent capacity for freight.</i></p>	<p>+performance/ resilience at MKC</p>	<p>+1tph Aylesbury-Milton Keynes</p> <p>+2tph Cambridge-Milton Keynes [requires Bletchley NE Chord]</p> <p>+performance/ resilience at MKC</p>

Table 43: WCSSA cross-scenario infrastructure intervention prioritisation assessment.

Enhancement Option	Scenario 1 Freight Focus	Scenario 2 Intermediate Markets	Scenario 3 East West Connectivity	Scenario 4 New Connections
Bletchley - Milton Keynes 5-track	+1tph Aylesbury-Milton Keynes <i>+performance/ resilience at MKC</i>	+2tph Aylesbury-Milton Keynes +2tph Cambridge-Milton Keynes [requires Bletchley NE Chord] <i>+performance/ resilience at MKC</i>	+performance/ resilience at MKC	+performance/ resilience at MKC
Bletchley Northeast Chord	+1tph Class 4 Freight Felixstowe-Crewe +2tph Cambridge-Milton Keynes [requires Bletchley- Milton Keynes 6-track]	+2tph Cambridge-Milton Keynes [requires any additional track options Bletchley-Milton Keynes]	+2tph Cambridge-Milton Keynes +1tph Class 4 Freight Felixstowe-Crewe +1tph Class 4 Freight Felixstowe-Crewe [requires Bletchley-Milton Keynes North Connection]	+1tph Class 4 Freight Felixstowe-Crewe +2tph Cambridge-Milton Keynes [requires Bletchley- Milton Keynes 6-track]
Colwich/ Rugeley North Junctions Remodelling	<i>No material benefit identified. Potential +performance.</i>	+1tph Walsall-Stafford <i>+performance/ resilience through reduced transition times</i>	+1tph Walsall-Stafford <i>+performance/ resilience through reduced transition times</i>	No material benefit identified. Quantum reduced by constraints further south

Table 43: WCSSA cross-scenario infrastructure intervention prioritisation assessment.

Enhancement Option	Scenario 1 Freight Focus	Scenario 2 Intermediate Markets	Scenario 3 East West Connectivity	Scenario 4 New Connections
Coventry Remodelling	<i>No material benefit identified. Potential +performance.</i>	No material benefit identified.	+2tph London-Northwest via Coventry/Nuneaton <i>Required when taking Coventry corridor long-term into account.</i>	+2tph London-Northwest via Coventry/Nuneaton <i>Required when taking Coventry corridor long-term into account.</i>
Nuneaton Remodelling	<i>No material benefit identified. Potential +performance.</i>	No material benefit identified.	+2tph London-Northwest via Coventry/Nuneaton <i>Required when taking Coventry corridor long-term into account.</i>	+2tph London-Northwest via Coventry/Nuneaton <i>Required when taking Coventry corridor long-term into account.</i>
Weedon Fast Line Loops	+1tph Class 4 Freight Felixstowe-Crewe [requires Bletchley-Milton Keynes 6-track and Bletchley NE Chord] <i>Only Down direction required.</i>	No material benefit identified. Capacity for freight constrained elsewhere	No material benefit identified.	+1tph London-Liverpool [requires Bletchley-Milton Keynes North Connection] <i>Required in both directions.</i>
South Northampton 4-track Layout	No material benefit identified.	No material benefit identified.	No material benefit identified.	+1tph London-Northampton [requires Bletchley-Milton Keynes North Connection] <i>+performance/ resilience at MKC</i>

Some of the infrastructure options tested in this work generated greater material benefit across the collected range of scenarios than others. A key finding of this work is the need to address the capacity bottleneck created between Bletchley and Milton Keynes which was a constraint in all scenarios. Consequently, almost all the infrastructure options between Bletchley and Milton Keynes provided a train service change in each scenario. Importantly, these interventions were shown to generate additional flexibility which could be used for an uplift in both passenger and freight services, regardless of the structure of the train plan across the rest of the geographic scope.

Interventions at Colwich/Rugeley North Junction, Coventry, Nuneaton and options for passing loops on the fast lines via Weedon generally either provided a more limited benefit in relation to the scale of the infrastructure required or were not required in some scenarios. As such, they represent a set of possible infrastructure enhancements with long-term strategic fit but a lower priority than the Bletchley-Milton Keynes interventions.

The four-track layout assumed for the new South Northampton station generated a material train service change only in the New Connections scenario, demonstrating the extent to which the full range of new stations drove a wider reduction in capacity themselves. Given that this infrastructure option effectively mitigated a constraint imposed by the new stations it is recommended that further work to understand the strategic need for new stations in the Northamptonshire area is explored before any further development.

The results shown in Table 43 present the collected impacts of each enhancement across all scenarios tested. It provides a broad assessment of long-term strategic fit for each option and helps inform the relative priority for future investment. This is based purely on a post-HS2 baseline however, and therefore assumes that capacity has been released on the conventional network.

To help guide the prioritisation further, Table 44 shows each infrastructure option within a basic direction of travel of proposed enhancement schemes on the wider network including HS2 Western Leg London-Manchester and East West Rail. This secondary, qualitative assessment is provided to help determine the extent to which an infrastructure option identified in this work could deliver a benefit ahead of for example, HS2 Configuration State G. The table is colour coded to show:

Enhancements which could deliver a significant and material train service change in the given network configuration.

Enhancements which could deliver an improvement in network capability or performance in the given network configuration.

Enhancements which would not have an impact on the train service in the given network configuration due to dependencies elsewhere.

Table 44: WCSSA direction of travel assessment of infrastructure enhancements.

*service uplifts at HS2 Phase 2B (Crewe-Manchester) may require further conventional network enhancement in the Northwest, subject to further strategic analysis.

	2022 → 2050						
Enhancement Option	December 2022 Timetable (pre-HS2 network baseline)	EWR Connection Stage 1 (Oxford-Bletchley)	HS2 Config. State G (Euston-Crewe)	EWR Connection Stage 2.5 (Aylesbury-Claydon Jn.)	EWR Connection Stages 2 and 3 (Bletchley/Bedford-Cambridge)	HS2 Phase 2B Western Leg (Crewe-Manchester)	Felixstowe to Midlands and the North
Bletchley-Milton Keynes North Connection	No deliverable benefit	+performance/ flexibility	+performance/ flexibility	+service uplift +performance / flexibility	+service uplift +performance / flexibility		+service uplift +performance / flexibility
Bletchley-Milton Keynes 6-track	No deliverable benefit	+performance/ flexibility	+performance/ flexibility	+service uplift +performance / flexibility	+service uplift +performance / flexibility		
Bletchley-Milton Keynes 5-track	No deliverable benefit	+performance/ flexibility	+performance/ flexibility	+service uplift +performance / flexibility	+service uplift +performance / flexibility		
Bletchley Northeast Chord	No deliverable benefit	No deliverable benefit	No deliverable benefit	No deliverable benefit	+service uplift		+service uplift
Colwich/Rugeley North Junctions Remodelling	+performance/ journey time	+performance/ journey time	+service uplift				

Table 44: WCSSA direction of travel assessment of infrastructure enhancements.

*service uplifts at HS2 Phase 2B (Crewe-Manchester) may require further conventional network enhancement in the Northwest, subject to further strategic analysis.

	2022						2050
Enhancement Option	December 2022 Timetable (pre-HS2 network baseline)	EWR Connection Stage 1 (Oxford-Bletchley)	HS2 Config. State G (Euston-Crewe)	EWR Connection Stage 2.5 (Aylesbury-Claydon Jn.)	EWR Connection Stages 2 and 3 (Bletchley/Bedford-Cambridge)	HS2 Phase 2B Western Leg (Crewe-Manchester)	Felixstowe to Midlands and the North
Coventry Remodelling	No deliverable benefit	No deliverable benefit	+service uplift [scenario specific] + Performance			+potential service uplift* [scenario specific]	
Nuneaton Remodelling	No deliverable benefit	No deliverable benefit	+service uplift [scenario specific] + Performance			+potential service uplift* [scenario specific]	
Weedon Fast Line Loops	No deliverable benefit	No deliverable benefit	+service uplift [scenario specific]				+service uplift [scenario specific]
South Northampton 4-track layout	No deliverable benefit	No deliverable benefit	+service uplift [scenario specific]				

Interventions comprised of additional track between Bletchley and Milton Keynes could be utilised by passenger and freight services which are planned to enter into service from 2024 following delivery of East West Rail Connection Stage One. The additional infrastructure would provide a segregated network for passenger services operating between Oxford and Milton Keynes ahead of HS2, banking performance benefits as well as providing much greater planning flexibility by decoupling East West Rail services from those operating on the heavily utilised West Coast Main Line. The additional infrastructure could be used to generate some incremental benefit at any point after 2024 once East West Rail infrastructure has been delivered between Oxford and Bletchley before its full utilisation following HS2 and subsequent East West Rail connection stages.

This is not the case however, for the Bletchley northeast chord option which can only be routinely utilised following completion of later East West Rail connection stages to Cambridge. Consequently, it is recommended that a northeast chord at Bletchley is - as a minimum - passively provided for in any of the Bletchley-Milton Keynes options should they be delivered separately and that options are developed holistically as a package.

Most of the WCSSA enhancement options identified required at least HS2 Configuration State G infrastructure. It is the associated release of conventional network capacity which permitted a wider distribution of passenger service connectivity - notably intercity-type services via Coventry and Nuneaton - as

well as the potential for routing freight via the fast lines. The need to protect long-distance, intercity journey times via West Coast South ahead of HS2 means that the enhancement options identified at Coventry, Nuneaton and fast line freight loops could not be utilised (at least for service improvements via West Coast South) until HS2 is in operation.

The Colwich / Rugeley North Junctions enhancement could deliver a benefit at all points in the direction of travel outlined. This is based on the assumed impact to headline journey times that would be accrued by providing for fast transit times through the junction for long-distance, intercity West Coast services. Given the scale of the required intervention and the limited identifiable impact across scenarios this option was considered a lower priority. Further work could be undertaken to progress doubling of Rugeley North Junction with raised turnout speeds to permit extension of Chase Line services, but this requires the capacity released by HS2 at configuration state G as a starting point.

The overarching infrastructure enhancement option summary is shown in Table 44. This assessment will now form the basis of Network Rail's advice on investment in any major conventional infrastructure on West Coast South route and will be used to guide further development work accordingly.

The outline scope, requirements and order of magnitude costs for each of the recommended enhancement packages is provided in the following pages.

The enhancement options identified in this report between Bletchley and Milton Keynes should be the immediate priority for further development.

This is because they generated a significant material impact and benefit across all scenarios tested and represent a 'no regrets' investment where incremental benefits could be achieved or ramped up over time.

The enhancement options identified at Coventry, Nuneaton, Colwich / Rugeley Junctions and Loops via Weedon offer strategic fit but should be explored separately.

This is because these options generated a material impact and benefit in some scenarios only, or the extent of the benefit identified was limited given the potential scope of the work. There may also be wider network dependencies for these enhancements which drive the need for further analysis incorporating local service changes in the West Midlands.

Strategic fit cannot be assured for any development of new stations at Daventry and South Northampton, and associated infrastructure layouts, without undertaking a wider assessment of new stations needs first given the impact on wider network capability.

Table 45: WCSSA enhancement option summary table. Table incorporates tested, untested and unrequired options identified as part of this work. Assessment of strategic fit is current and should be revisited subject to long-term capacity enhancements on the wider network and technological change.

Enhancement Option	Has Strategic Fit?	Priority to Develop	Required to develop further
Bletchley - Milton Keynes Fifth Track	Yes	High	Should be developed further as a package of interventions
Bletchley - Milton Keynes Sixth Track	Yes	High	
Milton Keynes Northern Connection	Yes	High	
Bletchley Northeast Chord	Yes	High	
Coventry Station Remodelling	Yes	Medium	Should be developed further as a package. Requires further work to understand impacts on local services to establish full benefits
Nuneaton Station Remodelling	Yes	Medium	
Weedon Fast Line Freight Loops	Yes	Medium	Requires determination on post-HS2 train service structure and residual fast line capacity.
Colwich/Rugeley North Jn Remodelling	Yes	Low	More detailed technical assessment of journey time and performance impact required but could be progressed in line with recommendations of this document.
Northampton Linespeed Improvement	Yes	Low	
Stafford South Jn Doubling	Yes	Low	
Trent Valley Linespeed Improvement	Yes	Low	
Hanslope Jn Remodelling	Yes	Low	
South Northampton Station Four Track layout	No	n/a	
London - Rugby Slow Line Resignalling	No	n/a	Reduced headway should be delivered through planned ETCS roll out.
Milton Keynes - Northampton Additional Track	No	n/a	Should not be progressed until long-term strategic analysis on the wider network demonstrates a credible need, and that unlocked train paths can be utilised in full.
Rugby-Nuneaton Additional Track	No	n/a	
Colwich - Stafford TV Jn Additional Track	No	n/a	
Colwich Junction Grade Separation	No	n/a	
Hanslope Junction Grade Separation	No	n/a	
	No	n/a	

Priority Enhancement Package: Bletchley to Milton Keynes

The route section between Bletchley and Milton Keynes was identified as a key constraint in all scenarios, driven by the need to plan passenger and freight services from East West Rail as well as those on the trunk West Coast Main Line. The most efficient way to integrate and support these aspirations is to segregate West Coast and East West Rail traffic through additional track from Bletchley and new platforms at Milton Keynes Central. This improved wider network capability whilst supporting Planning Principle B in centring Milton Keynes as a ‘hub’, maximising the opportunity for interchange on the wider network and catering for city’s forecasted growth.

The results of the concept train plan work demonstrated that while a five-track option generated significant utility for additional passenger services, six-tracking was required to enable sufficient flexibility to include uplifted freight. This is because a fifth-track would create a single line section for East West Rail traffic between Bletchley and Milton Keynes, significantly limiting the ability to plan all required traffic in both directions. The engineering feasibility undertaken suggests that the additional cost associated with a sixth-track option is largely confined to the required earthworks, track and signalling, avoiding a need for land take or bridge reconstruction.

A Milton Keynes ‘northern connection’ option was also considered which provide new through platforms on the eastern side of Milton Keynes Central instead of terminal bay platforms



Figure 52: Scope area for highest priority infrastructure options identified as part of WCSSA, including Bletchley-Milton Keynes additional track and platforms, Milton Keynes Northern Connection and Bletchley Northeast Chord. Satellite imagery copyright ARCGIS, Esri, Maxar and Earthstar Geographics.

on the additional two tracks. This was found to generate the maximum flexibility to plan additional freight via East West Rail as well as extension of East West Rail services beyond Milton Keynes by largely segregating East West Rail and West Coast South traffic through the station itself. Additional cost would be incurred by providing through platforms at Milton Keynes Central in lieu of bays, as well providing a connection to the slow and fast lines immediately north of the station. This is due to the complex signalling arrangements on approach to the station at Milton Keynes North junction which would need to be restructured to accommodate a new set of turnouts. Provision of a flat double junction was found to be feasible without reconstruction of the A509 road overbridge immediately to the north of Milton Keynes Central which could significantly increase costs if required.

A northeast chord at Bletchley would provide direct connections for east-bound services but the results of the scenario testing highlight the impact this may have on main line capability without further infrastructure enhancement. It is recommended that a northeast chord is developed alongside options for additional track per the full package of works shown in Figure 53. This is on the grounds that service extensions utilising a chord do not compromise main line capacity and that sufficient capability is provided to plan more than 2tph passenger services on to West Coast South in future.

It is recommended that further development is undertaken based on the full requirements illustrated in Figure 53. The cost

range provided is based on early maturity engineering feasibility and shows only a base cost for the assumed infrastructure. These costs will require further evaluation, as well as capturing costs associated with risk and delivery should the enhancements be progressed per the established business case process.

Table 46: Bletchley - Milton Keynes Northern Connection and Bletchley Northeast Chord: Train service changes by scenario

Freight Focus	+2tph Aylesbury - Milton Keynes +2tph Cambridge - Milton Keynes
Intermediate Markets	+2tph Aylesbury - Milton Keynes +2tph Cambridge - Milton Keynes +2tph London Euston - Milton Keynes
East West Connectivity	+2tph Class 4 Freight via EWR <i>+Major performance impact</i>
New Connections	+1tph Aylesbury-Milton Keynes +2tph Cambridge - Milton Keynes +1tph Clapham Jn - Milton Keynes +1tph Oxford - Northampton
Order of magnitude of cost	£350-500m
Priority for development	High

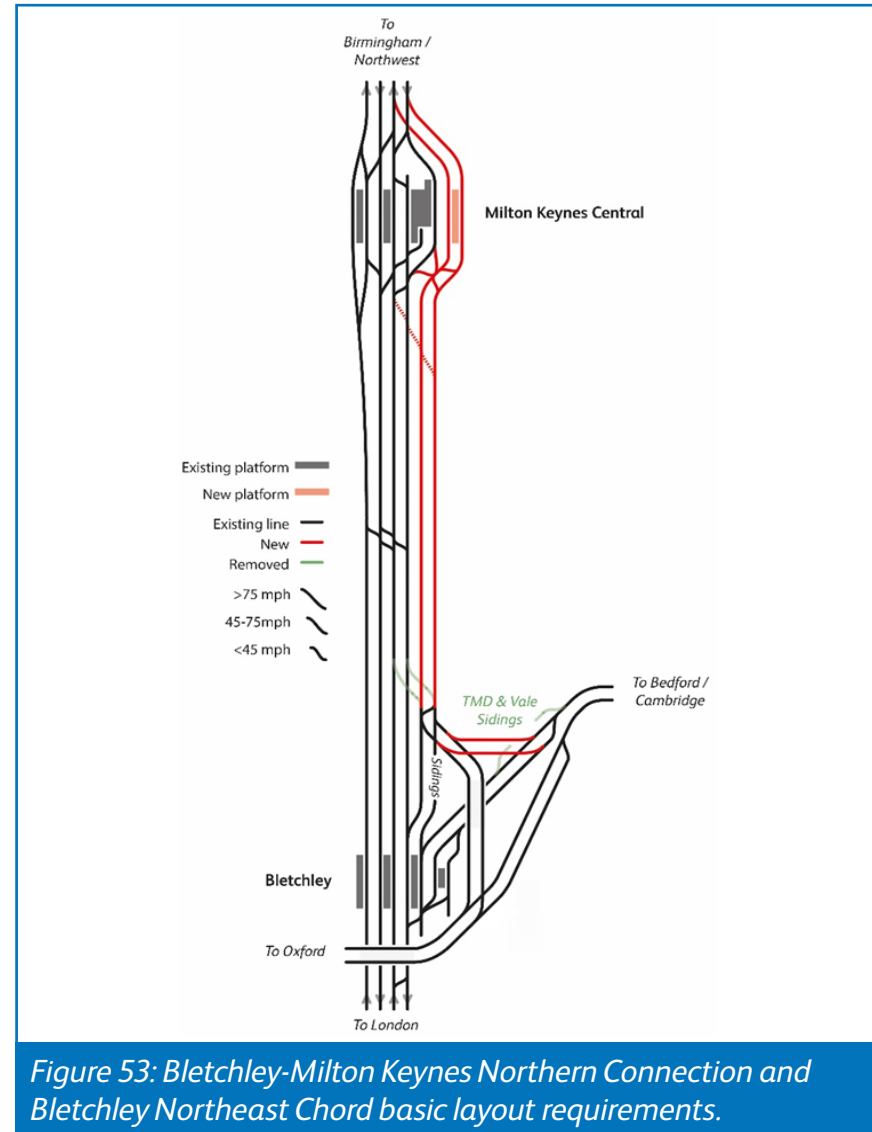

Figure 53: Bletchley-Milton Keynes Northern Connection and Bletchley Northeast Chord basic layout requirements.

Enhancement Package: Coventry and Nuneaton

In the East West Connectivity and New Connections scenarios priority was given to intercity-type train services operating between London and the Northwest via Coventry and Nuneaton. The two train per hour service was tested on the grounds of providing an improved 15-minute frequency for intercity trains between Coventry and London, as well as supporting improved direct connections between Coventry, the Trent Valley and the Northwest. It is recommended that the Coventry and Nuneaton infrastructure package be developed further if widening connectivity is a priority post-HS2.

The released capacity train plans which incorporated these train movements were compliant on the existing infrastructure, however it was not possible to sufficiently assure performance or capability flexibility should an uplifted level of local and interregional service be provided in addition. Infrastructure intervention would be required to ensure that the train service options identified in the East West Connectivity and New Connections scenarios could be reliably planned without compromising capability on West Coast Main Line or on the local West Midlands network.

At Nuneaton an extended platform one, as well as doubling and relocation of the approach via Ashby Junction, should be developed as a minimum. This ensures flexibility for parallel moves into and out of the station from the West Coast Main Line, as well as capability for terminating local services from



Figure 54: Scope area for Coventry and Nuneaton enhancement package interventions, comprised of Coventry and Nuneaton station remodelling works. Satellite imagery copyright ARCGIS, Esri, Maxar and Earthstar Geographics.

the Coventry direction. Relocation of Ashby Junction with doubled, higher-speed turnouts would enhance capability and performance by limiting the time taken by passenger services to cross the northbound main lines. Additional turnouts on the Leicester and flyover lines included in the scope below could be progressed separately to support the increased volume of freight movements in each scenario. Each of these elements must be tested per the established business case process, though it is recommended that they are developed together to ensure the most efficient delivery and minimise disruption to the rail network.

At Coventry, wholesale track remodelling should be developed further based on the layout shown in Figure 55. This would require the rearranging of turnouts from the east to the west end of the station, permitting a more uniform speed profile through the station and crucially, more rational platform operation and reduced signalling restrictions. It is essential that the 'normal' route for passenger services to/from the Rugby direction is via platforms 1 and 2, segregating them from passenger services between the West Midlands and Leamington which operating accordingly via platforms 3 and 4. This would be a major change to today's layout where the normal route is through platforms 1 and 3, forcing additional crossing moves for services planned off the main lines and on to the Bedworth lines.

Both sets of interventions would provide for sufficient track capacity to reliably plan a 2tph intercity-type service between Coventry and Nuneaton. The Bedworth lines are however, currently unelectrified with a linespeed of 45mph.

An electrification or linespeed project could generate decarbonisation and fleet benefits in addition to reducing journey times for non-stop services planned between Coventry and Nuneaton. In either case, delivery would affect train timings for this line of route. As with all major interventions identified in this work, a replanned train service would be required to identify the full range of benefits associated with any enhancement scheme.

Table 47: Coventry and Nuneaton Remodelling: Train service changes by scenario

Freight Focus	<i>+Performance impact</i>
Intermediate Markets	<i>+Performance impact</i>
East West Connectivity	+1tph London Euston-Crewe (via Coventry and Nuneaton) +1tph London Euston-Crewe (via Coventry and Nuneaton)
New Connections	+1tph London Euston-Crewe (via Coventry and Nuneaton) +1tph London Euston-Crewe (via Coventry and Nuneaton)
Order of magnitude of cost	£100-£200m
Priority for development	Medium

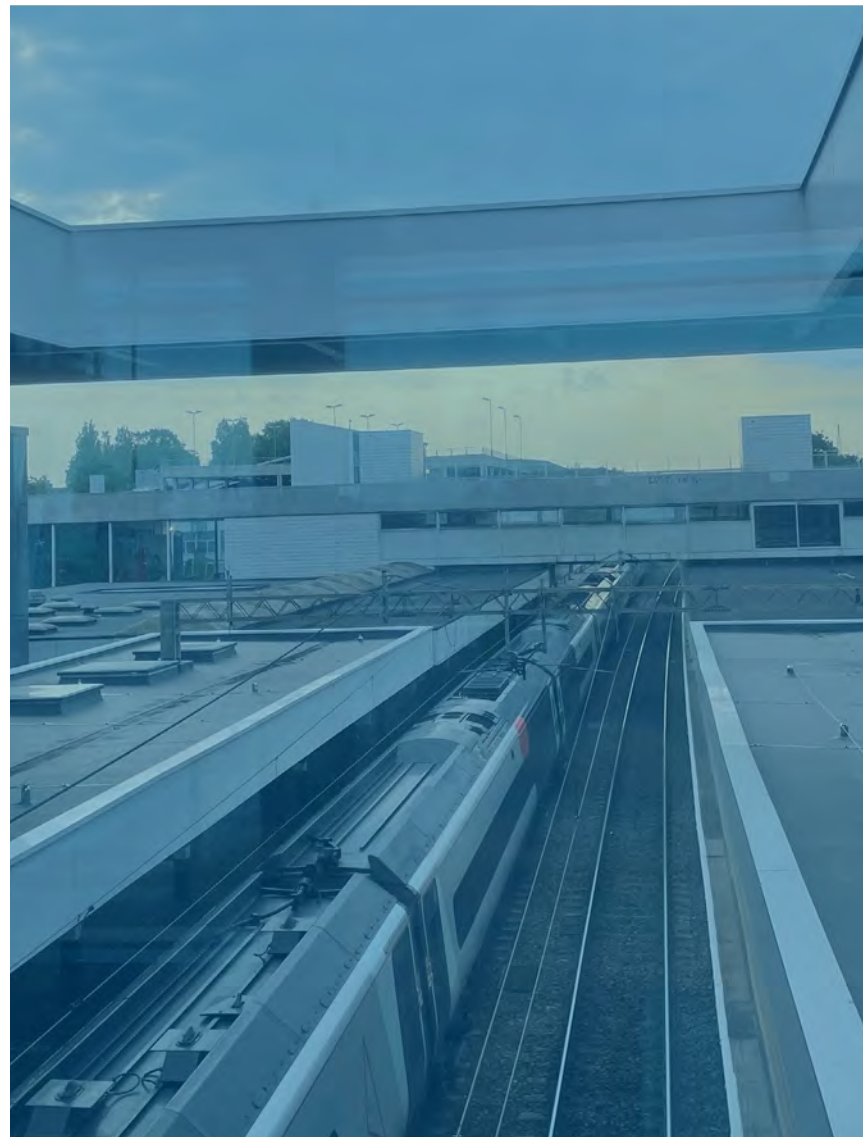

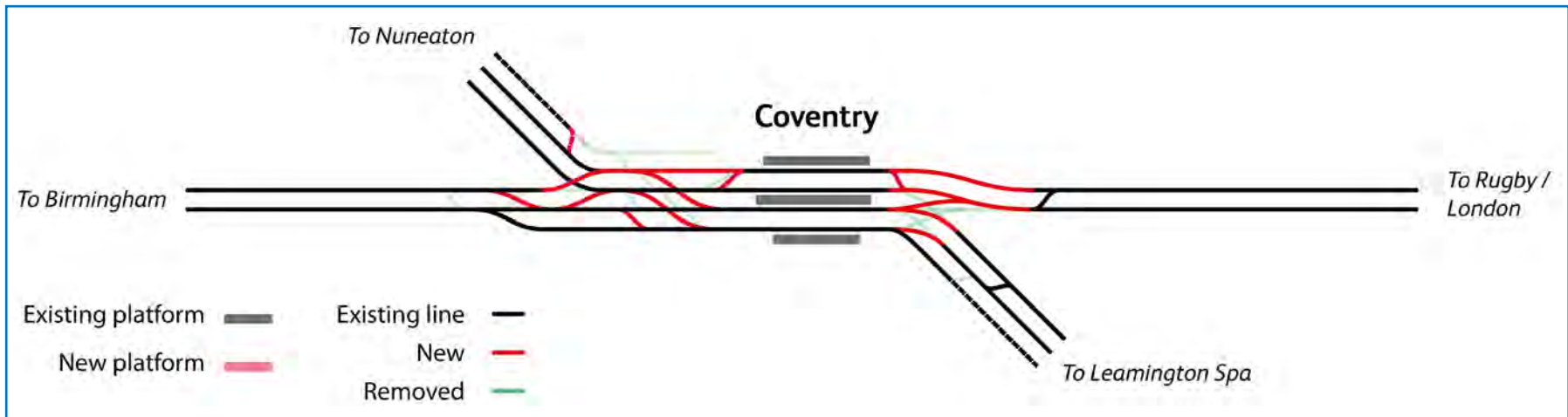

Figure 55: Coventry remodelling basic layout requirements.

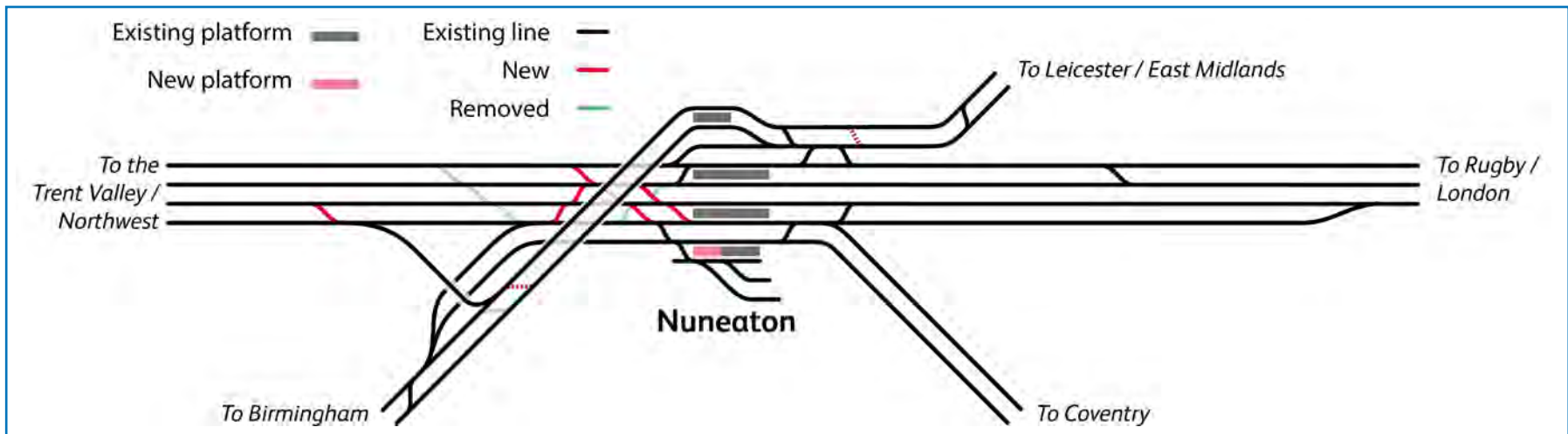

Figure 56: Nuneaton remodelling basic layout requirements.

Enhancement Package: Colwich / Rugeley North Junction

In both the Intermediate Markets and East West Connectivity scenarios the ability to extend local services from Walsall via the Chase Line to Stafford and Stoke-on-Trent was constrained by junction capacity at Rugeley North and Colwich.

The immediate solution required doubling the existing Rugeley North junction and raising junction speeds to at least 40mph (from today's 20mph). A second Chase Line platform as well as doubling the northern end of the Chase Line would provide maximum flexibility and ensure that services from Birmingham and Walsall could extend on to the main line utilising the capacity released by HS2.

The increased quantum of crossing moves from the Chase Line were found to exacerbate known constraints around Colwich Junction where the four-track main line diverges into the lines to Stafford and the lines to Stoke-on-Trent. The existing layout presents a potential constraint due to the slow speed turnouts, the associated restrictive signalling on approach, and the proximity to a tight curve on the lines to Stoke-on-Trent which forces trains routed that way to slow down to 45mph through the junction.

The enhancement option assessed and shown in Figure 58 in this work is a 'do maximum' option in which Colwich and Rugeley Junctions are combined further south away from the Stoke lines curve. This maximises the ability to plan movements

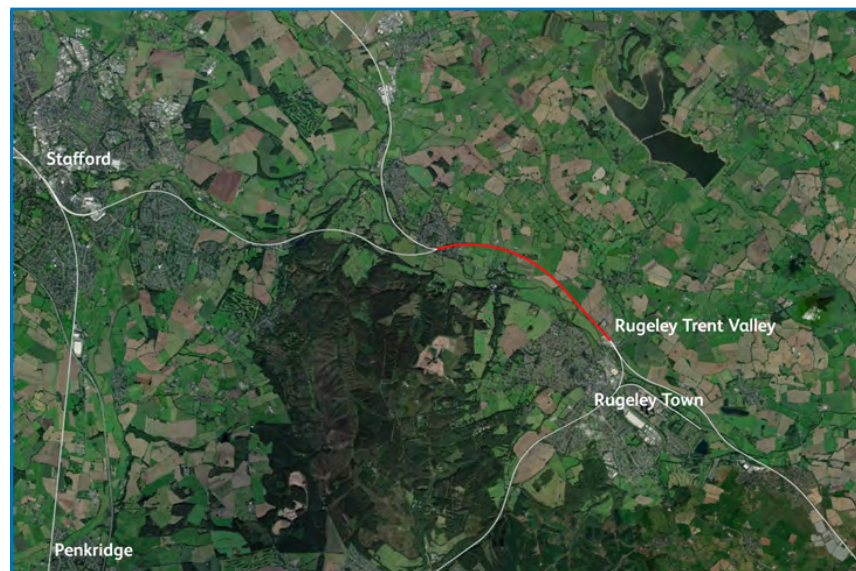

Figure 57: Scope area for the Colwich/Rugeley North Junctions remodelling enhancement option. Satellite imagery copyright ARCGIS, Esri, Maxar and Earthstar Geographics.

Table 48: Colwich/Rugeley North Junction Remodelling: Train service changes by scenario.

Freight Focus	<i>+Performance impact</i>
Intermediate Markets	+1tph Walsall-Stafford
East West Connectivity	+1tph Walsall-Stafford or Stoke
New Connections	<i>+Performance impact</i>
Order of magnitude of cost	£100-£200m
Priority for development	Low

to and from the Chase Line as well as protecting capacity and performance through provision of higher-speed turnouts and less restrictive signalling. Some journey time savings could also be realised by reducing the time required for passenger and freight services to transition through the junction.

This option also includes extension of bi-directional signalling from Lichfield providing much greater flexibility when operating a two-track regime on the main lines. Likewise, the option removes the fixed diamond crossing with a new layout which, as result of re-siting the junction further south, lengthens the approach to the Stoke lines curve. This means services can decelerate after transitioning through the junction and therefore limits the capacity impact for planning such movements. However, given the limited extent of the benefit identified across all scenarios it is recommended that this option is given a lower priority for further development. The existing layout was sufficient to achieve scenario objectives with the impact limited primarily to local Chase Line services. Doubling Rugeley North Junction could be considered separately, provided passive provision is made to re-site and combine with Colwich Junction in future.

The overarching layout would involve significant trackwork and slewing, reflected in the order of magnitude costs. This would need a strong identification of benefits to support as a major single enhancement scheme, something which could not be assured fully in this assessment given the level of detail provided in the scenario concept train planning work.

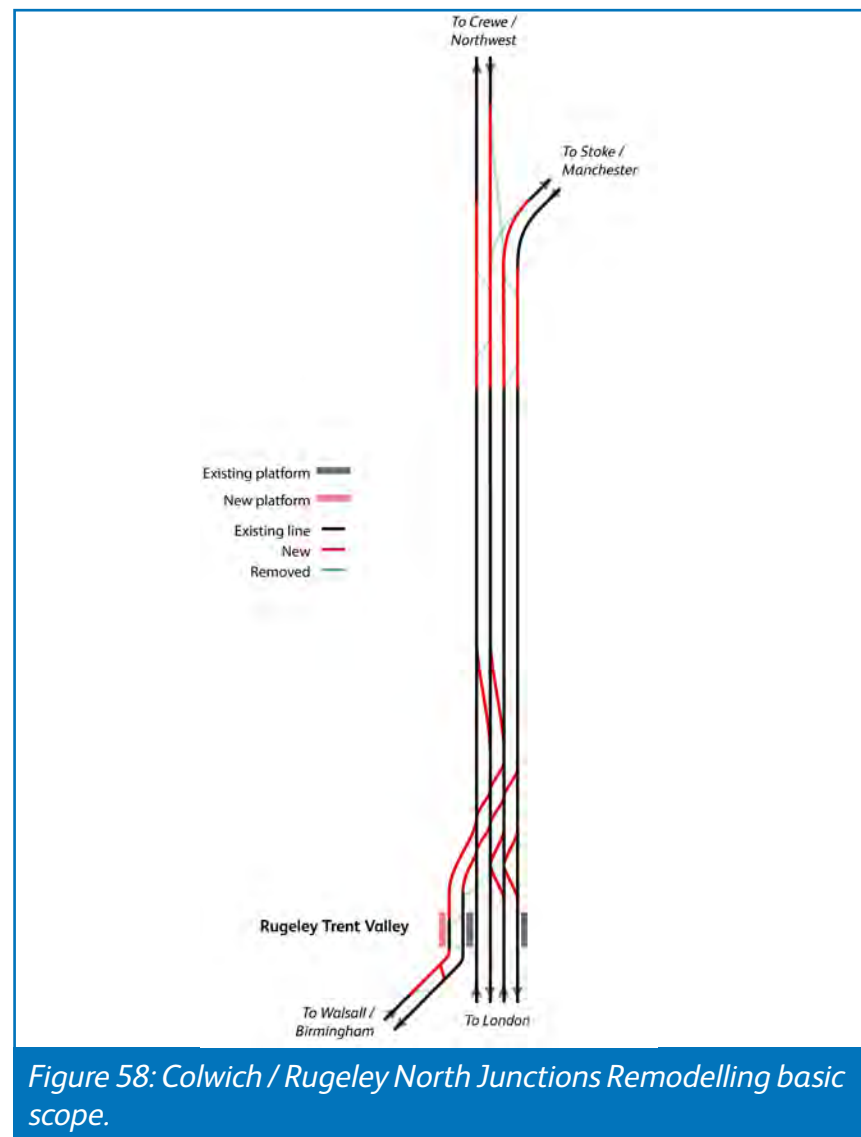

Figure 58: Colwich / Rugeley North Junctions Remodelling basic scope.

Enhancement Package: Weedon Fast Line Loops

Significant capacity remained available on the fast lines via Weedon between Hanslope Junction and Rugby in the Freight Focus, East West Connectivity and New Connections scenarios. As explained throughout section 6 of this report, this was variously the result of planning an uplift in freight via the slow lines, or an uplifted passenger service via Northampton. Assuming electric traction for freight, the testing undertaken in this work found that Class 4 freight services could take advantage of latent fast line capacity, providing a more direct routing between London and Birmingham or the Northwest, as well as more evenly spreading capacity utilisation between fast and slow lines. However, timings at both Hanslope Junction and Rugby limited the ability to provide compliant fast line freight paths and generated a consequent need for looping capability to hold freight in the area identified in Figure 59 (in the northbound direction in a Freight Focused scenario, and in both directions in the New Connections scenario).

As shown in the cross-scenario infrastructure assessment, utilisation of fast line loops for freight required resolution of the capacity constraint between Bletchley and Milton Keynes. As such this enhancement option is considered a lower priority due to the dependency on delivery of other infrastructure enhancements identified in this work.

No specific costs or engineering feasibility have been provided for this option given the uncertainty over the required scope



Figure 59: Scope area for fast line loops. Further work is required to determine the optimum position of loops in both directions, given the different results across freight and passenger-focused scenarios. Satellite imagery copyright ARCGIS, Esri, Maxar and Earthstar Geographics.



and location. In a freight focused scenario a loop in the down direction only, as close to Rugby as possible, was required due to the specific constraint associated with the Rugby-Nuneaton three-track section. In the New Connections scenario loops were required in both directions further south, closer to Daventry. The latter option would give the greatest improvement in network capability but specific requirements would depend on the composition of the post-HS2 train service, and whether this is used to deliver an additional freight path (per the Freight Focus scenario) or to relieve slow line capacity for passenger service (as in the New Connections scenario).

Further, proximity to the assumed location of a new station near Daventry could present an opportunity in delivery. This should however follow on from the stations needs assessment which has been identified as a required piece of further work ahead of any development of new stations in this area.

Untested Enhancement Options

The scenario-based approach adopted in this work focused deliberately on providing a wide-angle assessment of West Coast South route's strategic needs and priority options to resolve long-term constraints. As a consequence, there are some known enhancement options which did not emerge as requirements from the concept train planning work and so have remained untested.

In general, these enhancement options are of a smaller scale and so a material change to the train service could not be identified within the high-level scope of the work. They could, however, generate a benefit in the scenarios tested in this work but it will require further follow-on analysis to establish a case in full.

These options – shown in overview in Figure 60 - are assessed to have long-term strategic fit provided development of a case for each accounts for the long-term recommendations on train service and infrastructure made in this document.

Northampton Line Speed Improvements

The existing speed profile through Northampton Station is limited to 20mph for through movements. This has an impact for freight which much decelerate to 20mph on a descending gradient into Northampton, before then accelerating back up an ascending gradient.

Raising the speed profile to 40mph throughout the station area could be achieved by relaying track to a higher grade, generating a reduction in transit times between Hanslope and Hillmorton junction. A speed profile higher than 40mph is likely to trigger

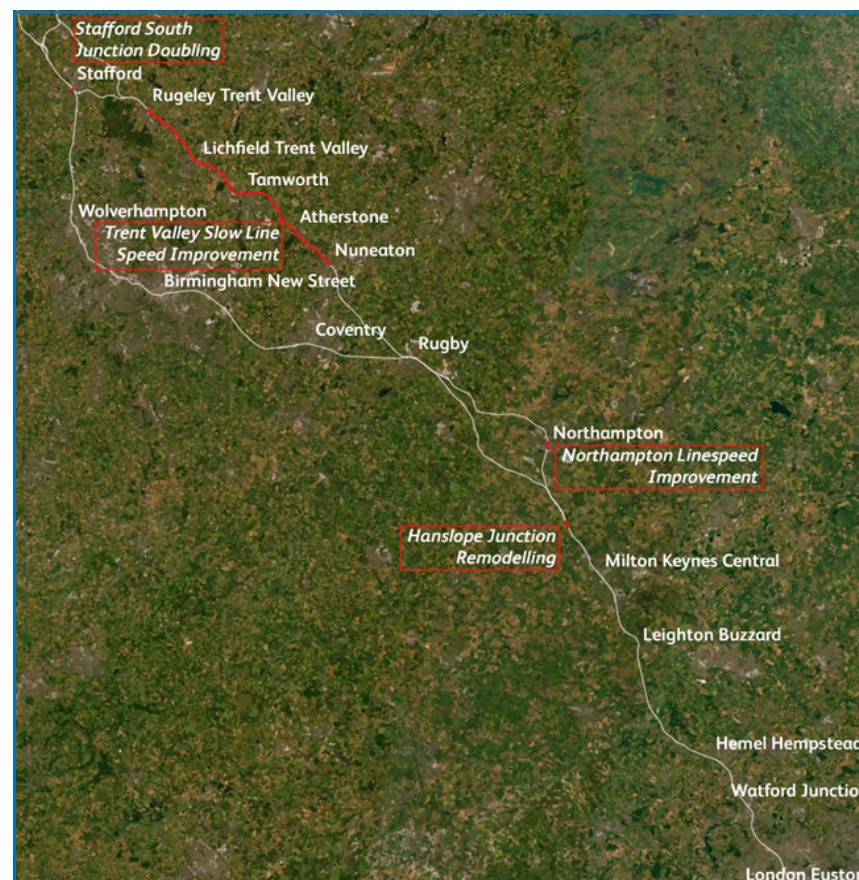

Figure 60: Scope areas for 'untested' enhancement options which could be developed further, in line with findings of the WCSSA testing.

very significant reconstruction works to the Earl Cowpers viaduct at which point the intervention is unlikely to generate sufficient benefit to cover the cost and consequent disruption.

Stafford South Junction Doubling

The existing layout at Stafford South Junction provides a single lead from the fast lines via Colwich through to the north and southbound goods loops. This means that it is not possible to plan simultaneous moves for freight into the goods loops without an additional crossover.

While this constraint did not emerge specifically in the testing undertaken in this work, it would provide much improved flexibility in a high-growth freight scenario as well as during perturbation.

Trent Valley Slow Line Speed Improvement

All the train plans produced as part of this work have been made compliant with existing timetable planning rules. As such, no linespeed improvement on the slow lines via the Trent Valley is required. However, all scenario train plans included increased calls at principal Trent Valley locations, meaning more intensive use of the existing slow lines. At present, there is a 12 mile section of route immediately north of Nuneaton station where the slow lines have a ruling linespeed of 75mph, before the linespeed rises to 110mph (125mph EPS) across all slow and fast lines.

An improvement in linespeed on the slow lines at this point on the network is likely to derive greater benefit in the post-HS2 period where slow line movements for passenger services between Nuneaton and Lichfield could become more frequent, as shown throughout the testing undertaken for this work. However, sufficient analysis would need to be undertaken to

establish a strong enough case, ensuring that any journey time savings or performance gains could be realised alongside an increased requirement to call intercity-type services at slow line only stations like Tamworth and Lichfield Trent Valley.

There is also a section track on the southbound slow line between Colwich Junction and just south of Rugeley Trent Valley station with a linespeed of 75mph. There may be further journey time benefits associated with raising the linespeed here, especially if a scheme to remodel Colwich Junction is progressed. It is also currently assumed that HS2 services to Macclesfield will join the conventional network on the slow lines south of Rugeley. Retaining the existing conventional linespeeds will reduce the utility of the high-speed turnouts provided at Handsacre Junction as a southbound train will only be able to begin accelerating beyond 75mph once it has reached the turnout.

Hanslope Junction Remodelling

Hanslope Junction did not emerge as a major constraint itself during the WCSSA testing. However, many of the released capacity and with infrastructure concept train plans generated in this work included an increase in the number of crossing moves between fast and slow lines at this location. Raising the speed of the existing turnouts (60mph) could mitigate capacity and performance impacts by minimising the time needed to plan transitional moves, and provide greater flexibility to route freight via the Weedon fast lines (subject to the requirements and findings of this report).

Unrequired Enhancement Options

The vast majority of scenario requirements could be achieved assuming some combination of the infrastructure options described in the cross-scenario prioritisation assessment. Some alternatives were considered throughout the testing process but were discounted for the following reasons:

- The options identified in the priority assessment sufficiently unlocked collected scenario requirements and achieved the scenario objectives,
- The scale of the alternative intervention is likely to be very significant and force an entire replan of the scenarios and train services tested,
- Alternative interventions beyond those identified in the priority assessment may exacerbate constraints out of scope for this work and therefore generate no benefit without significant investment elsewhere on the network first.

It is recommended that these ‘unrequired’ options are not developed further at this stage. Over the very long-term, should capacity constraints on the wider network be resolved through infrastructure enhancement or transformative technological change, these unrequired options could be reconsidered. Immediate development funding should be focused primarily on the enhancements identified in the cross-scenario priority assessment alongside further strategic analysis for other parts of the network including the Northwest, Manchester and the East West Rail route to Cambridge and Felixstowe.

London-Rugby Slow Line Re-signalling

Capacity on the slow lines between London and Northampton represented a constraint in all scenarios, driven by the need to plan additional freight alongside an improved frequency of local service to and from Euston.

A reduction in the planning headway from the current 4-minute to a 3-minute headway would create slow line capacity for higher local service frequency. Given the scale of the required intervention, it is recommended that delivery of a 3-minute planning headway is explored as part of Network Rail’s long-term deployment of European Traffic Control System (ETCS) digital signalling from the mid-2040s instead.

Milton Keynes to Northampton Additional Track

Slow line capacity between Milton Keynes and Northampton was found to be particularly constrained due to the long-term requirement to uplift passenger and freight services via Northampton in all scenarios.

This could be resolved through additional track between Milton Keynes and Northampton. However, this is not considered to be a useful intervention based on the very significant scale of the required infrastructure and the high likelihood that the required passenger and freight outcomes can be achieved by addressing the Bletchley-Milton Keynes area (per the options identified in this report) first.

Rugby to Nuneaton Additional Track

The freight focused scenario identified a specific constraint on the three-track section between Rugby and Nuneaton. The flight of Class 4 freight services had to be held on the northbound slow line ahead of the three-track section to let the following passenger flight pass. This presented limited on-track capacity for more than five of the Class 4 paths, essentially backing them up south to Rugby.

This constraint was resolved through provision of a northbound freight loop on the fast lines, making use of the latent fast line capacity made available by introduction of HS2 services. A more transformative option could involve four-tracking between Rugby and Nuneaton, however this would represent a significant engineering challenge given the proximity of the M6 motorway and the Oxford Canal. It would also require a complete replan to establish any benefits which are likely to be limited given the scale of the investment needed and the constraints identified elsewhere across West Coast South route, and at Crewe and Manchester.

Colwich Junction to Stafford Trent Valley Junction Additional Track

Previous work has suggested a case could be made to three or four-track the route section between Colwich Junction and Stafford Trent Valley Junction, especially in a scenario where there is a significantly increased number of freight movements on this route section post-HS2.

The testing undertaken in this workstream did not find that this intervention was required as more significant constraints emerged further south first, where the recommended infrastructure options identified were sufficient to generate a usable increase in capacity and capability. It is therefore recommended that additional track between Colwich and Stafford Trent Valley junctions is not progressed ahead of the options identified in the priority assessment.

Colwich Junction Grade Separation

The route section including Rugeley North and Colwich junctions emerged as a constraint in most scenarios tested in this work. This was due primarily to the requirement for additional local services planned from the Chase Line, driving a need to double and raise the linespeed of the existing Rugeley North junction.

A comprehensive at-grade solution to combine Colwich and Rugeley North junctions further south (away from the 45mph curve to the Stoke lines) and incorporate the extension of bi-directional signalling has been identified as part of this work. This was found to be sufficient to permit increased local services as well as generating a potential journey time and performance benefit through minimising transition speeds and signalling restrictions through the junction.

Grade separating the junction would of course have the greatest impact on performance and network capability by eliminating some crossing moves. However, given the potential scale of work required and limited achievable benefit, it is recommended that

this option is not progressed as it is unlikely to generate a usable benefit without major transformative interventions across the wider network (notably through Stoke-on-Trent, Stockport and into Manchester) occurring first.

Hanslope Junction Grade Separation

The scenario testing undertaken in this work identified the need for an increased number of crossing moves at Hanslope Junction. While this created a potential constraint, the testing found that all required train movements in all scenarios could be compliantly planned via the existing layout at Hanslope Junction. The infrastructure options tested between Bletchley and Milton Keynes generated sufficient planning flexibility to time more trains through the junction, meaning a major grade separation project was immediately required.

It is recommended instead that any enhancement is based on provision of high-speed turnouts at grade, minimising the transition times and signalling restrictions, per the suggested scope in the 'untested' options above.

This position may need to be revisited should a long-term reduction in slow line headways generate a credible need to plan more trains through the junction than has been identified in this strategic advice, or further development of options at Bletchley and Milton Keynes suggests a major strategic benefit for a grade separation project.

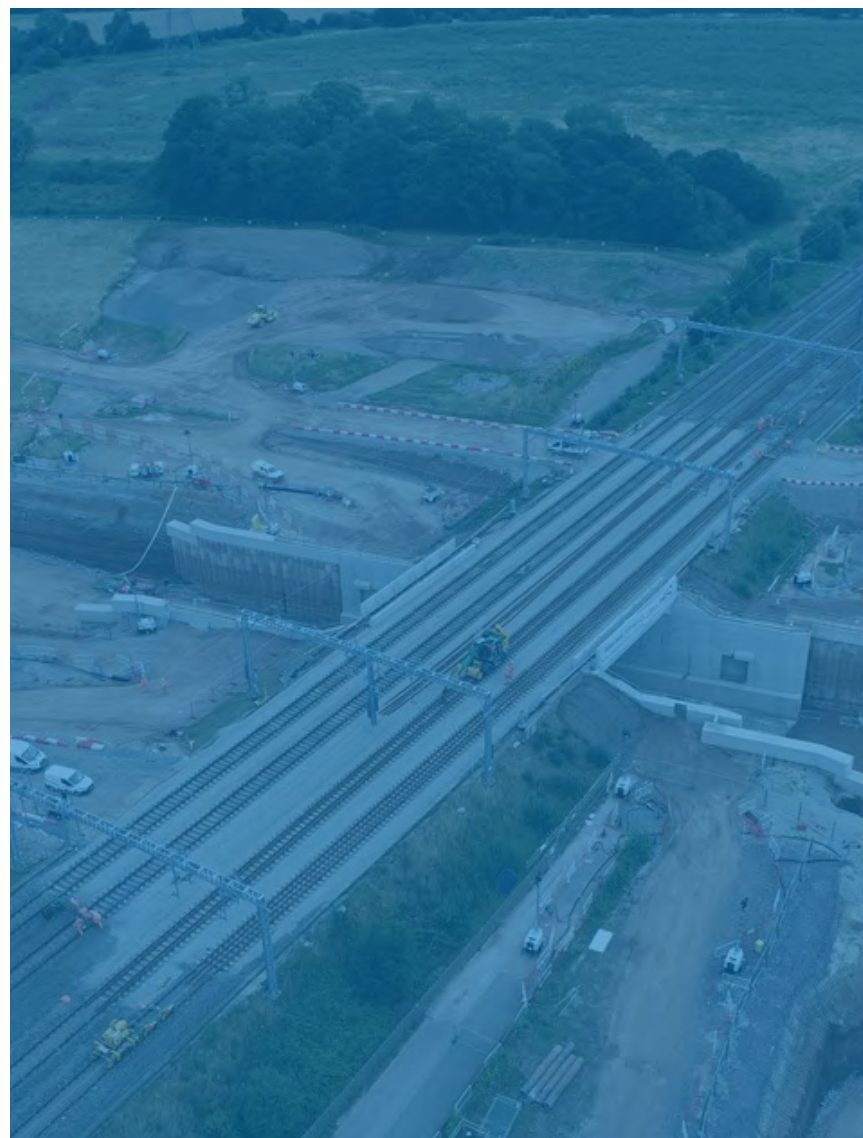

Operator Mapping and Rolling Stock Procurement

The Williams-Shapps Plan for Rail outlines the future structure of the rail industry, providing a strong emphasis on more strategic control and the creation of a guiding mind – Great British Railways (GBR) – to coordinate it. The plan also outlines the long-term vision for operation of the railway, including the replacement of rail franchises with passenger service contracts. Network Rail’s regional strategic advice – of which this document forms part for the West Coast South route – should be taken into account as decisions on future operations are taken directly by GBR. It is important that these decisions align with the advice provided in this document to ensure that the whole railway system works as effectively as possible.

While more detailed work will be undertaken as future passenger services contracts are created, WCSSA makes some basic recommendations on possible changes to the long-term operational structure of West Coast South route. They are made in line with the Planning Principles outlined in section 4, as well as the collective results of the scenario testing explained in section 5.

Changes to the Operator Map

All scenario train plans generated in this work have separated local service groups between London-Northampton and Northampton-Birmingham. As the results of the train planning work demonstrated, this did not compromise on a comparable

level of service for Long Buckby or the proposed new station at Rugby Parkway, nor did it preclude the opportunity for direct connectivity between Northampton and locations further north, except in a scenario assuming new stations at Daventry and South Northampton which are considered at this point to lack strategic fit.

The rationale for service group separation at Northampton is primarily operational, untying local services in the West Midlands from those running to and from London Euston. This generates long-term operational benefits, including:

- The ability for local interurban passenger services between Birmingham-Northampton and London-Northampton to be managed by different operators or business units, providing greater focus and responsiveness to a specific market.
- The potential to combine London-Northampton local services into a West Coast Main Line operator and provide a single operator at London Euston, potentially improving operational flexibility particularly in times of perturbation,
- The opportunity for more rational diagramming of services over the long-term matching rolling stock and platform lengths for London-Northampton services which are otherwise constrained by shorter platform lengths at local stations in the West Midlands.

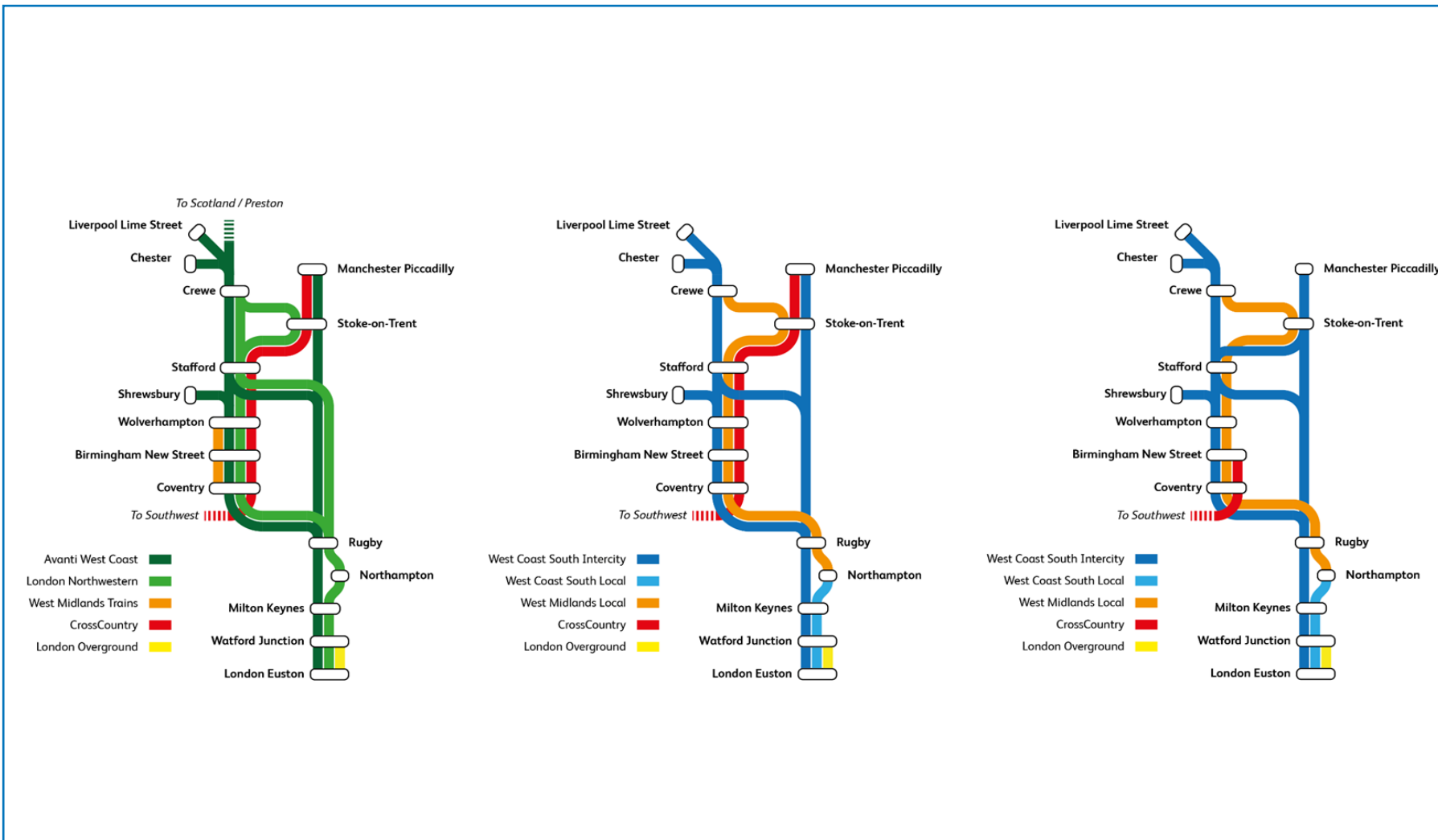

Figure 61: Pre-HS2 network baselines (December 2022 timetable) operator map (left), and potential rationalised post-HS2 operator maps (centre, right).

It is important to stress that the introduction of HS2 does not remove the need for intercity-type services to operate on the conventional network. As identified throughout this work, the effective use of released capacity will still require intercity markets to be served with fast, limited stop services.

The longest distance intercity West Coast services which operate today between London and the north of England and Scotland will be released by HS2. A more geographically confined West Coast South operator could be introduced combining residual intercity and interregional passenger services operating on the conventional network with local services operating along the Euston corridor to Northampton. This generates the potential to realise greater operational efficiencies, and responsiveness to West Coast South route markets as long-distance traffic is provided by the high-speed network.

Figure 61 shows the pre-HS2 network baseline operator map, based on the December 2022 timetable, on the left. Long-distance, intercity services operate alongside local and interregional services between London and the West Midlands.

The proposed post-HS2 operator map shown in the centre diagram shows a West Coast South operator where intercity-type services are largely confined to the routes between London and Chester, Liverpool, and Manchester. Service group separation at Northampton also provides a more rational division between Euston corridor and West Midlands local services, the former incorporated into a single West Coast South operating unit at London Euston.

The third option shown on the right assumes incorporation of Birmingham-Manchester services which could generate decarbonisation and fleet benefits. This would however, require a determination on separating long-distance (currently CrossCountry) service groups in the West Midlands and should be considered in further strategic analysis which determines how best to serve national long-distance markets via the conventional network.

Further work will be required to understand how any proposals to alter the operator map could work following production of the Williams-Shapps Plan for Rail and the stand up of Great British Railways (GBR) as a single strategic industry body. The findings of West Coast South Strategic Advice suggest that the train service opportunities presented by released capacity and the priority options for enhancement identified permit a more centralised operating structure on West Coast South Route which may offer significant long-term operational advantages.

The capacity released by HS2 creates the opportunity for a more efficient and simpler operating structure on West Coast South Route.

The findings of the scenario testing undertaken in this work suggest that an operator map which incorporates the following is possible:

- a. Separation of local service groups London-Northampton and Birmingham-Northampton into different operators or business units,
- b. Creation of a West Coast South Route operator or business unit focused on the residual, non-HS2 intermediate markets and service groups,
- c. Provision of a single operator at London Euston (excluding Caledonian Sleeper, London Overground and Open Access operators).

These recommendations should inform wider discussion on the future of the national operating map following the Williams-Shapps review and as control over contracting is taken up by Great British Railways.



Rolling Stock Requirements

WCCSA does not make any specific recommendations on what rolling stock should operate or be procured on the West Coast South network. However, some general recommendations are made which should guide changes to fleet in the long term.

Most immediately, it is important to maximise operational flexibility by rationalising the West Coast South fleet around fewer rolling stock types. This must, however, be balanced against the need to serve a variety of intercity, interregional, and local markets into the future. It is recommended rolling stock procurement builds toward provision of a basic two-type fleet where units in each type are interchangeable:

Intercity	Rolling stock which operates limited-stop, intercity services where seated capacity on longer formations is a focus.
Interregional	Rolling stock which operates more frequently calling, shorter distance services where on-train capacity can include a more even balance between seated and standing.
Local	

Provision of a two-type fleet will reduce the complexity of operations and support the flexibility to interwork services, as well as step-up units in times of perturbation. It is recognised that this will not be achievable immediately; instead this recommendation should be considered an end state and should feed into decisions on future rolling stock procurement made at the national level.

Achieving the two-type fleet would also require implementation of single traction type for both, namely an entirely Electric Multiple Unit (EMU) fleet, given the current differences in rolling stock performance across different traction types. This will not be achievable without addressing the following issues which are not in scope for WCSSA:

London-Chester Services	Hourly services between London Euston and Chester will be operated by bi-mode units ahead of HS2. These services have been retained in all scenario train plans. Transition to pure EMU fleet will require either electrification Crewe-Chester or, paring back to Crewe.
London-Shrewsbury Services	Peak services between London and Shrewsbury will operate using bi-mode units ahead of HS2. These services have been assumed to be hourly in all WCSSA scenario train plans, meaning additional bi-mode units may be required, or electrification of the route to Shrewsbury.
Birmingham-Manchester Services	Currently 2tph from Bristol/Bournemouth operate under diesel traction on the electrified route between Birmingham and Manchester. Transition to a fully EMU fleet could be achieved by separating service groups at Birmingham or by transitioning the cross-country fleet to bi-mode units for the long-term.
Services operating via East West Rail	Achieving a fully EMU fleet on West Coast South and maximising the decarbonisation benefit would require electrification of all elements of the new East West Rail infrastructure between Oxford, Aylesbury and Cambridge, if fuller long-term integration between the two routes is a priority.

Resolution of the issues outlined above would maximise the decarbonisation and operational benefits associated with rationalising the West Coast fleet. There is likely to be some benefit associated with resolution of each issue individually toward entirely electric traction in the long-term. It is not however in scope for this work to determine the operation of service groups via the West Midlands or to develop electrification schemes to Shrewsbury, Chester or on East West Rail. Likewise, the benefits of fleet rationalisation should be used to support the case for electrification, per the recommendations of Network Rail’s Traction Decarbonisation Network Strategy (TDNS) and emerging regional decarbonisation plans.

The decarbonisation benefits of separating long-distance, cross-country service groups through the West Midlands should be considered as part of ongoing work where those service groups are fully in scope.

Over the long-term it is recommended that a two-type fleet (intercity and interregional/local) should be provided for West Coast South passenger services out of London Euston.

The operational benefits of fleet rationalisation on West Coast South route should be used to support further development of required electrification schemes to Shrewsbury and Chester.

Further work should be undertaken to make sure that all passenger rolling stock operating between Birmingham and Manchester can operate under electric traction, either through changes to service group routings, or through roll out of bi-mode rolling stock over the long-term.

It is also recommended that the entire East West Rail route between Oxford, Aylesbury and Cambridge should be electrified, in line with Network Rail's Traction Decarbonisation Network Strategy (TDNS).

Finally, the transition to a single intercity-type rolling stock on West Coast South will require a single prevailing speed profile. This will not be the case in the pre-HS2 network baseline where intercity West Coast services will be operated by a mixture of tilting 125mph-limited Class 390s and non-tilt 110mph (or MU differential) limited Class 807 and 805s.

Post-HS2, the longest-distance interurban markets between London, Birmingham, Manchester, Liverpool and Scotland – where headline journey time is at a premium – will be radically improved by direct HS2 services. On the conventional network, reductions in headline journey times between some origin/destination pairs can be mitigated by increases in generalised journey times through improved service frequencies. Both developments significantly reduce the need to continue operation of tilting trains which were introduced on the West Coast Main Line to support the fastest long-distance journey times. Consequently, it should be assumed that in the post-HS2 long-term tilting trains and the Enhanced Permissible Speed (EPS) profile they operate under are eliminated from the network, and a single, non-tilting intercity rolling stock type can be procured.

The introduction of the new intercity Class 807 and 805 rolling stock on to West Coast Main Line from 2023 requires the implementation of a new Multiple Unit speed differential which will raise the linespeed restriction for those and some other rolling stock types. This is being undertaken without major infrastructure works and instead revises linespeed restrictions

based on the track tolerances and the known performance characteristics of the incoming rolling stock. It is recommended that in the long-term, this speed profile, or a revised Permissible Speed, is made applicable to all rolling stock types supporting the transition to an entirely non-tilt fleet and maximising the potential to recover any losses in headline journey times for non-HS2 intercity markets.

Long-term fleet rationalisation requires transition to a non-tilt, non-Enhanced Permissible Speed railway. West Coast South route should consequently, operate on a uniform single linespeed profile for passenger services following entry into service of HS2.

It is recommended that further work be undertaken to ensure that the planned change in MU differential can apply to all future passenger rolling stock, or that Permissible Speed is raised, on the grounds of maximising the capability of the network whilst limiting the potential for variation in speeds between passenger services.

Stations

West Coast South Stations Capacity Assessment

A detailed assessment of stations requirements has not been provided as part of the WCSSA work. This is primarily due to the uncertainty around the specific structure of the post-HS2 timetable and the limited ability to model associated impacts at stations. Network Rail will continue to assess stations capacity and safety on a case-by-case basis for West Coast South route, developing stations enhancement per the established business case process.

However, a high-level desktop stations capacity assessment has been undertaken as part of this work. This assessed the ability of West Coast Main Line South stations to handle passenger demand today and in future years focused on three key elements; platforms, vertical circulation and gateline capacity. Using the FRUIN Levels of services outlined in Figure 62, a Red Amber Green rating has been provided, indicating how each station performs currently and is likely to in future.

The stations capacity assessment tested each station within the WCSSA scope geography (except for London Euston, Watford Junction, Milton Keynes Central and Stoke-on-Trent which have been captured separately), identifying basic stations capacity impacts in three demand scenarios:

- Baseline demand, showing how each station performed pre-COVID,
- A ‘worst case’ where the heaviest possible loading was assumed,
- A ‘future uplift’ scenario which applied a uniform 35% increase in passenger loadings at each station as a proxy for demand circa 2040.

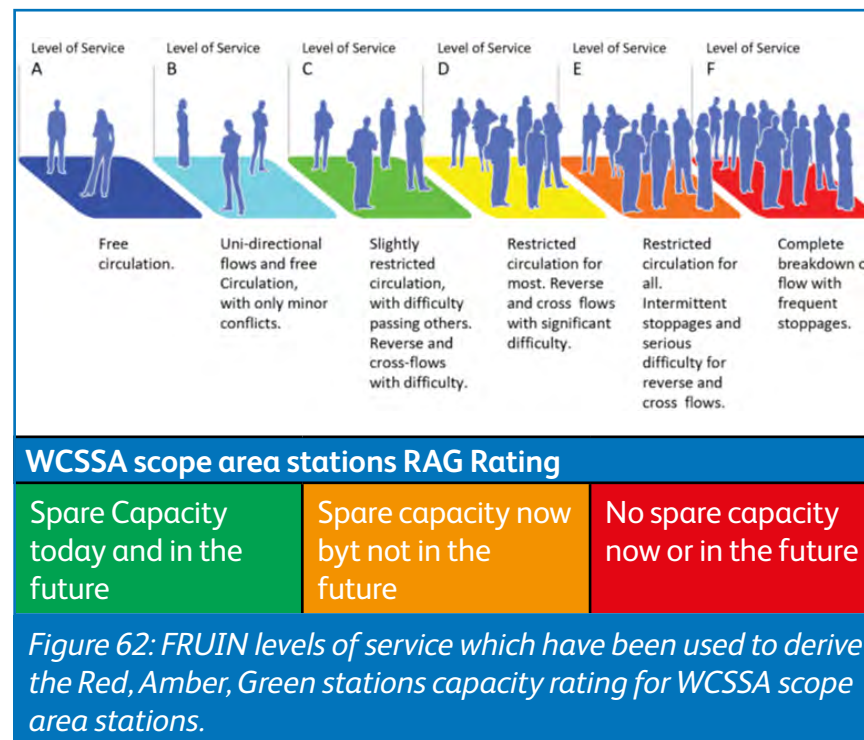



A station has been assigned a green rating if it does not exhibit capacity issues today, or in the 'future uplift' scenario. A station is given an amber rating if it does not exhibit capacity issues today but does in the 'future uplift' scenario. A red rating is given to stations where capacity issues are observed both today and in the 'future uplift' scenario.

Stations which exhibit amber or red ratings should be considered priorities for future development work following WCSSA. These are stations where there is a high likelihood that existing stations capacity issues will be exacerbated following the introduction of released capacity train services on the conventional network, though exact impacts and requirements cannot be known until the post-HS2 timetable is determined.

Watford Junction and Milton Keynes represent the next tier of larger stations on the route, with active stations capacity development programmes in flight. There are also in-development schemes at Stoke-on-Trent ahead of HS2 services calling there which merit more specific discussion. These stations have been considered separately in Table 49.

Table 49: WCSSA high-level stations capacity assessment

Station	2018/19 Entries & Exits	DfT Category	Platform Space	Vertical Circulation	Gateline
Wembley Central	3,350,506	C2	Spare Capacity	Constrained in Future	Constrained in Future
Harrow & Wealdstone	3,713,016	C1	Spare Capacity	Constrained Now	Spare Capacity
Bushey	1,520,068	E	Spare Capacity	Constrained in Future	No Gateline
Kings Langley	724,994	E	Spare Capacity	Spare Capacity	No Gateline
Apsley	667,192	E	Spare Capacity	Spare Capacity	No Gateline
Hemel Hempstead	2,008,894	C2	Spare Capacity	Constrained in Future	Constrained in Future
Berkhamsted	1,778,774	C2	Spare Capacity	Constrained Now	No Gateline
Tring	876,526	C2	Spare Capacity	Spare Capacity	No Gateline
Cheddington	84,132	E	Spare Capacity	Spare Capacity	No Gateline
Leighton Buzzard	1,841,772	C2	Spare Capacity	Constrained in Future	No Gateline
Bletchley	1,135,190	C2	Spare Capacity	Spare Capacity	Spare Capacity
Wolverton	470,352	E	Spare Capacity	Spare Capacity	No Gateline
Northampton	3,331,206	C1	Spare Capacity	Constrained Now	Constrained in Future
Long Buckby	393,560	E	Spare Capacity	Spare Capacity	Spare Capacity
Rugby	2,695,802	C1	Spare Capacity	Constrained in Future	Spare Capacity
Nuneaton	1,364,294	C1	Spare Capacity	Spare Capacity	Spare Capacity
Atherstone	171,606	F2	Spare Capacity	Spare Capacity	No Gateline
Tamworth	1,279,204	C2	Spare Capacity	Spare Capacity	No Gateline
Lichfield	1,093,746	E	Spare Capacity	Constrained in Future	No Gateline
Rugeley	183,008	F1	Spare Capacity	Spare Capacity	No Gateline
Stafford	2,466,462	C1	Spare Capacity	Spare Capacity	Spare Capacity
Stone	166,728	F2	Spare Capacity	Spare Capacity	No Gateline
Longport	55,592	F2	Spare Capacity	Spare Capacity	No Gateline
Congleton	314,312	E	Spare Capacity	Spare Capacity	No Gateline

Table 50: WCSSA specific stations capacity issues at Milton Keynes Central, Watford Junction and Stoke-on-Trent

Milton Keynes Central	Pre-Covid Entries and Exits	7.038.736	DfT Category B
-----------------------	-----------------------------	-----------	----------------

Milton Keynes Central is a 7-platform station serving both slow and fast lines on West Coast South. The station suffers significant stations capacity issues at present, with high incidence of platform crowding in the AM peak as passengers use intercity and commuter services to get to London. High alighting loads from commuting passengers generate long platform clearance times in the evening peak resulting from the single staircase available for passengers to exit. Congestion issues will be transferred to the gate line if more vertical circulation capacity is provided.

A congestion relief project is investigating ways to relieve platform clearance times currently exceed 4 minutes. The project is assessing the impact of increased vertical circulation capacity on platform clearance times (specifically on platforms 5 and 6), reducing the risk posed to passengers by fast passes of non-stop intercity trains.

The results of the train service testing undertaken in WCSSA demonstrate the extent to which Milton Keynes Central could become a hub with a significantly increased quantum of calls compared to today, on both the trunk West Coast South route and potentially via East West Rail. The case for the in-development capacity scheme is in no way undermined by these findings, as the risks identified on platforms 5 and 6 will persist for the next decade. However, long-term requirements may include widening the existing footbridge and improved staircase/elevator access to all platforms, as well as widening the gateline and significant concourse redevelopment. Additional platforms at Milton Keynes Central have been identified as a priority for further work following the scenario testing. It is recommended that this work incorporates the need to fully address long-term stations capacity in line with the Milton Keynes ‘hub’ concept outlined in Planning Principle F should it be progressed further.

Table 50: WCSSA specific stations capacity issues at Milton Keynes Central, Watford Junction and Stoke-on-Trent

Watford Junction	Pre-Covid Entries and Exits	8,460,154	DfT Category B
<p>Watford Junction currently provides access to, and interchange between, local London Overground and St Albans Abbey Line services, and inter-regional and long-distance, intercity services on the West Coast Main Line. Several areas in the station experience significant passenger congestion during peak periods currently. The limited capacity in the existing station subway and on staircases to and from platforms generates dangerous levels of crowding following the arrival of trains on Platforms 7 and 8. This congestion frequently coincides with fast passes on the main lines, putting passenger safety at risk. There is also insufficient capacity at the gatelines which are regularly opened to mitigate associated congestion, delay and safety risk. These issues have persisted even in periods of reduced footfall following the COVID pandemic.</p> <p>A station improvement scheme is being developed to provide new circulation routes around the station and to/from a new concourse and entrance, with the aim of reducing congestion and improving the station experience for all passengers. A key finding of the work undertaken in WCSSA is the potential for released capacity to be utilised for a greater quantum of service, particularly for intercity and interregional type services, at Watford Junction. This could generate additional demand at the station, exacerbating current issues and underlining the case for investment in a new stations footbridge to facilitate increased cross-platform movements. The long-term solution could be impacted by any wider investment related to the St Albans Abbey line and the currently disused Croxley branch. These issues will be picked up separately in a Watford Area piece of strategic advice.</p>			
Stoke-on-Trent	Pre-Covid Entries and Exits	3,235,960	DfT Category C1
<p>Stoke-on-Trent station is the main station in the North Staffordshire conurbation. It is served currently with long-distance intercity services direct to London, as well as interregional services to the West Midlands and Manchester, and local services between Derby and Crewe. The station has three platforms, including a short north-facing bay platform which is used for local services to Manchester. There are currently several local developments around the station area, including a residential and commercial development site on the site of the old goods yard as well as closure of existing east-side car parks and construction of new car park on the west side of the station.</p> <p>Current stations capacity issues relate to the width of the west side gate line and the constrained space which can quickly fill in peak times with passengers backing down into the subway. Vertical circulation is also a significant issue at Stoke-on-Trent given primary access is through the narrow subway, and the relative difficulty in accessing the small lifts in the station. HS2 services are planned to call at Stoke-on-Trent. Stations capacity issues must be tackled directly as part of any HS2-linked investment or increases in local service provision. Options to facilitate the latter will be considered separately as part of a Stoke Area piece of strategic advice which will explore the potential for uplifted local services.</p>			

The high-level assessment shown in Table 49 and Table 50 indicates that most stations on West Coast South route do not exhibit major stations capacity issues even in a long-term growth scenario. This does not mean that stations capacity issues will not occur in future. These should be managed on a case-by-case basis regardless of the high-level results provided here.

The assessment did demonstrate however that some stations are at risk of developing stations capacity issues in future. Vertical circulation was identified as an issue at Bushey, Leighton Buzzard, Rugby and Lichfield Trent Valley, as well as both vertical circulation and gate line capacity at Wembley Central and Hemel Hempstead. All these stations, depending on the train service scenario assumed, could receive significantly uplifted quanta of passenger service following released capacity. This may exacerbate problems driven by a uniform increase in stations demand especially where the long-term potential for interchange is a key driver in providing an enhanced passenger service; notably at Rugby, Tamworth and Lichfield Trent Valley. It is recommended that long-term stations capacity assessment is focused on these stations as more detail as the post-HS2 timetable is developed in the coming years.

More immediately, Harrow and Wealdstone, Berkhamsted and Northampton stations exhibited issues with vertical circulation in all demand scenarios. This risk is particularly acute at Northampton where an improved quantum of service was identified as a key priority for the released capacity train service. Likewise, there is also significant scope to use released capacity for additional calls at Harrow and Wealdstone and Berkhamsted

primarily for local services. This could present acute problems in peak hours, given the nature of these markets and commuting into London. Stations capacity assessment should also be undertaken at these stations, given the potential for long-term changes in the passenger service structure consequent on introduction of HS2.

Reopening Fast Line Platforms

In the Intermediate Markets and East West Connectivity scenarios it was found that the objectives set could be best achieved by calling some intercity type services on the fast lines, notably at Leighton Buzzard and Hemel Hempstead, as key growth markets on the 'Euston Corridor'. This does not routinely occur today as the fast line platforms are generally closed on safety grounds, minimising the risk posed to by passengers by fast passing intercity trains. In general, the fast lines are only utilised during times of perturbation or degraded working, or when a two-track regime needs to operate with a closure of the slow lines.

Opening the fast lines to regular passenger trains may serve a specific operational or economic purpose, utilising the capacity released by HS2 or the enhancements identified in this work to better support key rail markets. However, it may also import a safety risk by exposing passengers to more non-stop trains and generating an according impact on suicide prevention and safety. Further, utilising formerly closed platforms could exacerbate issues related to vertical circulation identified above by increasing the flow of passengers between platforms, and

through more sets of stairs and elevators. These specific issues related to stations capacity impacts and safety risks must be considered in further development work as the post-HS2 timetable is developed. There is a strong likelihood that utilising fast line platforms routinely at some stations where they are not routinely used today will be required. This can only occur if the appropriate stations capacity, vertical circulation and safety mitigations already exists ahead of any timetable introduction with the required calls.

London Euston

London Euston conventional station has experienced significant passenger capacity issues historically, and remains an at-capacity station from a pedestrian flow perspective. WCSSA does not present any further options or recommendations on addressing these issues as it is expected they will be comprehensively resolved as part of the planned Redevelopment of Euston Conventional Station (RECS) project. The results of the concept train planning analysis, and in particular, those of the Peak Commuter test in scenario five will now be used by the RECS programme as a basis to assess:

- Potential stations capacity impacts in a maximum released capacity scenario train service,
- Possible train service trade-offs associated with platform closures required as part of the construction phase (planned to occur post-HS2 Configuration State G).

Network Rail will continue to work with the industry to determine an industry-acceptable programme to redevelop the conventional station – subject to the established business case process – which minimises any detrimental impacts on utilisation of the capacity released by HS2.

New Stations

The capacity released by HS2, as well as any additional capability provided through conventional network enhancement, can be used to serve new stations on West Coast South route. This does, however, force a trade-off against passenger or freight services by using finite capacity for additional station calls.

This study adopted an approach to new stations proposals in which a set of four ‘Group A’ baseline new stations proposals – considered to be relatively well developed or less operationally challenging to accommodate - were included in every train plan. Alongside these, a set of four additional ‘Group B’ new stations proposals were included in the New Connections scenario. These were determined by the relative maturity and increased operational challenge posed compared to the baseline new stations.

This approach to testing gave a whole-system view on the capacity impact of the new stations proposals when assumed in a train plan together. It did not provide specific appraisal of new stations proposals. It remains Network Rail’s position that individual proposals for new stations should be developed on a case-by-case basis in consultation with Network Rail directly.

However, new stations proposals on West Coast South route should be pursued in line with the analysis and recommendations of this report noting some key findings in relation to each.

Group A: New Stations Included in all Scenarios

There is likely to be a strong case for a new station at Coventry East on both operational and strategic grounds given:

- a. The potential for released capacity to support intercity-type calls for Coventry-London services as well as local services,
- b. The improvement in network capability should turnback facility be provided for local West Midlands services to terminate at the station.

These requirements will be picked up in more detail as part of Network Rail's Coventry Area strategic advice. It is recommended that they are included in any subsequent development work for a Coventry East new station as a minimum.

The WCSSA also found that calls in intercity-type and interregional services could be accommodated at a new station between Rugby and Long-Buckby. This did however require the capacity released by HS2 to provide an intercity-type service via Northampton. This would support the strategic case for a Rugby Parkway proposal but affirms that this scheme is effectively reliant on released capacity to generate the greatest benefit and achieve strategic needs in full.

Both new stations proposals for Polesworth and Stoke South could be accommodated with minimum difficulty in all train plans. This was due to the provision of suitable interregional type services in all scenarios, and the relatively low capacity impact imported by assuming station calls. Further work will be required to build a case for both proposals factoring in the potential for HS2 released capacity as a basis for long-term strategic fit. It is likely the pre-HS2 timetable constraints make both schemes undeliverable ahead of that point.

Group B: New Stations Included in the New Connections Scenario Only

The results of the New Connections scenario demonstrated the capacity constraints imposed by assuming a wider range of new stations in more challenging locations. Of these new stations, Brinsford was found to be the least impactful, with stations calls accommodated in an interregional type-service. More detailed work is required to understand the strategic need for this proposal as well as target markets. The trains calling here were also assumed to call at a Stoke South station and there is a risk that together these services offer a detrimentally reduced headline journey time to Birmingham, Stoke-on-Trent and Crewe.

The new station proposal at Meecebrook was difficult to serve appropriately in all train plans. This was because of the assumed interregional and local service structure operating north of Norton Bridge junction in all scenario ITSSs. There will be limited opportunity to provide an adequate local service to Birmingham even post-HS2 which, given the engineering

complexity of introducing a new station on the four-track section at Meecebrook, will not translate into a strong strategic case.

While it may be possible to call extended Chase Line services at Meecebrook for direct connectivity to Walsall, this would present a circuitous route to Birmingham and may require infrastructure intervention at Rugeley North Junction. Alternative proposals for this new station, which can satisfy the strategic need, should be explored first. Siting the new station on the Norton Bridge lines between Norton Bridge Junction and Stone may offer greater potential to call interregional-type services, on a half hourly pattern, between Birmingham and Stoke-on-Trent, creating a stronger strategic case. This is likely to be deliverable only following HS2 and could represent a significant wider impact if both Brinsford and Stoke South new stations are served by the same trains. This new station proposal should be considered a post-HS2 scheme.

The most significant capacity impact was driven by the assumed new stations at Daventry – on the fast lines between Hanslope Junction and Rugby – and at South Northampton – on the slow lines between Hanslope Junction and Northampton. A key finding from all scenario tests is the extent to which this point on the network remains significantly constrained even following the release of capacity by HS2. A new station on the slow lines south of Northampton severely impacted the ability to time passenger and freight trains. The result was a significantly reduced opportunity to plan intercity type services, and a consequent need for additional infrastructure on the wider network to unlock

the required capacity.

It is recommended that a more detailed and holistic study assessing the local and strategic rail needs for new stations in the Daventry / Northampton area is undertaken. Network Rail will work with partner organisations to provide a credible assessment and advise on the long-term strategic fit of any resulting proposals based on likely impacts to the wider network.

The testing undertaken in WCSSA found that the proposed new stations at Rugby Parkway, Coventry East, Polesworth and Stoke South could be served appropriately in future utilising the capacity released by HS2.

Maximising the operational and strategic benefit of the Coventry East proposal would require turnback facility for local services from Birmingham, as well as sufficient platform length to call intercity rolling stock. This should be explored as a basis for further development.

New stations at Daventry, South Northampton and Meecebrook imported a much greater impact on network capability and drove significant trade-offs in passenger and freight service. It is unlikely that the current proposal for a Meecebrook station on the four-track mainline north of Norton Bridge Junction can be provided with an appropriate level of local or interregional service. Alternative options for this proposal should be explored.

It is recommended that further development work on any new stations between Milton Keynes and Rugby is not undertaken until a holistic assessment of local rail stations needs has been completed. This must weigh the strategic case for new stations against the significant impact on wider network capability identified. Network Rail will advise partner organisations in this work, based on the findings outlined in this report.

Freight Traction and Gauge Clearance

The capacity released by HS2 can be used to support growth in demand for rail freight over the long-term. In all scenarios tested in this work it was found that a quantum of freight service which is higher than today's could be accommodated, assuming longer and heavier (775m and 1800t) loads. There is however, a distinct trade-off associated when planning for the highest levels of freight growth, most notably on the slow lines between London and Northampton where rail capacity is likely to remain very constrained.

The most efficient way to plan for high-growth levels of freight is to utilise released capacity to support new national routing options, namely via East West Rail infrastructure and the F2MN route to Nuneaton, which are alternative to London's orbital lines.

West Coast South Strategic Advice has demonstrated that main line capacity for growth in freight is available over the long-term. It has not made a determination on which end-to-end paths should be provided, or where additional freight terminals should be situated. This is for the industry to determine in response to developing market conditions and wider economic needs. It is clear however, that utilisation of new strategic routes for freight create the potential for new freight sites which could be served full post-HS2. This could include new sites on situated on the East West Rail route, or even potentially via the Weedon fast lines should appropriate looping capability for Class 4 freight be provided.

The potential for uplifted capacity and routing options for freight, and opportunity associated with new terminal sites, does however generate some key issues and dependencies which will require further work to clarify.

Electric Traction Sectional Running Times

The WCSSA capacity assessment assumed that over the long-term, Class 4 freight via West Coast South route will operate under electric traction. This would provide the ability to use powerful electric locomotives which perform better under heavy loads than equivalent diesel rolling stock. This is considered a safe assumption given:

- The government's stated commitment to achieve net-zero emissions by 2050 and decarbonise the transport network,
- Network Rail's Traction Decarbonisation Network Strategy (TDNS) which aims to remove diesel rolling stock from the network,
- The direction of travel within the freight sector to procure electric, bi-mode and tri-mode locomotives to replace diesel traction in future.

The performance of electric rolling stock for freight assumed in the WCSSA work demonstrated the extent to which electric traction could generate important benefits for utilising long-term capacity through reduced sectional running times on constrained parts of the network. Specifically, under electric

traction it was possible to plan freight via the fast lines between Hanslope Junction and Rugby.

Consequently, there are significant capacity benefits related to traction decarbonisation which are realisable in future. Failure to implement the TDNS or procure electric traction for freight will undermine the findings of this report and risk the ability to achieve long-term growth in freight by rail.

Further, this work has assumed today's speed profiles for freight which limit Class 4 freight to 75mph and Class 6 to 60mph. Raising this speed profile, in combination with better performing rolling stock, could have a significant impact on available capacity, especially if the differential between Class 4 and Class 6 freight could be reduced. This would require further work to establish technical feasibility as well as a re-planned capacity assessment to determine the extent of the benefit.

Freight Gauge Clearance

HS2 presents an opportunity to provide greater capacity for freight on the trunk West Coast South route, as well as create an opportunity to use additional routes for freight via F2MN and East West Rail. As noted in Planning Principle A previously, West Coast Main Line South is at present a critical route for intermodal freight traffic specifically; that is to say, domestic, short-sea and Channel Tunnel container traffic. The growth in demand for rail freight on the route will be driven largely by growth in these sectors too.

West Coast South route is cleared to loading gauge W10; this effectively limits the types of containers which can operate on the route including movements of wide body 'swap boxes' which provide for a significant volume of short-sea ports traffic. The potential for intermodal freight growth – and utilising the capacity made available on the conventional network by HS2 – will be limited if loading gauge restrictions mean that some larger types of container cannot be moved via West Coast South and must be routed elsewhere. This could likewise limit routing options to support rail freight markets, notably between ports and logistics sites in the West Midlands and Northamptonshire area.

It is recommended that further work is undertaken on incremental gauge clearance to W12 standard for West Coast South. Gauge clearance works should focus on the route section north of Bletchley as a priority given the potential to use the East West Rail infrastructure (which will be cleared to W12 on inception) as a long-term strategic route for freight, and more effectively utilise capacity on West Coast South by avoiding the constraints imposed on the slow lines between London and Milton Keynes.

Longer, Heavier Freight

For the purposes of capacity planning in WCSSA, freight timing loads have been used which would provide for 775m and 1800t Class 4 trains. This is in line with the industry direction of travel for longer and heavier freight trains as standard, ensuring efficient use of rail capacity by maximising the amount of goods each service can transport.

Given that the capacity assessment undertaken in this work has been based on a standard hour and nominal freight path routes, no specific recommendations have been made for existing or planned strategic rail freight sites, or the infrastructure requirements for sidings and freight loops.

It is a general recommendation of this strategic advice that any new freight loops or freight sidings provide for 775m long freight trains as a minimum, and that existing sites which do not meet those requirements are lengthened on a case-by-case basis. There will be a greater imperative to achieve this in future given this strategic advice demonstrates the extent to which an uplift in freight traffic can be achieved on West Coast South route following introduction of HS2.

National Freight Routing

The freight focus ITSS tested in this work set an ambitious hourly provision for freight. The testing found that this full specification – including all required Class 4 and Class 6 freight via London and East West Rail – could not be accommodated without one of the following:

- a. Significant infrastructure intervention,
- b. Breaking the minimum requirements for passenger service set in the planning principles for this work,
- c. Segregation of freight classes into different hours of operation.

More efficient use of network capacity could be achieved by more formally segregating operation of different types of freight traffic by time of day or route. This will require further assessment of long-term market conditions as they evolve, weighing the potential for network capability and efficiency against the suitability of routing options for freight which have not been included in the scope of this study.

It is recommended that – in light of the findings of this work – a wider freight routing strategy is undertaken which considers how to utilise the capacity released by HS2 for freight holistically alongside other key freight corridors including, for example, the West Midlands and Midland Main Line.

WCSSA makes some general recommendations on future freight capability and operations aimed at maximising the potential for long-term growth in rail freight via West Coast South Route:

- a. Electric traction for freight is required over the long-term on both decarbonisation and capacity grounds,
- b. Further work is required to develop an incremental improvement in freight gauge to W12 to support growth in domestic, short-sea and Channel Tunnel container traffic, cognizant of the potential for F2MN/EWR to provide new, gauge-cleared routes,
- c. All new freight loops, sidings and SRFIs on West Coast South should be developed to provide capability for 775m long trains from the outset,
- d. A national freight routing strategy should be undertaken to consider how network capacity (including that released by HS2) could be most effectively used for freight, potentially through segregation by class or route.

Decarbonisation and Power Supply

The assessment and recommendations outlined in this document have been produced in line with the government's policy on transport decarbonisation and the target to achieve net-zero carbon emissions by 2050. West Coast South route is an electrified railway and therefore presents a significant opportunity to support decarbonisation targets through modal shift to rail. All scenario tests undertaken in this work demonstrate the extent to which mode-shift as an objective could be targeted for both passenger and freight train service options.

At present, some services operating on West Coast South route do not operate under electric traction. These include:

- Passenger services between London and Chester,
- Peak passenger services between London and Shrewsbury,
- Passenger services from the Southwest to Manchester which run via Birmingham and Stoke-on-Trent,
- Most freight services which operate under diesel traction.

New bi-mode passenger rolling stock is planned to be introduced to phase out diesel operations between London and Chester / Shrewsbury by the mid-2020s. As a consequence, Network Rail has been evaluating these train service changes to understand the impact on existing power supply arrangements, and as part

of a longer-term strategy to upgrade supply points and provide for Auto-Transformer feeding throughout the route. This work is being undertaken separately to WCSSA and on a regional basis. Importantly however, the WCSSA study does make some key recommendations which will have an impact on long-term power supply arrangements and the need to make investments in the power supply system over the long-term. This includes the imperative for fleet rationalisation and the target of providing for a two-type fleet at London Euston. This may not be achievable until electrification of some route sections out of scope for this study – namely Wolverhampton-Shrewsbury and Crewe-Chester.

Changes to the CrossCountry network have not been tested directly in this work as the long-distance service structure via the West Midlands will be considered as part of separate strategic advice. However, over the long-term, power supply arrangements should factor in the need to operate all passenger services between Birmingham and Manchester under electric traction. This may be achieved by either:

- Procurement of a bi-mode fleet for services operating from the Southwest to Manchester via Birmingham, electrification or a combination of both,
- Long-term service group changes at Birmingham and operation of EMUs for intercity-type traffic Birmingham-Manchester,



Most importantly, the assessment undertaken in WCSSA found that electric traction for freight is a key aim not only on decarbonisation grounds (in line with the government's Transport Decarbonisation Plan and Network Rail's Traction Decarbonisation Network Strategy) but also on capacity and capability grounds, where the improved performance of electric locomotives translates into a beneficial impact on wider network capability.

Given the much greater power draw that heavy freight services impose on the power supply system, it will not be possible to accommodate substantially increased electric traction for freight in the long-term without further investment in the traction power system. It is strongly recommended that the development work required to provide the power supply capability for a high-growth level of freight (as identified in the WCSSA scenario testing) is undertaken.

While the concept train plans produced as part of this work are not detailed enough to act as an accurate basis for power modelling, it is recommended that the train service structures identified can inform the basic quantum of long-term freight services as the structure of the post-HS2 timetable becomes clearer in the coming years. Failure to upgrade the power supply system for the long-term will risk the ability to fully decarbonise the transport network as well as fully take advantage of the capacity released by flagship investments like HS2 and East West Rail.

Climate Resilience

The UK government's policy for the transport network is based around decarbonisation and achieving the net-zero carbon emissions target for 2050. This is driven by a global imperative to reduce greenhouse gas emissions which have contributed to rapidly rising global average temperatures. Climate change is recognised as a long-term existential threat around the world and this strategic advice is aligned to the government's policy in tackling it.

Climate change is a present threat with significant rises in global average temperatures observed around the world in recent decades. The changes in climate driven by rising global temperatures continue to generate immediate impacts for the railway network which must be factored into any infrastructure strategy.

It is imperative that transport infrastructure retains resilience against changing weather patterns which will consist of more frequent extreme events, and greater extremes in seasonal conditions. These impacts can be broken down through a set of key weather types, all of which are likely to see an increased frequency and severity of extreme events which will impact on the ability of the railway to function safely. They are summarised in Table 51.

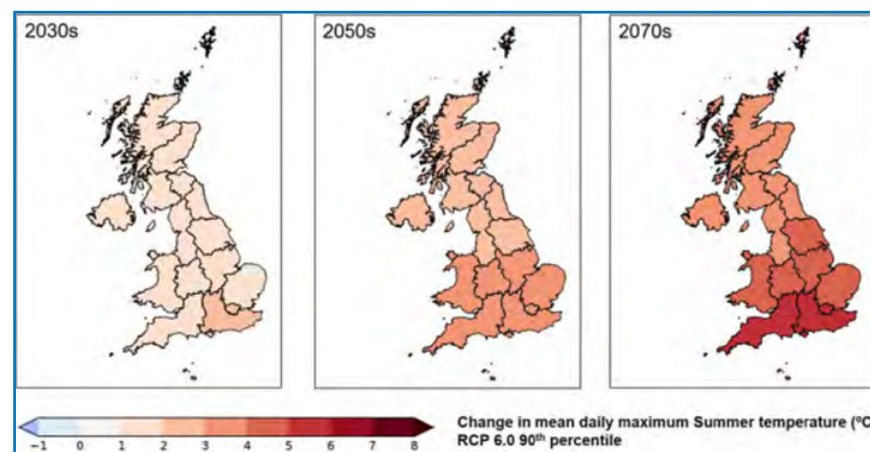

Figure 63: UK Climate Projections (2018) modelled future change in mean daily maximum summer temperature (centigrade) from a 1981-2000 baseline.

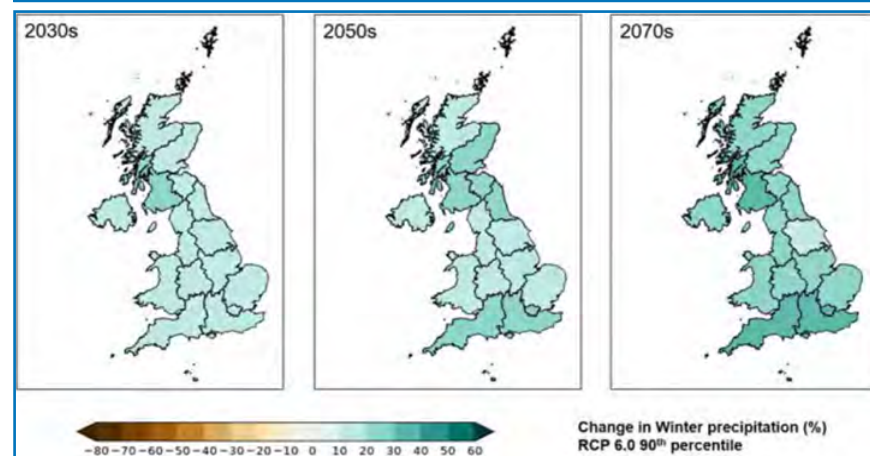

Figure 64: UK Climate Projections (2018) modelled future change in winter precipitation (percent) from a 1981-2000 baseline.

Table 51: Weather types and associated railway impacts.

Weather Type	Network Impact
Rain	<p>By the 2050s, it is expected that there will be much greater seasonal variation in rainfall across Britain, increasing by 40% in December and decreasing by 37% in July. Railway drainages are built to robust modern standards and can deal with moderate levels of rainfall. However, extreme rainfall can overwhelm drainage systems leading to flooded track beds, destabilise earthworks and submerged electrical supply equipment, all of which can force trains to stop running and degrade the timetable.</p> <p>In extremely hot periods rain becomes less frequent and extreme evaporation – known as desiccation – can harden and crack the ground, creating an increased risk of flash floods. This presents a particular risk to infrastructure which has not been engineered for extreme volumes of water and can accelerate the deterioration of assets which have been engineered to deal with more moderate and consistent rainfall.</p> <p>Both extremes in heavy rainfall in winter as well as dry periods in summer increase the risk to flood sites across West Coast South Route, as well as an increased risk of water inflow from third party land which must be assessed and mitigated comprehensively.</p>
Wind	<p>High winds impact railway performance by generating increased risk of objects being blown on to the railway or into overhead line equipment, including trees and vegetation, as well as accelerating erosion in coastal locations. Speed restrictions are often imposed to protect against damage to trains as well as ballast wash-out or damage to track formations.</p>
Cold	<p>Current climate change models suggest that winters will become shorter meaning frosty and snowy days will reduce. However, the combination of increased and more intense rainfall with residual periods of freezing will lead to higher risk of ice formation in tunnels and structures, as well as an increased risk to earth works, buildings, structures, and drainage from the cycle of freezing and thawing.</p> <p>Snow and ice will also remain a risk to operational railway due to the potential to obscure signals and impair the movement of mechanical switches, as well as damage overhead line equipment.</p>

Table 51: Weather types and associated railway impacts.

Weather Type	Network Impact
Fog	Fog is not currently a major problem for railway operations nationally, though it can make it difficult for train drivers to read signals and therefore generates a safety risk. Incidences are however low, and it is not anticipated that the number of foggy days will increase.
Heat	Extreme periods of heat can generate a specific set of issues for railway infrastructure including buckling of rails which expand as temperatures rise, as well as issues related to electrical equipment. Mitigation measures include painting rails white to deflect the sun's rays and reduce the increase in temperature, but more frequent periods of extreme high temperatures across Britain will lead to an increased incidence of track deformation, speed restrictions and suspension of services.
Lightning	Lightning strikes are difficult to predict, however there is an increased likelihood associated with more frequent, high-energy storms. This poses a specific set of risks where trees struck by lightning fall on to the track, as well as potential overload of electrical infrastructure.
Leaf Fall	<p>Leaves on the track cause moisture and oil to contaminate the rail head, which reduces the grip trains have. This is a serious safety risk on the railway as the contaminated rail head results in much lower adhesion between train and track, and thus significantly reduces stopping distances as well as the ability to accelerate/decelerate. This is currently one of the most significant causes of delay on the network.</p> <p>Higher temperatures combined with increases in average rainfall will elongate the growing season and therefore more profuse vegetation. When autumn arrives, strong winds are the major contributor to leaf fall, demonstrating the extent to which changes in weather are likely to exacerbate existing challenges</p>

Network Rail continues to work to address the impact climate change is having on its infrastructure. Between 2007 and 2019 adverse weather conditions created between 150k and 500k minutes of delay each year in Northwest and Central Region (shown in Figure 65). There were persistent and significant levels of delay attributable to poor adhesion (driven primarily by leaf fall), flooding and high winds, and to a lesser extent through heat, with a severe but less frequent impact observed for snowfall. This translates into a significant financial and economic impact for Network Rail – in the form of raised Schedule 4 costs to cover delays attributed to users and operators – as well as more widely in the economy through delayed and cancelled trains.

Delays are created by the imposition of speed restrictions as a response to potentially dangerous weather events. They are imposed in several forms depending on specific circumstances.

Temporary Speed Restriction (TSR)	A speed, less than permissible speed for a defined section of route, applied for a pre-planned period not normally exceeding six months.
Emergency Speed Restriction (ESR)	A speed restriction which is either not shown in the Weekly Operating Notice (WON) for drivers, or which is more restrictive than that shown in the WON.
Blanket Speed Restriction (BSR)	A speed restriction imposed over a wider area and advised via Operations Control.

In future, the roll out of European Traffic Control System (ETCS) digital signalling will remove the need for separate categories of speed restriction as information of speed limits for ETCS lines of route can be directed straight to drivers in-cab. While this may generate some efficiencies in carrying out speed restrictions in response to adverse weather conditions, the increased frequency of extreme weather events outlined above is likely to drive a net increase in delay minutes as more frequent and extreme events across each weather type are observed and the appropriate response is taken.

As climate change will continue to exacerbate known issues in the Northwest and Central Region and on West Coast South Route it is critical that appropriate mitigations and resilience are factored into the ongoing maintenance and renewal of existing network assets, and the development of any network enhancements which may follow on from this report. This is vital if the long-term performance of the rail is to be assured, and the benefits associated with the release of conventional network capacity are fully realised.

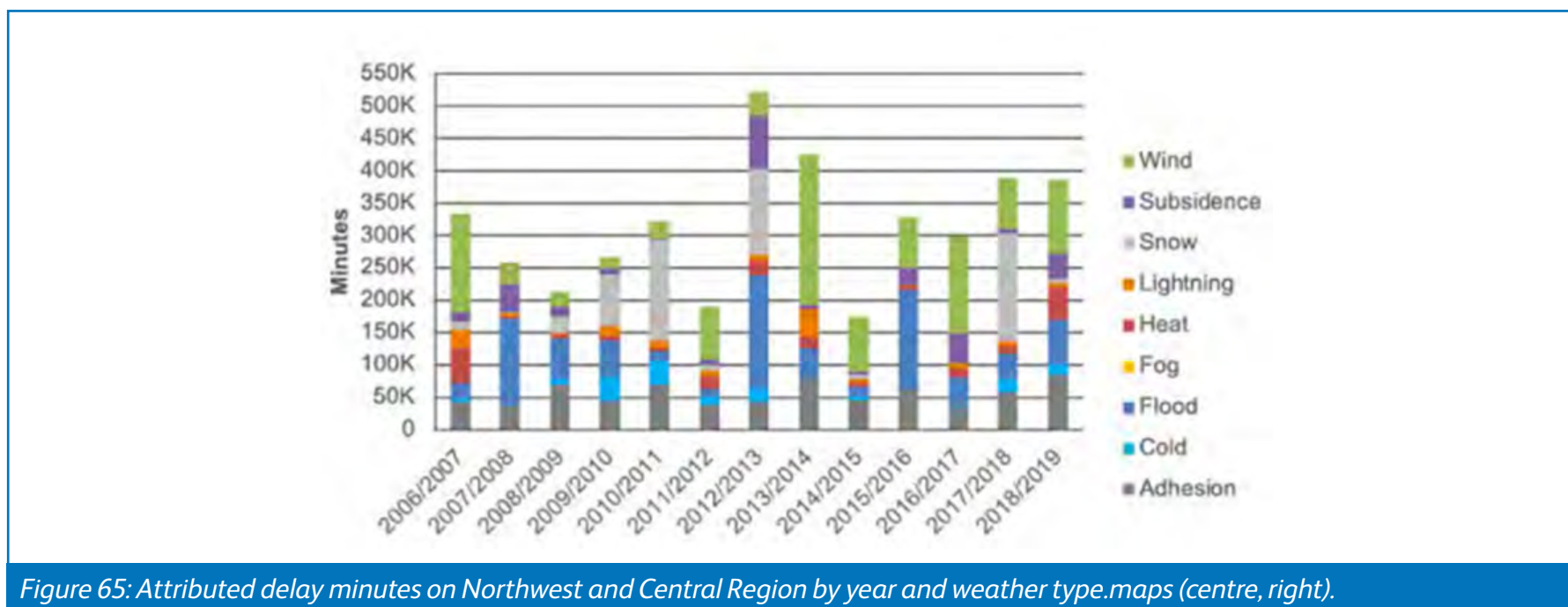

Figure 65: Attributed delay minutes on Northwest and Central Region by year and weather type.maps (centre, right).



This report reiterates the findings of Network Rail’s national Climate Adaptation workstreams and underlines the need to protect network assets as weather events become more frequent and severe due to climate change. It also recommends that further work be undertaken specific to West Coast South route which should:

- Identify the key at-risk parts of the route and the extent to which change in extremes for each weather type are likely to exacerbate those risks,
- Quantify the financial and economic impact of delays imported on to West Coast South route through weather events,
- Consider specific mitigations at key parts of the network which should be considered a priority for further funding, or could be captured as part of the priority areas for enhancement development identified in this work.

Further assessment related to weather resilience which follows on from this strategic advice has been described in the final section of this report.

Summary and Further Work



This report has described the train service options made available by the release of conventional network capacity following introduction of HS2, and has presented a series of recommendations which should inform how the associated transport benefits can be realised.

Network Rail will continue to work with the DfT, West Coast Partner Development and the wider industry to shape the post-HS2 timetable. It will use this document as a basis from which to advise partner organisations as policy and objectives for rail in this area develop.

Network Rail will also continue to advise funders on the development of long-term infrastructure enhancement based on the recommendations outlined in this report. It is anticipated that further work related to the identified infrastructure packages will be undertaken, ensuring that long-term network capability and requirements on West Coast South route can account for the strategic priorities outlined by partner organisations.

This strategic advice is a route-wide, long-term assessment. It is not possible to identify, predict or test all possible proposals to make change to the infrastructure. This is not a blocker to such proposals, but it is Network Rail's view that any such proposals made by industry partners or third parties should first consider the findings and recommendations in this report as an agreed direction of travel before engaging in the usual business case development process.

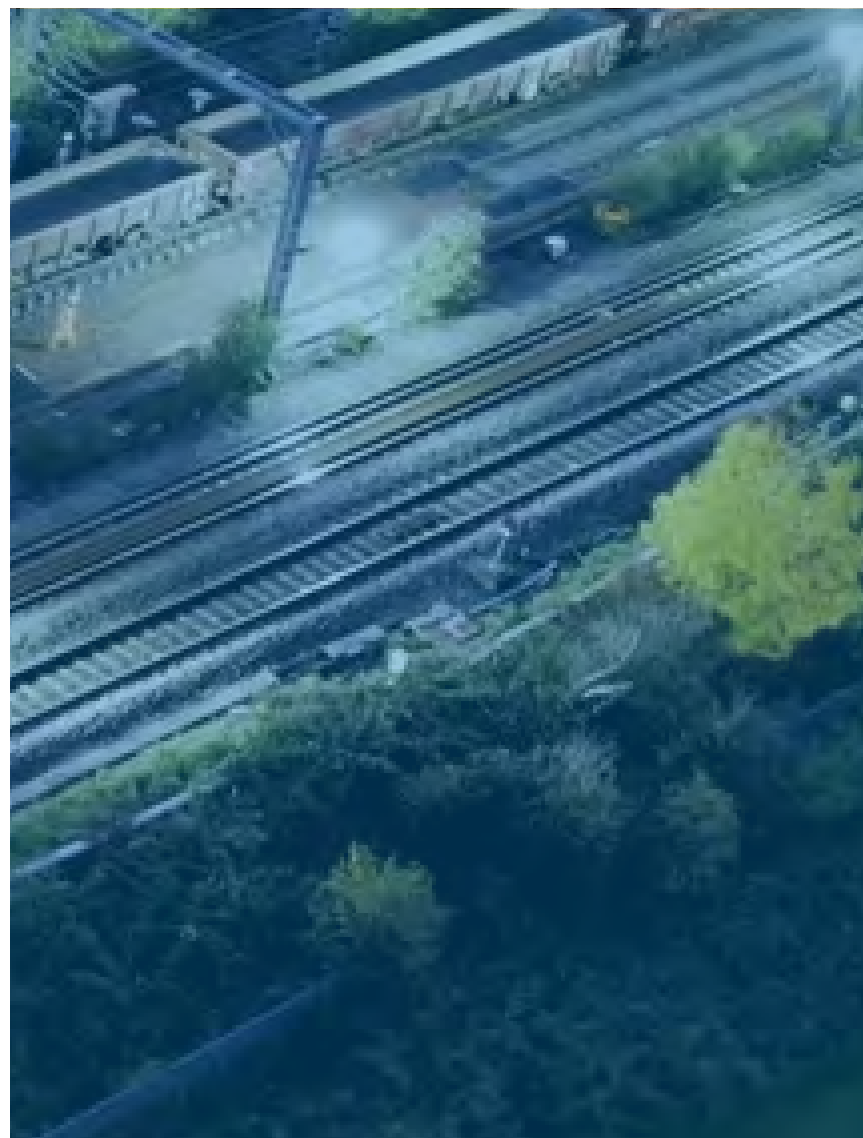

This strategic advice has identified long-term opportunities to enhance West Coast South network, and articulated what is required to realise them. The results of the analysis have however, generated more questions and so there is a need for further work to be undertaken.

The following areas of work should now be prioritised based on the findings and recommendations articulated in this report:

- a. Strategic advice focused on the **Milton Keynes Area** which evaluates the specific improvements in connectivity and freight routing derived from integrating the East West Rail and West Coast South networks,
- b. Strategic advice focused the **Stoke-on-Trent Area** which considers the impact of released capacity services as well as local service aspirations, identifying impacts and requirements on the infrastructure.
- c. A cross-regional **Freight Routing Strategy** which evaluates options to maximise the capability of the network in support of long-term growth in rail freight,
- d. A cross-regional **Long-Distance Passenger Strategy** which considers where priority intercity services should operate into the long-term and how to appropriately serve major long-distance flows in future,

- e. A **Local Stations Needs** assessment for the West Northamptonshire area which will be required to inform the development of any new stations locally noting the capacity and capability impacts identified in this report.

It is anticipated that alongside the new workstreams identified above, the outputs and recommendations made in this strategic advice will inform ongoing strategic assessment in interfacing areas, most notably Network Rail's long-term planning activity for the **Northwest and Manchester**.

Appendices



Appendix A – WCSSA Governance and Stakeholder Engagement

West Coast South Strategic Advice governance structure:

Governance Group	Role	Representation
Steering Group (RIRG)	Oversight and endorsement of the WCSSA workstream.	Industry-wide. <i>WCSSA has used the NW&C Region Investment Review Group (RIRG) as a steering group.</i>
Working Group	Review, feedback and input into the WCSSA analysis. Endorsement of the outputs, recommendations and final report.	Network Rail (<i>System Operator and regional SP functions</i>) Department for Transport England's Economic Heartland Midlands Connect West Midlands Rail Executive East West Rail Company West Coast Partner Development Freight (<i>various FOCs</i>) Avanti West Coast West Midlands Trains CrossCountry East Midlands Railway (<i>correspondence</i>) Arrival Rail London (<i>correspondence</i>)
<i>Ad Hoc</i> Consultation		Arriva Rail London Caledonian Sleeper Grand Union Trains
Technical Analysis	Testing, analysis and generation of outputs/options.	Network Rail (<i>Advanced Timetabling, Economic Analysis, Programme Development, Stations Capacity, Freight and Network, Regions</i>)

Further detail about Working Group dates, content and attendance can be provided upon request.

Appendix C - Freight Focus ITSS and Generalised Journey Times

Base ITSS

Service Type	Code	From	To	Route	Calling Pattern	Pattern	Rolling stock	Length	Class
HS2	HS01	London Euston (HS2)	Birmingham Curzon Street	HS2	Old Oak Common, Birmingham Interchange	20-Minute Pattern	HS2 CC	400m	
HS2	HS02	London Euston (HS2)	Birmingham Curzon Street	HS2	Old Oak Common, Birmingham Interchange		HS2 CC	400m	
HS2	HS03	London Euston (HS2)	Birmingham Curzon Street	HS2	Old Oak Common, Birmingham Interchange		HS2 CC	400m	
HS2	HS04	London Euston (HS2)	Manchester Piccadilly	HS2, Crewe, Wilmslow	Old Oak Common, Wilmslow, Stockport	20-Minute Pattern	HS2 CC	200m	
HS2	HS05	London Euston (HS2)	Manchester Piccadilly	HS2, Crewe, Wilmslow	Old Oak Common, Crewe, Stockport,		HS2 CC	200m	
HS2	HS06	London Euston (HS2)	Manchester Piccadilly	HS2, Crewe, Wilmslow	Old Oak Common, Stockport		HS2 CC	200m	
HS2	HS07	London Euston (HS2)	Liverpool	Runcorn WCML and HS2	Old Oak Common, Crewe, Runcorn	Half Hourly	HS2 CC	200m	
HS2	HS08a	London Euston (HS2)	Liverpool	Runcorn WCML and HS2	Old Oak Common, Crewe, Runcorn		HS2 CC	200m	
HS2	HS08b	London Euston (HS2)	Preston / Lancaster	HS2, Crewe, West Coast	Old Oak Common, Birmingham Interchange, Warrington Bank Quay, Wigan North West, Preston		HS2 CC	200m	
HS2	HS10	London Euston (HS2)	Glasgow Central	WCML	Old Oak Common, Birmingham Interchange, Preston	Hourly	HS2 CC	200m	
HS2	HS09	London Euston (HS2)	Macclesfield	Handsacre, Stafford, Stoke	Old Oak Common, Birmingham Interchange, Preston	Hourly	HS2 CC	200m	
Euston Long Distance	LD01	London Euston	Manchester Piccadilly	Weedon / Trent Valley /	Milton Keynes, Rugby, Stoke, Macclesfield	Half Hourly		807	7
Euston Long Distance	LD02	London Euston	Manchester Piccadilly	Weedon / Trent Valley /	Watford Junction, Milton Keynes, Nuneaton, Tamworth, Lichfield, Stoke, Macclesfield			807	7
Euston Long Distance	LD03	London Euston	Chester / Holyhead	Weedon / Trent Valley	Milton Keynes, Stafford, Crewe	Hourly		805	10
Euston Long Distance	LD04	London Euston	Glasgow Central / Edinburgh	Weedon / West Midlands	Watford Junction, Milton Keynes, Rugby, Coventry, Birmingham International, Birmingham New Street, Sandwell and Dudley, Wolverhampton, Crewe, Warrington Bank Quay, Wigan North Western, Preston, Lancaster, (Oxenholme), (Penrith North Lakes), Carlisle (Lockerbie)	Half Hourly		807	7
Euston Long Distance	LD05	London Euston	Shrewsbury	Weedon / West Midlands	Watford Junction, Milton Keynes, Rugby, Coventry, Birmingham International, Birmingham New Street, Wolverhampton, Telford, Wellington			805	10
Euston Long Distance	LD06	London Euston	Liverpool	Weedon / Trent Valley	Watford Junction, Milton Keynes, Rugby, Nuneaton, Tamworth, Lichfield, Stafford, Crewe, Runcorn, Liverpool South Parkway	Half Hourly (if both services are in the plan)		807	7
Euston Long Distance	LD07	London Euston	Liverpool	Weedon / Trent Valley / Hixon	Milton Keynes, Rugby, Stafford, Crewe, Runcorn, Liverpool South Parkway			807	7
Euston Long Distance	LD08	London Euston	Birmingham New Street		Milton Keynes, Northampton, Coventry, Birmingham International	Half Hourly		807	7
Euston Long Distance	LD09	London Euston	Birmingham New Street		Milton Keynes, Northampton, Coventry, Birmingham International			807	7
Birmingham Interregion	LD10	Birmingham New Street	Liverpool	Cov Corridor / West Midlands	Wolverhampton, Stafford, Crewe, Runcorn, Liverpool South Parkway	Hourly		807	7
Birmingham Interregion	LD11	Birmingham New Street	Shrewsbury / Wales		Smethwick Galton Bridge, Wolverhampton, Telford, Wellington	Hourly		805	10

West Midlands	WM01	Coventry	Wolverhampton	Tile Hill, Hampton in Arden, Birmingham International, Marston Green, Lea Hall, Stechford, Adderly Park, Birmingham New Street, Smethwick Rolfe Street, Smethwick Galton Bridge, Sandwell and Dudley, Dudley Port, Coseley	Half Hourly	350-110	8		
West Midlands	WM02	Coventry	Wolverhampton	Tile Hill, Berkswell, Hampton in Arden, Birmingham International, Marston Green, Lea Hall, Stechford, Birmingham New Street, Smethwick Rolfe Street, Smethwick Galton Bridge, Sandwell and Dudley, Dudley Port, Coseley					
West Midlands	WM03	Northampton	Wolverhampton	Long Buckby, Rugby Parkway, Rugby, Coventry East, Coventry, Canley, Tile Hill, Berkswell, Birmingham International, Marston Green, Birmingham New Street, Smethwick Rolfe Street, Smethwick Galton Bridge, Sandwell and Dudley, Dudley Port, Tipton, Coseley	Half Hourly	350-110	8		
West Midlands	WM04	Northampton	Wolverhampton	Long Buckby, Rugby Parkway, Rugby, Coventry East, Coventry, Canley, Tile Hill, Birmingham International, Marston Green, Adderly Park, Birmingham New Street, Smethwick Rolfe Street, Smethwick Galton Bridge, Sandwell and Dudley, Dudley Port, Tipton, Coseley					
West Midlands	WM05	Birmingham New Street	Stafford	Tame Bridge Parkway, Walsall, Bloxwich, Bloxwich North, Ladywood, Cannock, Hednesford, Rugeley Town, Rugeley Trent Valley	Half Hourly (if both services are in the plan)	350-110	8		
West Midlands	WM06	Birmingham New Street	Rugeley Trent Valley	Tame Bridge Parkway, Walsall, Bloxwich, Bloxwich North, Ladywood, Cannock, Hednesford, Rugeley Town					
Euston Suburban	SU01	London Euston	Crewe	Watford Junction, Berkhamstead, Leighton Buzzard, Milton Keynes, Northampton, Long Buckby, Rugby, Nuneaton, Atherstone, Polesworth, Tamworth, Lichfield, Rugeley Trent Valley, Stafford	Half Hourly (to/from Rugby)	350-110	8		
Euston Suburban	SU02	London Euston	Rugby	Hemel Hempstead, Leighton Buzzard, Bletchley, Milton Keynes, Northampton, Rugby Parkway,					
Euston Suburban	SU03	London Euston	Northampton	Watford Junction, Kings Langley, Apsley, Hemel Hempstead, Berkhamstead, Tring, Cheddington, Leighton Buzzard, Bletchley, Milton Keynes, Wolverton	Half Hourly	350-110	12		
Euston Suburban	SU04	London Euston	Northampton	Watford Junction, Kings Langley, Apsley, Hemel Hempstead, Berkhamstead, Tring, Leighton Buzzard, Bletchley, Milton Keynes, Wolverton					
Euston Suburban	SU05	London Euston	Tring	Wembley Central, Harrow, Bushey, Watford Junction, Kings Langley, Apsley, Hemel Hempstead, Berkhamstead	Half Hourly	350-110	12		
Euston Suburban	SU06	London Euston	Tring	Wembley Central, Harrow, Bushey, Watford Junction, Kings Langley, Apsley, Hemel Hempstead, Berkhamstead					
DC Line	DC01	London Euston	Watford Junction	All stops DC	15-Minute Pattern	710	5		
DC Line	DC02	London Euston	Watford Junction	All stops DC					
DC Line	DC03	London Euston	Watford Junction	All stops DC					
DC Line	DC04	London Euston	Watford Junction	All stops DC					
West London Suburban	WL01	East Croydon	Milton Keynes	Wembley Central, Harrow, Bushey, Watford Junction, Hemel Hempstead, Berkhamstead, Tring, Leighton Buzzard, Bletchley	Half Hourly (if both services are in the plan)	377	8		
West London Suburban	WL02	East Croydon	Watford Junction	Wembley Central, Harrow, Bushey					

East West Rail	EW01	Oxford	Milton Keynes		Bletchley		Half Hourly	350-110	8	
East West Rail	EW02	Oxford	Milton Keynes		Bletchley			350-110	8	
East West Rail	EW03	Aylesbury	Milton Keynes		Bletchley		Half Hourly	350-110	8	
East West Rail	EW04	Aylesbury	Milton Keynes		Bletchley		(if both services are in the plan)	350-110	8	
East West Rail	EW05	Cambridge	Milton Keynes				Half Hourly	350-110	8	
East West Rail	EW06	Cambridge	Milton Keynes				(if both services are in the plan)	350-110	8	
CrossCountry	XC01	Reading	Manchester Piccadilly	Coventry Corridor	Coventry, Birmingham International, Birmingham New Street, Wolverhampton, Stafford, Stoke, Macclesfield		Half Hourly	220-110	8	
CrossCountry	XC02	Bristol Temple Meads	Manchester Piccadilly		Birmingham New Street, Wolverhampton, Stafford, Stoke, Macclesfield		(to/from Birmingham)	220-110	8	
CrossCountry	XC03	Reading	Newcastle Upon Tyne	Coventry Corridor	Coventry, Birmingham International, Birmingham New Street			220-110	8	
Crewe Terminators	CR01	Derby	Crewe	Alsager	Tutbury & Hatton, Uttoxeter, Blythe Bridge, Longton, Stoke-on-Trent, Longport, Kidsgrove, Alsager		Hourly	170	2	
Crewe Terminators	CR02	Birmingham New Street	Crewe	Stafford / Norton Bridge	Tame Bridge Parkway, Darlaston, Willenhall, Wolverhampton, Penkridge, Stafford, Stone, Stoke South Stoke, Kidsgrove, Alsager		Half Hourly	350-110	4	
Crewe Terminators	CR03	Birmingham New Street	Stoke-on-Trent	Stafford / Norton Bridge	Tame Bridge Parkway, Darlaston, Willenhall, Wolverhampton, Penkridge, Stafford, Stone, Stoke South			350-110	4	
Northern	NT01	Stoke	Manchester Piccadilly	Cheadle Hulme	Longport, Kidsgrove, Congleton, Macclesfield, Prestbury, Adlington, Poynton, Bramhall, Cheadle Hulme, Stockport		Hourly	323	3	
Freight	FR01	Camden Junction	Birmingham Terminals		via Northampton and Nuneaton		Hourly	90	775m / 1800t	Class 4
Freight	FR02a	Wembley Central	Birmingham Terminals		via Northampton and Nuneaton		Hourly	90	775m / 1800t	Class 4
Freight	FR02b	Wembley Central	Daventry		via Northampton		Hourly	90	775m / 1800t	Class 4
Freight	FR03	Wembley Central	Crewe		via Northampton, Trent Valley and Stafford		Hourly	90	775m / 1800t	Class 4
Freight	FR04	Camden Junction	Crewe		via Northampton, Trent Valley and Stafford		Hourly	90	775m / 1800t	Class 4
Freight	FR05a	Wembley Central	Birmingham Terminals		via Northampton and Nuneaton		Hourly	90	450m / 2600t	Class 6
Freight	FR05b	Wembley Central	Stone		via Northampton and Hixon		Hourly	90	450m / 2600t	Class 6
Freight	FR05c	Wembley Central	Crewe		via Northampton, Trent Valley and Stafford		Hourly	90	450m / 2600t	Class 6
Freight	FR06a	Wembley Central	Birmingham Terminals		via Northampton (or Weedon) and Nuneaton		Hourly	325	250m / 600t	Class 1
Freight	FR06b	Wembley Central	Crewe		via Northampton (or Weedon), Trent Valley and Stafford		Hourly	325	250m / 600t	Class 1
Freight	FR07	Hinckley	Crewe		via Nuneaton, Trent Valley and Stafford		Hourly	90	450m / 2600t	Class 6
Freight	FR08	Hinckley	Crewe		via Nuneaton, Trent Valley and Stafford		Hourly	90	775m / 1800t	Class 4
Freight	FR09	Hinckley	Birmingham Terminals		via Nuneaton		Hourly	90	775m / 1800t	Class 4
Freight	FR10	Hinckley	Birmingham Terminals		via Nuneaton		Hourly	90	775m / 1800t	Class 4
Freight	FR11	Denbigh Hall South Junction	Daventry		via East West Rail, Northampton		Hourly	90	775m / 1800t	Class 4
Freight	FR12a	Daventry	Birmingham Terminals		via Nuneaton		Hourly	90	775m / 1800t	Class 4
Freight	FR12b	Daventry	Crewe		via Trent Valley and Stafford		Hourly	90	775m / 1800t	Class 4
Freight	FR13	Southampton	Crewe		via Coventry, Nuneaton, Trent Valley and Stafford		Hourly	90	775m / 1800t	Class 4
Freight	FR14	Southampton	Crewe		via Birmingham, Bushbury Junction and Stafford		Hourly	90	775m / 1800t	Class 4
Freight	FR15a	Birmingham Terminals	Crewe		via Bushbury Junction and Stafford		Hourly	90	450m / 2600t	Class 6*
Freight	FR15b	Birmingham Terminals	Stone		via Bushbury Junction, Stafford and Norton Bridge		Hourly	90	450m / 2600t	Class 6
Freight	FR16	Denbigh Hall South Junction	Crewe		via East West Rail, Northampton, Trent Valley and Stafford		Hourly	90	775m / 1800t	Class 4
Freight	FR17	Cannock	Crewe		via Rugeley North Jn. and Stafford		Hourly	90	775m / 1800t	Class 4
Freight	FR18	Daventry	Crewe		via Trent Valley and Stafford		Hourly	325	250 / 600t	Class 1

Freight Focus Released Capacity Train Plan – Generalised Journey Time Results

Figures show Generalised Journey Times in minutes between tested locations.

	XLD	WFJ	HML	LBZ	MKC	RUG	NMP	COV	XBH	NUN	TAM	LTV	WVH	SHR	STA	SOT	CRE	XLP	XMC	CBG	BDM	OXF	
XLD		69.5	96.9	96.9	110.3	78.8	117.9	117.5	118.4	93.6	106.4	112.4	136.6	185.5	112.5	145.4	152.2	207.0	92.3	122.3	102.0	140.1	
WFJ			20.3	34.6	33.5	64.2	60.5	99.8	143.6	75.6	86.0	92.2	115.6	169.3	118.4	117.9	132.4	187.1	171.3	310.5	139.9	107.5	
HML				31.1	43.5	87.3	63.1	109.7	145.6	112.7	127.4	135.2	166.8	229.2	157.7	164.1	165.7	232.9	190.1	320.5	134.1	141.3	
LBZ					20.3	59.2	37.6	75.9	178.1	85.5	98.4	105.8	143.3	206.9	122.8	141.7	138.6	218.5	190.4	309.6	107.8	112.2	
MKC						33.4	24.8	57.7	111.3	49.4	57.7	63.9	94.4	147.0	80.1	98.7	89.4	175.9	141.7	256.2	104.5	59.3	
RUG							32.5	22.4	48.2	33.9	47.6	54.5	74.7	125.8	71.0	77.2	88.6	132.1	127.3	252.2	168.5	73.6	
NMP								48.3	78.9	65.8	79.2	86.8	114.5	183.9	102.6	130.7	123.6	231.2	209.3	308.4	133.5	111.8	
COV									33.6	45.6	64.6	71.6	61.5	115.3	88.2	101.5	105.9	197.0	130.1	260.9	182.8	79.1	
XBH										52.9	41.3	54.9	25.8	80.2	48.3	73.3	72.0	120.3	68.6	194.3	189.1	91.2	
NUN											25.7	32.8	89.8	156.8	58.7	67.9	76.4	119.8	122.9	164.6	159.4	87.4	
TAM												17.6	79.3	143.3	46.7	54.4	64.6	109.9	108.4	266.5	205.7	94.5	
LTV													80.5	151.0	40.4	47.1	57.8	104.0	102.0	275.2	237.4	100.8	
WVH														61.5	26.7	53.4	47.7	99.8	95.9	281.4	265.9	127.9	
SHR															101.6	124.1	68.7	143.3	112.6	346.8	341.6	220.1	
STA																35.5	33.6	79.6	82.1	295.3	262.1	137.8	
SOT																	49.6	119.6	65.7	257.1	258.5	150.9	
CRE																		60.8	99.1	313.9	280.5	129.4	
XLP																			60.7	389.8	361.6	239.5	
XMC																				296.5	297.0	182.6	
CBG																						210.5	389.1
BDM																							262.4
OXF																							

Freight Focus With Infrastructure Train Plan – Generalised Journey Time Results

Figures show Generalised Journey Times in minutes between tested locations.

	EUS	WFJ	HML	LBZ	MKC	RUG	NMP	COV	BHM	NUN	TAM	LTV	WVH	SHR	STA	SOT	CRE	LIV	MAN	CBG	BDM	OXF
EUS		69.5	96.9	96.9	110.3	78.8	117.9	117.5	118.4	93.6	106.4	112.4	136.6	185.5	112.5	145.4	152.2	207.0	92.3	122.3	102.0	140.1
WFJ			20.3	34.6	33.5	64.2	60.5	99.8	143.6	75.6	86.0	92.2	115.6	169.3	118.4	117.9	132.4	187.1	171.3	137.0	83.0	107.5
HML				31.1	43.5	87.3	63.1	109.7	145.6	112.7	127.4	135.2	166.8	229.2	157.7	164.1	165.7	232.9	190.1	130.2	76.2	141.3
LBZ					20.3	59.2	37.6	75.9	178.1	85.5	98.4	105.8	143.3	206.9	122.8	141.7	138.6	218.5	190.4	109.2	55.2	112.2
MKC						33.4	24.8	57.7	111.3	49.4	57.7	63.9	94.4	147.0	80.1	98.7	89.4	175.9	141.7	90.0	47.5	59.3
RUG							32.5	22.4	48.2	33.9	47.6	54.5	74.7	125.8	71.0	77.2	88.6	132.1	127.3	166.0	112.0	73.6
NMP								48.3	78.9	65.8	79.2	86.8	114.5	183.9	102.6	130.7	123.6	231.2	209.3	135.7	91.2	111.8
COV									33.6	45.6	64.6	71.6	61.5	115.3	88.2	101.5	105.9	197.0	130.1	178.8	124.8	73.1
BHM										52.9	41.3	54.9	25.8	80.2	48.3	73.3	72.0	120.3	68.6	207.3	182.9	91.2
NUN											25.7	32.8	89.8	156.8	58.7	67.9	76.4	119.8	122.9	183.8	129.8	87.4
TAM												17.6	79.3	143.3	46.7	54.4	64.6	109.9	108.4	198.4	144.4	94.5
LTV													80.5	151.0	40.4	47.1	57.8	104.0	102.0	205.2	151.2	100.8
WVH														61.5	26.7	53.4	47.7	99.8	95.9	247.8	193.8	127.9
SHR															101.6	124.1	68.7	143.3	112.6	343.3	289.3	220.1
STA																35.5	33.6	79.6	82.1	246.2	192.2	137.8
SOT																	49.6	119.6	65.7	261.7	207.7	150.9
CRE																		60.8	99.1	252.9	198.9	129.4
LIV																			60.7	347.5	293.5	239.5
MAN																				289.6	235.6	182.6
CBG																					184.5	278.4
BDM																						228.0
OXF																						

Appendix D – Intermediate Markets ITSS and Generalised Journey Times

Base ITSS

Service Type	Code	From	To	Route	Calling Pattern	Pattern	Rolling stock	Length	Class
HS2	HS01	London Euston (HS2)	Birmingham Curzon Street	HS2	Old Oak Common, Birmingham Interchange	20-Minute Pattern	HS2 CC	400m	
HS2	HS02	London Euston (HS2)	Birmingham Curzon Street	HS2	Old Oak Common, Birmingham Interchange		HS2 CC	400m	
HS2	HS03	London Euston (HS2)	Birmingham Curzon Street	HS2	Old Oak Common, Birmingham Interchange	20-Minute Pattern	HS2 CC	400m	
HS2	HS04	London Euston (HS2)	Manchester Piccadilly	HS2, Crewe, Wilmslow	Old Oak Common, Wilmslow, Stockport		HS2 CC	200m	
HS2	HS05	London Euston (HS2)	Manchester Piccadilly	HS2, Crewe, Wilmslow	Old Oak Common, Crewe, Stockport,		HS2 CC	200m	
HS2	HS06	London Euston (HS2)	Manchester Piccadilly	HS2, Crewe, Wilmslow	Old Oak Common, Stockport		HS2 CC	200m	
HS2	HS07	London Euston (HS2)	Liverpool	Runcorn WCML and HS2	Old Oak Common, Crewe, Runcorn	Half Hourly	HS2 CC	200m	
HS2	HS08a	London Euston (HS2)	Liverpool	Runcorn WCML and HS2	Old Oak Common, Crewe, Runcorn		HS2 CC	200m	
HS2	HS08b	London Euston (HS2)	Preston / Lancaster	HS2, Crewe, West Coast	Old Oak Common, Birmingham Interchange, Warrington Bank Quay, Wigan North West, Preston	Hourly	HS2 CC	200m	
HS2	HS10	London Euston (HS2)	Glasgow Central	WCML	Old Oak Common, Birmingham Interchange, Preston	Hourly	HS2 CC	200m	
HS2	HS09	London Euston (HS2)	Macclesfield	Handsacre, Stafford, Stoke	Old Oak Common, Birmingham Interchange, Preston	Hourly	HS2 CC	200m	
Euston Long Distance	LD01	London Euston	Shrewsbury		Watford Junction, Hemel Hempstead, Milton Keynes Central, Coventry, Birmingham International, Birmingham New Street, Sandwell and Dudley, Wolverhampton, Telford Central, Wellington	Half Hourly	805	10	
Euston Long Distance	LD02	London Euston	Glasgow Central		Watford Junction, Leighton Buzzard, Milton Keynes Central, Coventry, Birmingham International, Birmingham New Street, Wolverhampton, Crewe, Warrington Bank Quay (to Scotland)		807	7	
Euston Long Distance	LD03	London Euston	Birmingham New Street		Northampton, Rugby, Coventry, Birmingham International	Half Hourly	807	7	
Euston Long Distance	LD04	London Euston	Birmingham New Street		Northampton, Rugby, Coventry, Birmingham International		807	7	
Birmingham Interregion	LD05	Birmingham New Street	Liverpool Lime Street		Wolverhampton, Stafford, Crewe, Runcorn, Liverpool South Parkway	Hourly	807	7	
Birmingham Interregion	LD06	Birmingham New Street	Shrewsbury		Smethwick Galton Bridge, Wolverhampton, Telford Central, Wellington	Half Hourly with LD01	805	10	
Euston Long Distance	LD07	London Euston	Macclesfield		Milton Keynes Central, Stoke-on-Trent	Half Hourly	807	7	
Euston Long Distance	LD08	London Euston	Manchester Piccadilly		Milton Keynes Central, Stoke-on-Trent		807	7	
Euston Long Distance	LD09	London Euston	Manchester Piccadilly		Watford Junction, Milton Keynes Central, Nuneaton, Tamworth, Lichfield Trent Valley, Stoke-on-Trent	Half Hourly	807	7	
Euston Long Distance	LD10	London Euston	Liverpool Lime Street		Milton Keynes Central, Rugby, Nuneaton, Tamworth, Lichfield Trent Valley, Crewe, Runcorn, Liverpool South Parkway		807	7	
Euston Long Distance	LD11	London Euston	Chester		Hemel Hempstead, Milton Keynes Central, Stafford, Crewe	Half Hourly	805	10	
Euston Long Distance	LD12	London Euston	Crewe		Leighton Buzzard, Milton Keynes Central, Stafford		805	10	

Euston Long Distance	LD13	London Euston	Crewe	Bletchley, Milton Keynes Central, Rugby, Nuneaton, Atherstone, Polesworth, Tamworth, Lichfield Trent Valley, Rugeley, Stafford	Half Hourly	350-110	4	
Euston Long Distance	LD14	London Euston	Stoke-on-Trent	Bletchley, Milton Keynes Central, Rugby, Nuneaton, Atherstone, Polesworth, Tamworth, Lichfield Trent Valley, Rugeley		350-110	4	
Euston Suburban	SU01	London Euston	Rugby	Watford Junction, Hemel Hempstead, Berkhamstead, Leighton Buzzard, Bletchley, Milton Keynes Central, Wolverton, Northampton, Long Buckby, Rugby Parkway	Half Hourly	350-110	8	
Euston Suburban	SU02	London Euston	Rugby	Watford Junction, Hemel Hempstead, Berkhamstead, Leighton Buzzard, Bletchley, Milton Keynes Central, Wolverton, Northampton, Long Buckby, Rugby Parkway		350-110	8	
Euston Suburban	SU03	London Euston	Milton Keynes Central	Watford Junction, Kings Langley, Apsley, Hemel Hempstead, Berkhamstead, Tring, Cheddington, Leighton Buzzard, Bletchley	Half Hourly	350-110	12	
Euston Suburban	SU04	London Euston	Milton Keynes Central	Watford Junction, Kings Langley, Apsley, Hemel Hempstead, Berkhamstead, Tring, Leighton Buzzard, Bletchley		350-110	12	
Euston Suburban	SU05	London Euston	Tring	Wembley Central, Harrow and Wealdstone, Bushey, Watford Junction, Kings Langley, Apsley, Hemel Hempstead, Berkhamstead	Half Hourly	350-110	12	
Euston Suburban	SU06	London Euston	Tring	Wembley Central, Harrow and Wealdstone, Bushey, Watford Junction, Kings Langley, Apsley, Hemel Hempstead, Berkhamstead		350-110	12	
East West Rail	EW01	Oxford	Northampton	Bletchley, Milton Keynes Central, Wolverton	Half Hourly	350-110	4	
East West Rail	EW02	Oxford	Northampton	Bletchley, Milton Keynes Central, Wolverton		350-110	4	
East West Rail	EW03	Cambridge	Milton Keynes Central		Half Hourly	350-110	4	
East West Rail	EW04	Cambridge	Milton Keynes Central			350-110	4	
East West Rail	EW05	Aylesbury	Milton Keynes Central	Bletchley	Half Hourly	350-110	4	
East West Rail	EW06	Aylesbury	Milton Keynes Central	Bletchley		350-110	4	
West Midlands	WM01	Coventry	Wolverhampton	Tile Hill, Hampton in Arden, Birmingham International, Marston Green, Lea Hall, Stechford, Adderly Park, Birmingham New Street, Smethwick Rolfe Street, Smethwick Galton Bridge, Sandwell and Dudley, Dudley Port, Coseley	Half Hourly	350-110	8	
West Midlands	WM02	Coventry	Wolverhampton	Tile Hill, Berkswell, Hampton in Arden, Birmingham International, Marston Green, Lea Hall, Stechford, Birmingham New Street, Smethwick Rolfe Street, Smethwick Galton Bridge, Sandwell and Dudley, Dudley Port, Coseley		350-110	8	
West Midlands	WM03	Northampton	Wolverhampton	Long Buckby, Rugby Parkway, Rugby, Coventry East, Coventry, Canley, Tile Hill, Berkswell, Birmingham International, Marston Green, Birmingham New Street, Smethwick Rolfe Street, Smethwick Galton Bridge, Sandwell and Dudley, Dudley Port, Tipton, Coseley	Half Hourly	350-110	8	
West Midlands	WM04	Northampton	Wolverhampton	Long Buckby, Rugby Parkway, Rugby, Coventry East, Coventry, Canley, Tile Hill, Birmingham International, Marston Green, Adderly Park, Birmingham New Street, Smethwick Rolfe Street, Smethwick Galton Bridge, Sandwell and Dudley, Dudley Port, Tipton, Coseley		350-110	8	

West Midlands	WM05	Birmingham New Street	Stafford		Tame Bridge Parkway, Walsall, Bloxwich, Bloxwich North, Ladywood, Cannock, Hednesford, Rugeley Town, Rugeley Trent Valley	Half Hourly (if both services are in the plan)	350-110	4	
West Midlands	WM06	Birmingham New Street	Stafford		Tame Bridge Parkway, Walsall, Bloxwich, Bloxwich North, Ladywood, Cannock, Hednesford, Rugeley Town, Rugeley Trent Valley		350-110	4	
Cross Country	XC01	Reading	Manchester Piccadilly		Coventry, Birmingham International, Birmingham New Street, Sandwell and Dudley, Wolverhampton, Stafford, Stoke-on-Trent, Macclesfield	Half Hourly (to/from Birmingham)	220-110	8	
Cross Country	XC02	Bristol Temple Meads	Manchester Piccadilly		Birmingham New Street, Smethwick Galton Bridge, Wolverhampton, Stafford, Stoke-on-Trent, Macclesfield		220-110	8	
Cross Country	XC03	Reading	Newcastle		Coventry, Birmingham International, Birmingham New Street		220-110	8	
West London Line	WL01	East Croydon	Milton Keynes Central		Wembley Central, Harrow and Wealdstone, Bushey, Watford Junction, Hemel Hempstead, Berkhamstead, Tring, Leighton Buzzard, Bletchley	Half Hourly	377	8	
West London Line	WL02	East Croydon	Milton Keynes Central		Wembley Central, Harrow and Wealdstone, Bushey, Watford Junction, Hemel Hempstead, Berkhamstead, Tring, Leighton Buzzard, Bletchley		377	8	
DC Line	DC01	London Euston	Watford Junction		All stops DC	15-Minute Pattern	710	5	
DC Line	DC02	London Euston	Watford Junction		All stops DC		710	5	
DC Line	DC03	London Euston	Watford Junction		All stops DC		710	5	
DC Line	DC04	London Euston	Watford Junction		All stops DC		710	5	
Crewe Terminators	CR01	Derby	Crewe		Tutbury & Hatton, Uttoxeter, Blythe Bridge, Longton, Stoke-on-Trent, Longport, Kidsgrove, Alsager	Hourly	170	2	
Crewe Terminators	CR02	Birmingham New Street	Crewe		Tame Bridge Parkway, Darlston, Willenhall, Wolverhampton, Penkridge, Stafford, Stone, Stoke South, Stoke-on-Trent, Kidsgrove, Alsager	Half Hourly	350-110	4	
Crewe Terminators	CR03	Birmingham New Street	Stoke-on-Trent		Tame Bridge Parkway, Darlston, Willenhall, Wolverhampton, Penkridge, Stafford, Stone, Stoke South		350-110	4	
Northern	NT01	Stoke	Manchester Piccadilly	Cheadle Hulme	Longport, Kidsgrove, Congleton, Macclesfield, Prestbury, Adlington, Poynton, Bramhall, Cheadle Hulme, Stockport	Hourly	323	3	
Freight	FR01	Camden Junction	Birmingham Terminals		via Northampton and Nuneaton	Hourly	90	775m / 1800t	Class 4
Freight	FR02a	Wembley Central	Birmingham Terminals		via Northampton and Nuneaton	Hourly	90	775m / 1800t	Class 4
Freight	FR02b	Wembley Central	Daventry		via Northampton	Hourly	90	775m / 1800t	Class 4
Freight	FR03	Wembley Central	Crewe		via Northampton, Trent Valley and Stafford	Hourly	90	775m / 1800t	Class 4
Freight	FR04	Camden Junction	Crewe		via Northampton, Trent Valley and Stafford	Hourly	90	775m / 1800t	Class 4
Freight	FR05a	Wembley Central	Birmingham Terminals		via Northampton and Nuneaton	Hourly	90	450m / 2600t	Class 6
Freight	FR05b	Wembley Central	Stone		via Northampton and Hixon	Hourly	90	450m / 2600t	Class 6
Freight	FR05c	Wembley Central	Crewe		via Northampton, Trent Valley and Stafford	Hourly	90	450m / 2600t	Class 6
Freight	FR06a	Wembley Central	Birmingham Terminals		via Northampton (or Weedon) and Nuneaton	Hourly	325	250m / 600t	Class 1
Freight	FR06b	Wembley Central	Crewe		via Northampton (or Weedon), Trent Valley and Stafford	Hourly	325	250m / 600t	Class 1
Freight	FR07	Hinckley	Crewe		via Nuneaton, Trent Valley and Stafford	Hourly	90	450m / 2600t	Class 6
Freight	FR08	Hinckley	Crewe		via Nuneaton, Trent Valley and Stafford	Hourly	90	775m / 1800t	Class 4
Freight	FR09	Hinckley	Birmingham Terminals		via Nuneaton	Hourly	90	775m / 1800t	Class 4
Freight	FR10	Hinckley	Birmingham Terminals		via Nuneaton	Hourly	90	775m / 1800t	Class 4
Freight	FR11	Denbigh Hall South Junction	Daventry		via East West Rail, Northampton	Hourly	90	775m / 1800t	Class 4
Freight	FR12a	Daventry	Birmingham Terminals		via Nuneaton	Hourly	90	775m / 1800t	Class 4
Freight	FR12b	Daventry	Crewe		via Trent Valley and Stafford	Hourly	90	775m / 1800t	Class 4
Freight	FR13	Southampton	Crewe		via Coventry, Nuneaton, Trent Valley and Stafford	Hourly	90	775m / 1800t	Class 4
Freight	FR14	Southampton	Crewe		via Birmingham, Bushbury Junction and Stafford	Hourly	90	775m / 1800t	Class 4
Freight	FR15a	Birmingham Terminals	Crewe		via Bushbury Junction and Stafford	Hourly	90	450m / 2600t	Class 6*
Freight	FR15b	Birmingham Terminals	Stone		via Bushbury Junction, Stafford and Norton Bridge	Hourly	90	450m / 2600t	Class 6

Intermediate Markets Released Capacity Train Plan - Generalised Journey Time Results

Figures show Generalised Journey Times in minutes between tested locations.

	EUS	WFJ	HML	LBZ	MKC	RUG	NMP	COV	BHM	NUN	TAM	LTV	WVH	SHR	STA	SOT	CRE	LIV	MAN	CBG	BDM	OXF	
EUS		73.9	86.7	98.4	92.7	78.7	110.9	116.1	118.2	93.3	107.9	113.8	137.5	192.0	125.8	151.9	155.2	189.3	92.3	122.3	102.0	140.1	
WFJ			20.6	40.8	37.7	84.3	68.9	100.9	146.1	100.7	116.8	123.9	122.8	177.9	146.3	149.7	150.5	226.5	185.6	310.5	139.9	107.5	
HML				40.5	40.0	88.0	71.0	78.1	130.9	107.9	125.4	133.5	125.3	170.8	103.6	162.8	123.7	219.8	188.1	320.5	134.1	141.3	
LBZ					23.3	64.0	44.3	73.8	122.9	92.2	105.8	114.1	134.2	207.5	117.8	155.5	134.8	224.2	187.4	309.6	107.8	112.2	
MKC						33.8	27.7	55.3	110.1	49.0	59.8	66.4	98.2	150.2	84.9	106.1	92.0	156.4	143.3	256.2	104.5	59.3	
RUG							34.2	25.0	52.1	29.8	42.8	49.9	94.1	154.2	78.7	88.9	84.8	128.3	137.5	252.2	168.5	73.6	
NMP								47.9	76.3	69.1	85.9	94.1	127.9	186.9	122.0	140.2	136.8	243.9	178.4	308.4	133.5	111.8	
COV									34.2	45.7	65.7	72.5	66.6	121.6	91.1	105.3	102.5	216.1	132.7	260.9	182.8	79.1	
BHM										52.9	41.3	55.1	26.4	79.8	48.2	72.4	70.1	120.3	68.6	194.3	189.1	91.2	
NUN											25.3	32.2	94.1	157.0	66.2	67.6	73.0	115.3	117.7	164.6	159.4	87.4	
TAM												16.6	80.2	145.6	51.3	53.7	60.4	103.0	101.2	266.5	205.7	94.5	
LTV													81.7	150.5	44.6	46.5	53.9	97.8	96.0	275.2	237.4	100.8	
WVH														60.8	28.8	54.1	45.6	100.0	95.8	281.4	265.9	127.9	
SHR															96.4	121.4	68.7	142.8	112.6	346.8	341.6	220.1	
STA																35.7	32.6	80.5	82.1	295.3	262.1	137.8	
SOT																	48.4	120.3	60.4	257.1	258.5	150.9	
CRE																		57.6	99.1	313.9	280.5	129.4	
LIV																				60.7	389.8	361.6	239.5
MAN																					296.5	297.0	182.6
CBG																						210.5	389.1
BDM																							262.4
OXF																							

Intermediate Markets With Infrastructure Train Plan - Generalised Journey Time Results

Figures show Generalised Journey Times in minutes between tested locations.

	XLD	WFJ	HML	LBZ	MKC	RUG	NMP	COV	XBH	NUN	TAM	LTV	WVH	SHR	STA	SOT	CRE	XLP	XMC	CBG	BDM	OXF
XLD		73.2	86.7	98.4	92.7	78.7	110.9	116.1	118.2	93.3	107.9	113.8	137.5	192.0	125.8	151.9	155.2	189.3	92.3	122.3	102.0	140.1
WFJ			20.4	39.8	37.7	84.3	68.9	100.9	145.9	100.7	116.8	123.9	122.8	177.9	146.3	149.7	150.4	226.3	185.4	137.0	83.0	107.5
HML				35.9	39.1	87.7	70.6	78.1	132.7	107.8	125.3	133.3	125.3	170.8	103.6	162.4	123.7	219.8	187.8	130.2	76.2	141.3
LBZ					19.8	63.1	44.0	73.4	122.6	89.4	103.6	112.0	131.8	204.8	116.2	150.0	134.1	222.3	186.9	109.2	55.2	112.2
MKC						33.8	27.7	55.3	110.1	49.0	59.8	66.4	98.2	150.2	84.9	106.1	92.0	156.4	143.3	90.0	47.5	59.3
RUG							34.2	25.0	52.1	29.8	42.8	49.9	94.1	154.2	78.7	88.9	84.8	128.3	137.5	166.0	112.0	73.6
NMP								47.9	76.3	69.1	85.9	94.1	127.9	186.9	122.0	140.2	136.8	243.9	178.4	135.7	91.2	111.8
COV									34.2	45.7	65.7	72.5	66.6	121.6	91.1	105.3	102.5	216.1	132.7	178.8	124.8	73.1
XBH										52.9	41.3	55.1	26.4	79.8	48.2	72.4	70.1	120.3	68.6	207.3	182.9	91.2
NUN											25.3	32.2	94.1	157.0	66.2	67.6	73.0	115.3	117.7	183.8	129.8	87.4
TAM												16.6	80.2	145.6	51.3	53.7	60.4	103.0	101.2	198.4	144.4	94.5
LTV													81.7	150.5	44.6	46.5	53.9	97.8	96.0	205.2	151.2	100.8
WVH														60.8	28.8	54.1	45.6	100.0	95.8	247.8	193.8	127.9
SHR															96.4	121.4	68.7	142.8	112.6	343.3	289.3	220.1
STA																35.7	32.6	80.5	82.1	246.2	192.2	137.8
SOT																	48.4	120.3	60.4	261.7	207.7	150.9
CRE																		57.6	99.1	252.9	198.9	129.4
XLP																			60.7	347.5	293.5	239.5
XMC																				289.6	235.6	182.6
CBG																					184.5	278.4
BDM																						228.0
OXF																						

Appendix E - East West Connectivity ITSS and Generalised Journey Times

Base ITSS

Service Type	Code	From	To	Route	Calling Pattern	Pattern	Rolling stock	Length	Class
HS2	HS01	London Euston (HS2)	Birmingham Curzon Street	HS2	Old Oak Common, Birmingham Interchange	20-Minute Pattern	HS2 CC	400m	
HS2	HS02	London Euston (HS2)	Birmingham Curzon Street	HS2	Old Oak Common, Birmingham Interchange		HS2 CC	400m	
HS2	HS03	London Euston (HS2)	Birmingham Curzon Street	HS2	Old Oak Common, Birmingham Interchange		HS2 CC	400m	
HS2	HS04	London Euston (HS2)	Manchester Piccadilly	HS2, Crewe, Wilmslow	Old Oak Common, Wilmslow, Stockport	20-Minute Pattern	HS2 CC	200m	
HS2	HS05	London Euston (HS2)	Manchester Piccadilly	HS2, Crewe, Wilmslow	Old Oak Common, Crewe, Stockport,		HS2 CC	200m	
HS2	HS06	London Euston (HS2)	Manchester Piccadilly	HS2, Crewe, Wilmslow	Old Oak Common, Stockport		HS2 CC	200m	
HS2	HS07	London Euston (HS2)	Liverpool	Runcorn WCML and HS2	Old Oak Common, Crewe, Runcorn	Half Hourly	HS2 CC	200m	
HS2	HS08a	London Euston (HS2)	Liverpool	Runcorn WCML and HS2	Old Oak Common, Crewe, Runcorn		HS2 CC	200m	
HS2	HS08b	London Euston (HS2)	Preston / Lancaster	HS2, Crewe, West Coast	Old Oak Common, Birmingham Interchange, Warrington Bank Quay, Wigan North West, Preston		HS2 CC	200m	
HS2	HS10	London Euston (HS2)	Glasgow Central	WCML	Old Oak Common, Birmingham Interchange, Preston	Hourly	HS2 CC	200m	
HS2	HS09	London Euston (HS2)	Macclesfield	Handsacre, Stafford, Stoke	Old Oak Common, Birmingham Interchange, Preston	Hourly	HS2 CC	200m	
Euston Long Distance	LD01a	London Euston	Shrewsbury	Weedon, West Midlands	Watford Junction, Hemel Hempstead, Milton Keynes Central, Coventry, Birmingham International, Birmingham New Street, Sandwell and Dudley, Wolverhampton, Telford	Half Hourly (to/from BHM)		805	5 Car
Euston Long Distance	LD01b	London Euston	Walsall		Watford Junction, Hemel Hempstead, Milton Keynes Central, Coventry, Birmingham International, Birmingham New Street			805	5 Car
Euston Long Distance	LD02	London Euston	Glasgow Central	Weedon, West Midlands, Crewe	Watford Junction, Leighton Buzzard, Milton Keynes Central, Coventry, Birmingham International, Birmingham New Street, Wolverhampton, Crewe, Warrington Bank Quay				807
Euston Long Distance	LD03	London Euston	Liverpool Lime Street	Northampton, Trent Valley, Crewe	Watford Junction, Milton Keynes Central, Northampton, Rugby Parkway, Rugby, Stafford, Crewe, Runcorn, Liverpool South Parkway	Half Hourly		807	7 Car
Euston Long Distance	LD04	London Euston	Manchester Piccadilly	Northampton, Trent Valley, Stoke	Watford Junction, Milton Keynes Central, Northampton, Long Buckby, Rugby, Stoke-on-Trent, Macclesfield, Stockport				807
Birmingham Interregion	LD05	Birmingham New Street	Liverpool Lime Street	Crewe	Wolverhampton, Stafford, Crewe, Runcorn, Liverpool South Parkway	Hourly		350-110	8 Car
Birmingham Interregion	LD06	Birmingham New Street	Shrewsbury		Smethwick Galton Bridge, Wolverhampton, Telford Central, Wellington	Half Hourly with LD01a		805	5 Car
Euston Long Distance	LD07	London Euston	Manchester Piccadilly	Weedon, Coventry, Trent Valley, Stoke	Milton Keynes Central, Coventry, Nuneaton, Tamworth, Lichfield Trent Valley, Stoke-on-Trent, Stockport	Half Hourly		807	7 Car
Euston Long Distance	LD08	London Euston	Liverpool Lime Street	Weedon, Coventry, Trent Valley	Watford Junction, Coventry, Nuneaton, Tamworth, Lichfield Trent Valley, Crewe, Runcorn, Liverpool South Parkway				807

Euston Long Distance	LD09	London Euston	Chester	Weedon, Trent Valley, Crewe	Hemel Hempstead, Milton Keynes Central, Stafford, Crewe	Half Hourly	805	10 Car	
Euston Long Distance	LD10	London Euston	Crewe	Weedon, Trent Valley, Crewe	Leighton Buzzard, Milton Keynes, Central, Tamworth, Stafford		805	10 Car	
Euston Long Distance	LD11	London Euston	Crewe	Weedon, Trent Valley, Crewe	Bletchley, Milton Keynes Central, Wolverton, Rugby, Nuneaton, Atherstone, Polesworth, Tamworth, Lichfield Trent Valley, Rugeley, Stafford	Half Hourly (Nuneaton to Rugeley)	350-110	8 Car	
West Midlands	WM07	Coventry	Stoke-on-Trent	Trent Valley, Stoke	Coventry Arena, Bedworth, Bermuda Park, Nuneaton, Atherstone, Polesworth, Tamworth, Lichfield Trent Valley, Rugeley, Stoke South		350-110	8Car	
Euston Suburban	SU01	London Euston	Milton Keynes Central		Watford Junction, Hemel Hempstead, Berkhamsted, Leighton Buzzard, Bletchley	Half Hourly	350-110	12 Car	
Euston Suburban	SU02	London Euston	Milton Keynes Central		Watford Junction, Hemel Hempstead, Berkhamsted, Leighton Buzzard, Bletchley		350-110	12 Car	
Euston Suburban	SU03	London Euston	Milton Keynes Central		Watford Junction, Kings Langley, Apsley, Hemel Hempstead, Berkhamsted, Tring, Cheddington, Leighton Buzzard, Bletchley	Half Hourly	350-110	12 Car	
Euston Suburban	SU04	London Euston	Milton Keynes Central		Watford Junction, Kings Langley, Apsley, Hemel Hempstead, Berkhamsted, Tring, Cheddington, Leighton Buzzard, Bletchley		350-110	12 Car	
Euston Suburban	SU05	London Euston	Tring		Wembley Central, Harrow and Wealdstone, Bushey, Watford Junction, Kings Langley, Apsley, Hemel Hempstead, Berkhamsted	Half Hourly	350-110	12 Car	
Euston Suburban	SU06	London Euston	Tring		Wembley Central, Harrow and Wealdstone, Bushey, Watford Junction, Kings Langley, Apsley, Hemel Hempstead, Berkhamsted		350-110	12 Car	
East West Rail	EW01	Oxford	Northampton		Bletchley, Milton Keynes Central, Wolverton	Half Hourly	350-110	4 Car	
East West Rail	EW02	Oxford	Northampton		Bletchley, Milton Keynes Central, Wolverton		350-110	4 Car	
East West Rail	EW03	Aylesbury	Milton Keynes Central		Bletchley	Half Hourly	350-110	4 Car	
East West Rail	EW04	Aylesbury	Milton Keynes Central		Bletchley		350-110	4 Car	
East West Rail	EW05	Cambridge	Birmingham New Street		Bedford, Milton Keynes Central, Northampton, Rugby, Coventry, Birmingham International	Half Hourly	350-110	4 Car	
East West Rail	EW06	Cambridge	Birmingham New Street		Bedford, Milton Keynes Central, Northampton, Rugby, Coventry, Birmingham International		350-110	4 Car	
West London Line	WL01	East Croydon	Milton Keynes Central		Wembley Central, Harrow and Wealdstone, Bushey, Watford Junction, Hemel Hempstead, Berkhamsted, Tring, Leighton Buzzard, Bletchley	Half Hourly	377	8	
West London Line	WL02	East Croydon	Milton Keynes Central		Wembley Central, Harrow and Wealdstone, Bushey, Watford Junction, Hemel Hempstead, Berkhamsted, Tring, Leighton Buzzard, Bletchley		377	8	
Cross Country	XC01	Reading	Manchester Piccadilly	Coventry, West Midlands, Norton Bridge, Stoke	Leamington Spa, Coventry, Birmingham International, Birmingham New Street, Sandwell and Dudley, Wolverhampton, Stafford, Stoke-on-Trent, Congleton, Macclesfield, Stockport	Half Hourly (from Birmingham New Street)	220-110	8	
Cross Country	XC02	Bristol Temple Meads	Manchester Piccadilly	West Midlands, Norton Bridge, Stoke	Cheltenham, Birmingham New Street, Smethwick Galton Bridge, Wolverhampton, Stafford, Stoke-on-Trent, Congleton, Macclesfield, Stockport		220-110	8	

Cross Country	XC03	Reading	Newcastle	Coventry, West Midlands	Leamington Spa, Coventry, Birmingham International, Birmingham New Street	Half Hourly with XC01 (Coventry to Birmingham)	220-110	8		
West Midlands	WM01	Coventry	Wolverhampton	West Midlands	Tile Hill, Hampten in Arden, Birmingham International, Marston Green, Lea Hall, Stechford, Adderly Park, Birmingham New Street, Smethwick Rolfe Street, Smethwick Galton Bridge, Sandwell and Dudley, Dudley Port, Coseley	Half Hourly	350-110	8		
West Midlands	WM02	Coventry	Wolverhampton	West Midlands	Tile Hill, Berkswell, Hampten in Arden, Birmingham International, Marston Green, Lea Hall, Stechford, Birmingham New Street, Smethwick Rolfe Street, Smethwick Galton Bridge, Sandwell and Dudley, Dudley Port, Coseley	Half Hourly	350-110	8		
West Midlands	WM03	Northampton	Wolverhampton	Coventry, West Midlands	Long Buckby, Rugby Parkway, Rugby, Coventry East, Coventry, Canley, Tile Hill, Berkswell, Birmingham International, Martston Green, Birmingham New Street, Smethwick Rolfe Street, Smethwick Galton Bridge, Sandwell and Dudley, Dudley Port, Tipton, Coseley	Half Hourly	350-110	8		
West Midlands	WM04	Northampton	Wolverhampton	Coventry, West Midlands	Long Buckby, Rugby Parkway, Rugby, Coventry East, Coventry, Canley, Tile Hill, Birmingham International, Martston Green, Adderly Park, Birmingham New Street, Smethwick Rolfe Street, Smethwick Galton Bridge, Sandwell and Dudley, Dudley Port, Tipton, Coseley	Half Hourly	350-110	8		
West Midlands	WM05	Birmingham New Street	Stafford	Chase Line	Tame Bridge Parkway, Walsall, Bloxwich, Bloxwich North, Ladywood, Cannock, Hednesford, Rugeley Town, Rugeley Trent Valley	Half Hourly (Birmingham to Rugeley)	350-110	4		
West Midlands	WM06	Birmingham New Street	Stoke-on-Trent	Chase Line, Stoke	Tame Bridge Parkway, Walsall, Bloxwich, Bloxwich North, Ladywood, Cannock, Hednesford, Rugeley Town, Rugeley Trent Valley, Stoke South	Half Hourly	350-110	4		
Crewe Terminators	CR01	Derby	Crewe	North Staffs Line, Stoke, Alsager	Blythe Bridge, Stoke-on-Trent, Longport, Kidsgrove, Alsager	Hourly	170	2		
Crewe Terminators	CR02	Birmingham New Street	Crewe	Norton Bridge, Stoke, Alsager	Tame Bridge Parkway, Darlaston, Willenhall, Wolverhampton, Penkridge, Stafford, Stone, Stoke South, Kidsgrove, Alsager	Half Hourly	350-110	4		
Crewe Terminators	CR03	Birmingham New Street	Stoke-on-Trent	Norton Bridge, Stoke	Tame Bridge Parkway, Darlaston, Willenhall, Wolverhampton, Penkridge, Stafford, Stone, Stoke South	Half Hourly	350-110	4		
Northern	N01	Stoke	Manchester Piccadilly	Cheadle Hulme	Longport, Kidsgrove, Congleton, Macclesfield, Prestbury, Adlington, Poynton, Bramhall, Cheadle Hulme, Stockport	Hourly	323	3		
Freight	FR01	Camden Junction	Birmingham Terminals		via Northampton and Nuneaton	Hourly	90	775m / 1800t	Class 4	
Freight	FR02a	Wembley Central	Birmingham Terminals		via Northampton and Nuneaton	Hourly	90	775m / 1800t	Class 4	
Freight	FR02b	Wembley Central	Daventry		via Northampton	Hourly	90	775m / 1800t	Class 4	
Freight	FR03	Wembley Central	Crewe		via Northampton, Trent Valley and Stafford	Hourly	90	775m / 1800t	Class 4	

Freight	FR04	Camden Junction	Crewe		via Northampton, Trent Valley and Stafford	Hourly	90	775m / 1800t	Class 4
Freight	FR05a	Wembley Central	Birmingham Terminals		via Northampton and Nuneaton	Hourly	90	450m / 2600t	Class 6
Freight	FR05b	Wembley Central	Stone		via Northampton and Hixon	Hourly	90	450m / 2600t	Class 6
Freight	FR05c	Wembley Central	Crewe		via Northampton, Trent Valley and Stafford	Hourly	90	450m / 2600t	Class 6
Freight	FR06a	Wembley Central	Birmingham Terminals		via Northampton (or Weedon) and Nuneaton	Hourly	325	250m / 600t	Class 1
Freight	FR06b	Wembley Central	Crewe		via Northampton (or Weedon), Trent Valley and Stafford	Hourly	325	250m / 600t	Class 1
Freight	FR07	Hinckley	Crewe		via Nuneaton, Trent Valley and Stafford	Hourly	90	450m / 2600t	Class 6
Freight	FR08	Hinckley	Crewe		via Nuneaton, Trent Valley and Stafford	Hourly	90	775m / 1800t	Class 4
Freight	FR09	Hinckley	Birmingham Terminals		via Nuneaton	Hourly	90	775m / 1800t	Class 4
Freight	FR10	Hinckley	Birmingham Terminals		via Nuneaton	Hourly	90	775m / 1800t	Class 4
Freight	FR11	Denbigh Hall South Junction	Daventry		via East West Rail, Northampton	Hourly	90	775m / 1800t	Class 4
Freight	FR12a	Daventry	Birmingham Terminals		via Nuneaton	Hourly	90	775m / 1800t	Class 4
Freight	FR12b	Daventry	Crewe		via Trent Valley and Stafford	Hourly	90	775m / 1800t	Class 4
Freight	FR13	Southampton	Crewe		via Coventry, Nuneaton, Trent Valley and Stafford	Hourly	90	775m / 1800t	Class 4
Freight	FR14	Southampton	Crewe		via Birmingham, Bushbury Junction and Stafford	Hourly	90	775m / 1800t	Class 4
Freight	FR15a	Birmingham Terminals	Crewe		via Bushbury Junction and Stafford	Hourly	90	450m / 2600t	Class 6*
Freight	FR15b	Birmingham Terminals	Stone		via Bushbury Junction, Stafford and Norton Bridge	Hourly	90	450m / 2600t	Class 6

East West Connectivity Released Capacity Train Plan – Generalised Journey Time Results

Figures show Generalised Journey Times in minutes between tested locations.

	EUS	WFJ	HML	LBZ	MKC	RUG	NMP	COV	BHM	NUN	TAM	LTV	WVH	SHR	STA	SOT	CRE	LIV	MAN	CBG	BDM	OXF
EUS		66.7	81.7	95.0	83.5	77.1	117.7	112.3	122.9	92.9	108.0	114.3	137.4	192.0	124.0	158.5	152.6	202.8	92.3	122.3	102.0	140.1
WFJ			15.3	33.4	33.6	71.8	61.8	96.4	144.3	87.0	103.6	110.7	122.6	177.8	103.0	138.0	120.9	217.0	177.5	127.0	73.0	92.5
HML				30.5	35.4	75.4	61.6	77.7	132.7	104.0	123.2	131.3	125.7	171.0	112.2	135.1	128.5	191.3	172.2	120.2	66.2	126.3
LBZ					19.2	63.1	47.4	67.1	126.9	83.5	98.2	105.4	133.8	206.5	112.5	138.3	130.3	226.7	173.5	99.2	45.2	97.2
MKC						34.4	28.1	53.1	110.6	50.8	61.1	67.6	97.9	150.4	74.9	110.4	86.7	182.2	147.2	80.0	37.5	44.3
RUG							31.2	27.4	57.2	31.8	48.5	55.7	96.2	156.1	71.3	78.3	90.9	146.1	119.1	156.0	102.0	58.6
NMP								47.1	76.1	69.7	88.8	97.1	127.0	186.2	102.8	98.3	118.1	239.9	139.0	125.7	81.2	96.8
COV									34.1	40.1	59.2	66.7	66.8	121.6	90.2	93.2	102.5	230.1	128.0	168.8	114.8	64.1
BHM										53.0	41.3	56.0	26.9	80.0	48.2	73.7	69.9	119.9	68.4	197.3	172.9	76.2
NUN											27.3	34.6	92.8	157.1	61.0	73.3	81.6	160.3	118.1	173.8	119.8	72.4
TAM												17.1	78.6	144.8	45.6	57.8	65.3	142.6	101.4	188.4	134.4	79.5
LTV													75.6	147.3	38.6	50.8	58.0	133.3	96.0	195.2	141.2	85.8
WVH														60.7	26.7	53.4	45.5	99.7	95.8	237.8	183.8	112.9
SHR															96.0	119.8	68.7	143.4	112.6	333.3	279.3	205.1
STA																35.5	26.6	78.8	81.9	236.2	182.2	122.8
SOT																	48.7	120.4	63.2	251.7	197.7	135.9
CRE																		61.5	99.1	242.9	188.9	114.4
LIV																			60.7	337.5	283.5	224.5
MAN																				279.6	225.6	167.6
CBG																					175.5	269.4
BDM																						219.0
OXF																						

East West Connectivity With Infrastructure Train Plan – Generalised Journey Time Results

Figures show Generalised Journey Times in minutes between tested locations.

	EUS	WFJ	HML	LBZ	MKC	RUG	NMP	COV	BHM	NUN	TAM	LTV	WVH	SHR	STA	SOT	CRE	LIV	MAN	CBG	BDM	OXF	
EUS		66.0	79.9	91.8	97.3	75.5	110.5	112.3	122.9	91.3	106.5	112.5	137.4	192.0	124.0	152.7	152.6	203.0	92.3	122.3	102.0	140.1	
WFJ			14.2	29.8	33.1	71.5	59.6	92.8	144.1	86.2	103.1	110.3	122.6	177.8	103.0	137.6	120.8	211.4	177.5	127.0	73.0	92.5	
HML				28.6	31.1	72.6	57.3	76.3	135.2	100.1	119.2	127.4	125.1	170.8	101.8	134.2	121.1	191.2	172.3	120.2	66.2	126.3	
LBZ					16.0	59.2	43.4	59.9	121.2	76.1	93.0	100.0	129.7	204.4	111.8	133.4	126.3	187.5	172.3	99.2	45.2	97.2	
MKC						32.1	26.1	50.4	109.7	47.6	60.0	66.5	97.9	150.3	74.9	105.6	86.6	174.1	147.2	80.0	37.5	44.3	
RUG							30.1	24.9	51.4	28.6	45.7	52.8	94.0	154.0	70.8	76.0	90.8	144.9	119.0	156.0	102.0	58.6	
NMP								46.8	75.0	66.7	86.7	94.9	126.6	186.0	102.8	98.2	118.0	236.1	139.0	125.7	81.2	96.8	
COV									33.6	37.8	57.0	63.7	66.5	121.6	89.6	92.9	99.4	197.3	127.9	168.8	114.8	64.1	
BHM										53.0	41.3	55.3	26.9	80.0	48.2	73.4	69.9	119.6	68.4	197.3	172.9	76.2	
NUN											25.2	32.2	92.5	156.8	60.2	67.5	78.8	127.7	117.8	173.8	119.8	72.4	
TAM												15.5	78.0	144.5	44.6	53.4	61.5	101.9	101.3	188.4	134.4	79.5	
LTV													75.0	146.8	37.5	46.1	52.9	92.5	96.0	195.2	141.2	85.8	
WVH														60.7	26.7	53.4	45.5	99.3	95.8	237.8	183.8	112.9	
SHR															96.0	119.8	68.7	142.4	112.6	333.3	279.3	205.1	
STA																35.5	26.6	78.7	81.9	236.2	182.2	122.8	
SOT																	48.7	118.0	63.2	251.7	197.7	135.9	
CRE																		57.5	99.1	242.9	188.9	114.4	
LIV																				60.7	337.5	283.5	224.5
MAN																					279.6	225.6	167.6
CBG																						175.5	269.4
BDM																							219.0
OXF																							

Appendix F – New Connections ITSS and Generalised Journey Times

Base ITSS

Service Type	Code	From	To	Route	Calling Pattern	Pattern	Rolling stock	Length	Class
HS2	HS01	London Euston (HS2)	Birmingham Curzon Street	HS2	Old Oak Common, Birmingham Interchange	20-Minute Pattern	HS2 CC	400m	
HS2	HS02	London Euston (HS2)	Birmingham Curzon Street	HS2	Old Oak Common, Birmingham Interchange		HS2 CC	400m	
HS2	HS03	London Euston (HS2)	Birmingham Curzon Street	HS2	Old Oak Common, Birmingham Interchange	20-Minute Pattern	HS2 CC	400m	
HS2	HS04	London Euston (HS2)	Manchester Piccadilly	HS2, Crewe, Wilmslow	Old Oak Common, Wilmslow, Stockport		HS2 CC	200m	
HS2	HS05	London Euston (HS2)	Manchester Piccadilly	HS2, Crewe, Wilmslow	Old Oak Common, Crewe, Stockport,		HS2 CC	200m	
HS2	HS06	London Euston (HS2)	Manchester Piccadilly	HS2, Crewe, Wilmslow	Old Oak Common, Stockport		HS2 CC	200m	
HS2	HS07	London Euston (HS2)	Liverpool	Runcorn WCML and HS2	Old Oak Common, Crewe, Runcorn		HS2 CC	200m	
HS2	HS08a	London Euston (HS2)	Liverpool	Runcorn WCML and HS2	Old Oak Common, Crewe, Runcorn	Half Hourly	HS2 CC	200m	
HS2	HS08b	London Euston (HS2)	Preston / Lancaster	HS2, Crewe, West Coast	Old Oak Common, Birmingham Interchange, Warrington Bank Quay, Wigan North West, Preston		HS2 CC	200m	
HS2	HS10	London Euston (HS2)	Glasgow Central	WCML	Old Oak Common, Birmingham Interchange, Preston	Hourly	HS2 CC	200m	
HS2	HS09	London Euston (HS2)	Macclesfield	Handsacre, Stafford, Stoke	OOC, Stafford, Stoke	Hourly	HS2 CC	200m	
Euston Long Distance	LD01a	London Euston	Shrewsbury	Weedon, West Midlands	Watford Junction, Hemel Hempstead, Milton Keynes Central, Daventry Parkway , Coventry, Birmingham International, Birmingham New Street, Sandwell and Dudley,	Half Hourly (to/from BHM)	805	5 Car	
Euston Long Distance	LD01b	London Euston	Walsall		Watford Junction, Hemel Hempstead, Milton Keynes Central, Coventry, Birmingham International, Birmingham New Street		805	5 Car	
Euston Long Distance	LD02	London Euston	Glasgow Central	Weedon, West Midlands, Crewe	Watford Junction, Leighton Buzzard, Milton Keynes Central, Daventry Parkway , Coventry, Birmingham International, Birmingham New Street, Wolverhampton, Crewe, Warrington Bank Quay		807	7 Car	
Euston Long Distance	LD03	London Euston	Liverpool Lime Street	Northampton, Trent Valley, Crewe	Watford Junction, Milton Keynes Central, South Northampton , Northampton, Rugby, Stafford, Crewe, Runcorn, Liverpool South Parkway	Half Hourly	807	7 Car	
Euston Long Distance	LD04	London Euston	Manchester Piccadilly	Northampton, Trent Valley, Stoke	Watford Junction, Milton Keynes Central, South Northampton , Northampton, Rugby, Stoke-on-Trent, Macclesfield, Stockport		807	7 Car	
Birmingham Interregional	LD05	Birmingham New Street	Liverpool Lime Street	Crewe	Wolverhampton, Stafford, Crewe, Runcorn, Liverpool South Parkway	Hourly	350-110	8 Car	
Birmingham Interregional	LD06	Birmingham New Street	Shrewsbury		Smethwick Galton Bridge, Wolverhampton, Telford Central, Wellington	Half Hourly with LD01a	805	5 Car	
Euston Long Distance	LD07	London Euston	Manchester Piccadilly	Weedon, Coventry, Trent Valley, Stoke	Milton Keynes Central, Coventry East , Coventry, Nuneaton, Tamworth, Lichfield Trent Valley, Stoke-on-Trent, Stockport	Half Hourly	807	7 Car	
Euston Long Distance	LD08	London Euston	Liverpool Lime Street	Weedon, Coventry, Trent Valley, Stoke	Watford Junction, Coventry East , Coventry, Nuneaton, Tamworth, Lichfield Trent Valley, Crewe, Runcorn, Liverpool South Parkway		807	7 Car	
Euston Long Distance	LD09	London Euston	Chester	Weedon, Trent Valley, Crewe	Hemel Hempstead, Milton Keynes Central, Stafford, Crewe	Half Hourly	805	10 Car	
Euston Long Distance	LD10	London Euston	Crewe	Weedon, Trent Valley, Crewe	Leighton Buzzard, Milton Keynes Central, Wolverton, Tamworth, Stafford		805	10 Car	

East London Long Distance	LD11	London Euston	Crewe	Weedon, Trent Valley, Crewe	Bletchley, Milton Keynes Central, Rugby Parkway , Rugby, Nuneaton, Atherstone, Polesworth, Tamworth, Lichfield Trent Valley, Rugeley, Stafford, Meecebrook	Half Hourly (Nuneaton to Rugeley)	350-110	8 Car	
West Midlands	WM09	Coventry	Stoke-on-Trent	Trent Valley, Stoke	Coventry Arena, Bedworth, Bermuda Park, Nuneaton, Atherstone, Polesworth, Tamworth, Lichfield Trent Valley, Rugeley, Stoke South		350-110	8 Car	
Euston Suburban	SU01	London Euston	Milton Keynes Central		Watford Junction, Hemel Hempstead, Berkhamsted, Leighton Buzzard, Bletchley	Half Hourly	350-110	8 Car	
Euston Suburban	SU02	London Euston	Milton Keynes Central		Watford Junction, Hemel Hempstead, Berkhamsted, Leighton Buzzard, Bletchley		350-110	8 Car	
Euston Suburban	SU03	London Euston	Milton Keynes Central		Watford Junction, Kings Langley, Apsley, Hemel Hempstead, Berkhamsted, Tring, Cheddington, Leighton Buzzard, Bletchley	Half Hourly	350-110	12 Car	
Euston Suburban	SU04	London Euston	Milton Keynes Central		Watford Junction, Kings Langley, Apsley, Hemel Hempstead, Berkhamsted, Tring, Cheddington, Leighton Buzzard, Bletchley		350-110	12 Car	
Euston Suburban	SU05	London Euston	Tring		Wembley Central, Harrow and Wealdstone, Bushey, Watford Junction, Kings Langley, Apsley, Hemel Hempstead, Berkhamsted	Half Hourly	350-110	12 Car	
Euston Suburban	SU06	London Euston	Tring		Wembley Central, Harrow and Wealdstone, Bushey, Watford Junction, Kings Langley, Apsley, Hemel Hempstead, Berkhamsted		350-110	12 Car	
East West Rail	EW01	Oxford	Northampton		Bletchley, Milton Keynes Central, Wolverton	Half Hourly	350-110	4 Car	
East West Rail	EW02	Oxford	Northampton		Bletchley, Milton Keynes Central, Wolverton		350-110	4 Car	
East West Rail	EW03	Aylesbury	Milton Keynes Central		Bletchley	Half Hourly	350-110	4 Car	
East West Rail	EW04	Aylesbury	Milton Keynes Central		Bletchley		350-110	4 Car	
East West Rail	EW05	Cambridge	Milton Keynes Central		Bedford	Half Hourly	350-110	4 Car	
East West Rail	EW06	Cambridge	Milton Keynes Central		Bedford		350-110	4 Car	
West London Line	WL01	East Croydon	Milton Keynes Central		Wembley Central, Harrow and Wealdstone, Bushey, Watford Junction, Hemel Hempstead, Berkhamsted, Tring, Leighton Buzzard, Bletchley	Half Hourly	377	8	
West London Line	WL02	East Croydon	Milton Keynes Central		Wembley Central, Harrow and Wealdstone, Bushey, Watford Junction, Hemel Hempstead, Berkhamsted, Tring, Leighton Buzzard, Bletchley		377	8	
Cross Country	XC01	Reading	Manchester Piccadilly	Coventry, West Midlands, Norton Bridge, Stoke	Leamington Spa, Coventry, Birmingham International, Birmingham New Street, Sandwell and Dudley, Wolverhampton, Stafford, Stoke-on-Trent, Congleton, Macclesfield, Stockport	Half Hourly (from Birmingham New Street)	220-110	8	
Cross Country	XC02	Bristol Temple Meads	Manchester Piccadilly	West Midlands, Norton Bridge, Stoke	Cheltenham, Birmingham New Street, Smethwick Galton Bridge, Wolverhampton, Stafford, Stoke-on-Trent, Congleton, Macclesfield, Stockport		220-110	8	
Cross Country	XC03	Reading	Newcastle	Coventry, West Midlands	Leamington Spa, Coventry, Birmingham International, Birmingham New Street	Half Hourly with XC01 (Coventry to Birmingham)	220-110	8	
West Midlands	WM01	Coventry	Wolverhampton	West Midlands	Tile Hill, Hampton in Arden, Birmingham International, Marston Green, Lea Hall, Stechford, Adderly Park, Birmingham New Street, Smethwick Rolfe Street, Smethwick Galton Bridge, Sandwell and Dudley, Dudley Port, Coseley	Half Hourly	350-110	8	
West Midlands	WM02	Coventry	Wolverhampton	West Midlands	Tile Hill, Berkswell, Hampton in Arden, Birmingham International, Marston Green, Lea Hall, Stechford, Birmingham New Street, Smethwick Rolfe Street, Smethwick Galton Bridge, Sandwell and Dudley, Dudley Port, Coseley		350-110	8	

West Midlands	WM03	Northampton	Wolverhampton	Coventry, West Midlands	Long Buckby, Rugby Parkway, Rugby, Coventry East, Coventry, Canley, Tile Hill, Berkswell, Birmingham International, Martston Green, Birmingham New Street, Smethwick Rolfe Street, Smethwick Galton Bridge, Sandwell and Dudley, Dudley Port, Tipton, Coseley	Half Hourly	350-110	8		
West Midlands	WM04	Northampton	Wolverhampton	Coventry, West Midlands	Long Buckby, Rugby Parkway, Rugby, Coventry East, Coventry, Canley, Tile Hill, Birmingham International, Martston Green, Adderly Park, Birmingham New Street, Smethwick Rolfe Street, Smethwick Galton Bridge, Sandwell and Dudley, Dudley Port, Tipton, Coseley		350-110	8		
West Midlands	WM05	Birmingham New Street	Crewe	Chase Line	Tame Bridge Parkway, Walsall, Blaxwich, Blaxwich North, Ladywood, Cannock, Hednesford, Rugeley Town, Rugeley Trent Valley, Stafford, Meecebrook	Half Hourly (Birmingham to Rugeley)	350-110	4		
West Midlands	WM06	Birmingham New Street	Stoke-on-Trent	Chase Line, Stoke	Tame Bridge Parkway, Walsall, Blaxwich, Blaxwich North, Ladywood, Cannock, Hednesford, Rugeley Town, Rugeley Trent Valley, Stoke South		350-110	4		
West Midlands	WM07	Northampton	Birmingham New Street		Rugby, Coventry, Birmingham International	Half Hourly	350-110	8		
West Midlands	WM08	Northampton	Birmingham New Street		Rugby, Coventry, Birmingham International		350-110	8		
Crewe Terminators	CR01	Derby	Crewe	North Staffs Line, Stoke, Alsager	Blythe Bridge, Stoke-on-Trent, Longport, Kidsgrove, Alsager	Hourly		170	2	
Crewe Terminators	CR02	Birmingham New Street	Crewe	Norton Bridge, Stoke, Alsager	Tame Bridge Parkway, Darlaston, Willenhall, Wolverhampton, Brinsford, Penkridge, Stafford, Stone, Stoke South, Kidsgrove, Alsager	Half Hourly	350-110	4		
Crewe Terminators	CR03	Birmingham New Street	Stoke-on-Trent	Norton Bridge, Stoke	Tame Bridge Parkway, Darlaston, Willenhall, Wolverhampton, Brinsford, Penkridge, Stafford, Stone, Stoke South		350-110	4		
Northern	N01	Stoke	Manchester Piccadilly	Cheadle Hulme	Longport, Kidsgrove, Congleton, Macclesfield, Prestbury, Adlington, Poynton, Bramhall, Cheadle Hulme, Stockport	Hourly		323	3	
Freight	FR01	Camden Junction	Birmingham Terminals		via Northampton and Nuneaton	Hourly	90	775m / 1800t	Class 4	
Freight	FR02a	Wembley Central	Birmingham Terminals		via Northampton and Nuneaton	Hourly	90	775m / 1800t	Class 4	
Freight	FR02b	Wembley Central	Daventry		via Northampton	Hourly	90	775m / 1800t	Class 4	
Freight	FR03	Wembley Central	Crewe		via Northampton, Trent Valley and Stafford	Hourly	90	775m / 1800t	Class 4	
Freight	FR04	Camden Junction	Crewe		via Northampton, Trent Valley and Stafford	Hourly	90	775m / 1800t	Class 4	
Freight	FR05a	Wembley Central	Birmingham Terminals		via Northampton and Nuneaton	Hourly	90	450m / 2600t	Class 6	
Freight	FR05b	Wembley Central	Stone		via Northampton and Hixon	Hourly	90	450m / 2600t	Class 6	
Freight	FR05c	Wembley Central	Crewe		via Northampton, Trent Valley and Stafford	Hourly	90	450m / 2600t	Class 6	
Freight	FR06a	Wembley Central	Birmingham Terminals		via Northampton (or Weedon) and Nuneaton	Hourly	325	250m / 600t	Class 1	
Freight	FR06b	Wembley Central	Crewe		via Northampton (or Weedon), Trent Valley and Stafford	Hourly	325	250m / 600t	Class 1	
Freight	FR07	Hinckley	Crewe		via Nuneaton, Trent Valley and Stafford	Hourly	90	450m / 2600t	Class 6	
Freight	FR08	Hinckley	Crewe		via Nuneaton, Trent Valley and Stafford	Hourly	90	775m / 1800t	Class 4	
Freight	FR09	Hinckley	Birmingham Terminals		via Nuneaton	Hourly	90	775m / 1800t	Class 4	
Freight	FR10	Hinckley	Birmingham Terminals		via Nuneaton	Hourly	90	775m / 1800t	Class 4	
Freight	FR11	Denbigh Hall South Junction	Daventry		via East West Rail, Northampton	Hourly	90	775m / 1800t	Class 4	
Freight	FR12a	Daventry	Birmingham Terminals		via Nuneaton	Hourly	90	775m / 1800t	Class 4	
Freight	FR12b	Daventry	Crewe		via Trent Valley and Stafford	Hourly	90	775m / 1800t	Class 4	
Freight	FR13	Southampton	Crewe		via Coventry, Nuneaton, Trent Valley and Stafford	Hourly	90	775m / 1800t	Class 4	
Freight	FR14	Southampton	Crewe		via Birmingham, Bushbury Junction and Stafford	Hourly	90	775m / 1800t	Class 4	
Freight	FR15a	Birmingham Terminals	Crewe		via Bushbury Junction and Stafford	Hourly	90	450m / 2600t	Class 6*	
Freight	FR15b	Birmingham Terminals	Stone		via Bushbury Junction, Stafford and Norton Bridge	Hourly	90	450m / 2600t	Class 6	

New Connections Released Capacity Train Plan – Generalised Journey Time Results

Figures show Generalised Journey Times in minutes between tested locations.

	EUS	WFJ	HML	LBZ	MKC	RUG	NMP	COV	BHM	NUN	TAM	LTV	WVH	SHR	STA	SOT	CRE	LIV	MAN	CBG	BDM	OXF
EUS		67.7	80.8	91.5	98.3	78.1	108.5	112.3	122.9	93.6	108.0	113.9	137.5	192.0	161.6	154.2	150.9	187.3	92.3	122.3	102.0	140.1
WFJ			17.4	30.6	32.8	67.0	58.0	94.6	140.8	85.2	99.8	106.5	122.4	177.4	125.7	135.8	140.4	237.0	173.1	310.5	139.9	93.4
HML				34.4	31.0	65.8	52.4	70.5	119.1	101.7	119.3	127.7	123.5	169.9	103.3	161.0	123.3	212.5	186.1	320.5	134.1	127.1
LBZ					18.0	62.5	45.3	58.6	125.0	76.3	90.8	97.3	131.8	205.5	115.8	122.1	132.9	226.9	157.5	309.6	107.8	98.0
MKC						33.3	26.0	49.4	105.7	49.9	60.6	67.1	97.3	149.7	83.1	107.8	92.8	203.3	147.4	256.2	104.5	45.2
RUG							30.3	22.4	41.0	33.6	48.4	55.6	87.1	149.0	78.6	89.5	101.8	180.4	134.9	252.2	168.5	59.4
NMP								45.0	57.5	71.4	89.4	97.8	112.0	172.9	119.5	137.4	141.6	338.8	171.8	308.4	133.5	97.7
COV									31.0	38.6	54.8	61.6	65.5	121.2	90.8	83.5	102.3	231.4	125.7	260.9	182.8	64.1
BHM										52.9	41.3	54.3	26.9	80.0	48.3	73.0	70.1	120.4	69.1	214.9	189.1	77.1
NUN											25.8	32.9	93.3	157.1	66.1	64.0	87.4	164.1	105.1	191.5	159.4	73.3
TAM												17.6	80.1	146.3	51.2	50.6	72.2	145.0	91.3	266.5	205.7	80.3
LTV													80.6	151.8	44.6	43.5	65.0	135.5	86.7	275.2	237.4	86.6
WVH														60.8	26.7	53.4	45.6	100.0	95.8	281.4	265.9	113.7
SHR															96.3	119.9	68.7	143.5	112.6	346.8	341.6	205.9
STA																35.5	32.9	80.5	81.8	295.3	262.1	123.6
SOT																	49.0	123.3	60.2	257.1	258.5	136.7
CRE																		63.0	99.1	313.9	280.5	115.2
LIV																			60.7	389.8	361.6	225.3
MAN																				296.5	297.0	168.4
CBG																					210.5	389.1
BDM																						262.4
OXF																						

New Connections With Infrastructure Train Plan – Generalised Journey Time Results

Figures show Generalised Journey Times in minutes between tested locations.

	EUS	WFJ	HML	LBZ	MKC	RUG	NMP	COV	BHM	NUN	TAM	LTV	WVH	SHR	STA	SOT	CRE	LIV	MAN	CBG	BDM	OXF	
EUS		68.5	79.7	91.5	83.3	78.2	110.7	109.9	124.2	93.5	107.9	113.8	137.5	192.0	123.9	152.1	147.9	193.5	92.3	122.3	102.0	140.1	
WFJ			15.1	30.4	33.1	71.1	61.0	95.1	144.7	85.2	99.8	106.5	122.7	177.8	119.6	135.7	134.2	215.7	172.9	137.0	83.0	92.5	
HML				32.8	31.6	75.0	59.2	76.0	156.2	103.7	121.2	129.4	124.9	170.8	100.1	159.4	117.9	174.3	184.9	130.2	76.2	126.3	
LBZ					18.0	62.6	46.0	58.6	125.5	76.3	90.8	97.3	131.8	205.5	115.3	122.0	132.8	218.8	157.5	109.2	55.2	97.2	
MKC						33.1	28.2	51.2	109.7	49.4	60.4	66.9	98.0	150.1	80.7	106.0	92.1	179.6	142.2	90.0	47.5	44.3	
RUG							29.8	22.4	41.0	33.2	48.0	55.2	87.0	149.0	68.1	88.9	88.7	128.8	134.9	166.0	112.0	58.6	
NMP								45.0	52.5	71.1	89.2	97.5	111.2	173.0	90.2	135.1	105.5	164.6	171.8	123.7	83.2	89.8	
COV									31.0	38.4	54.7	61.5	65.5	121.2	89.7	83.5	102.0	229.3	125.7	178.8	124.8	64.1	
BHM										53.0	41.3	54.3	26.9	80.0	48.3	73.0	70.1	120.4	69.1	207.3	182.9	76.2	
NUN											25.4	32.5	93.1	157.0	65.6	63.9	0.0	161.8	105.1	183.8	129.8	72.4	
TAM												17.1	80.2	145.6	50.7	50.3	71.7	143.7	91.3	198.4	144.4	79.5	
LTV													80.3	150.5	44.0	43.2	64.5	134.1	86.7	205.2	151.2	85.8	
WVH														60.8	26.7	53.4	45.6	99.9	95.8	247.8	193.8	112.9	
SHR															96.2	121.4	68.7	143.3	112.6	343.3	289.3	205.1	
STA																35.5	31.4	79.5	81.8	246.2	192.2	122.8	
SOT																	49.0	119.6	59.0	261.7	207.7	135.9	
CRE																		60.2	99.1	252.9	198.9	114.4	
LIV																				60.7	347.5	293.5	224.5
MAN																					289.6	235.6	167.6
CBG																						175.5	269.4
BDM																							219.0
OXF																							

Appendix G – Peak Commuter ITSS

Base ITSS

Service Type	Code	From	To	Route	Calling Pattern	Pattern	Rolling stock	Length (Car)	Class
HS2	HS01	London Euston (HS2)	Birmingham Curzon Street	HS2	Old Oak Common, Birmingham Interchange	20-Minute Pattern	HS2 CC	400m	
HS2	HS02	London Euston (HS2)	Birmingham Curzon Street	HS2	Old Oak Common, Birmingham Interchange		HS2 CC	400m	
HS2	HS03	London Euston (HS2)	Birmingham Curzon Street	HS2	Old Oak Common, Birmingham Interchange		HS2 CC	400m	
HS2	HS04	London Euston (HS2)	Manchester Piccadilly	HS2, Crewe, Wilmslow	Old Oak Common, Wilmslow, Stockport	20-Minute Pattern	HS2 CC	200m	
HS2	HS05	London Euston (HS2)	Manchester Piccadilly	HS2, Crewe, Wilmslow	Old Oak Common, Crewe, Stockport,		HS2 CC	200m	
HS2	HS06	London Euston (HS2)	Manchester Piccadilly	HS2, Crewe, Wilmslow	Old Oak Common, Stockport		HS2 CC	200m	
HS2	HS07	London Euston (HS2)	Liverpool	Runcorn WCML and HS2	Old Oak Common, Crewe, Runcorn	Half Hourly	HS2 CC	200m	
HS2	HS08a	London Euston (HS2)	Liverpool	Runcorn WCML and HS2	Old Oak Common, Crewe, Runcorn		HS2 CC	200m	
HS2	HS08b	London Euston (HS2)	Preston / Lancaster	HS2, Crewe, West Coast	Old Oak Common, Birmingham Interchange, Warrington Bank Quay, Wigan North West, Preston		HS2 CC	200m	
HS2	HS10	London Euston (HS2)	Glasgow Central	WCML	Old Oak Common, Birmingham Interchange, Preston	Hourly	HS2 CC	200m	
HS2	HS09	London Euston (HS2)	Macclesfield	Handsacre, Stafford, Stoke	OOC, Stafford, Stoke	Hourly	HS2 CC	200m	
Euston Long Distance	LD01	Shrewsbury	London Euston	Weedon, Coventry Corridor	Wellington, Telford, Wolverhampton, Sandwell and Dudley, Birmingham New Street, Birmingham International, Coventry, Milton Keynes Central, Watford Junction	Half Hourly	805	10	
Euston Long Distance	LD02	Glasgow Central	London Euston	Weedon, Coventry Corridor	Preston, Wigan, Warrington Bank Quay, Crewe, Wolverhampton, Birmingham New Street, Birmingham International, Coventry, Milton Keynes Central, Watford Junction		807	7	
Euston Long Distance	LD03	Birmingham New Street	London Euston	Northampton, Coventry Corridor	Birmingham International, Coventry, Rugby, Long Buckby, Northampton, Watford Junction	Half Hourly	807	7	
Euston Long Distance	LD04	Birmingham New Street	London Euston	Northampton, Coventry Corridor	Birmingham International, Coventry, Rugby, Rugby Parkway, Northampton, Watford Junction		807	7	
Birmingham Intercity	LD05	Liverpool Lime Street	Birmingham New Street	Wolverhampton Corridor, Stafford	Liverpool South Parkway, Runcorn, Crewe, Stafford, Wolverhampton	Hourly	350-110	8	
Birmingham Intercity	LD06	Shrewsbury	Birmingham New Street	Wolverhampton Corridor	Wellington, Telford, Wolverhampton, Smethwick Galton Bridge	Half Hourly with LD01	805	10	
Euston Intercity	LD07	Chester	London Euston	Weedon, Trent Valley, Stafford	Crewe, Stafford, Watford Junction	Half Hourly	805	10	
Euston Intercity	LD08	Liverpool Lime Street	London Euston	Weedon, Trent Valley, Stafford	Liverpool South Parkway, Runcorn, Lichfield Trent Valley, Milton Keynes Central		807	7	
Euston Intercity	LD09	Crewe	London Euston	Weedon, Trent Valley, Stafford	Stafford, Tamworth, Leighton Buzzard	<i>Alter calling patterns based on an even interval pattern between Trent Valley</i>	807	7	
Euston Intercity	LD10	Crewe	London Euston	Weedon, Trent Valley, Stafford	Lichfield Trent Valley, Nuneaton, Hemel Hempstead		807	7	
Euston Intercity	LD11	Manchester Piccadilly	London Euston	Weedon, Trent Valley, Hixon, Cheadle Hulme	Stockport, Stoke-on-Trent, Tamworth, Milton Keynes Central	Half Hourly	807	7	
Euston Intercity	LD12	Manchester Piccadilly	London Euston	Weedon, Trent Valley, Hixon, Cheadle Hulme	Stockport, Stoke-on-Trent, Nuneaton, Watford Junction, Central		807	7	

Euston Long Distance	LD13	Crewe	London Euston	Weedon, Trent Valley, Stafford	Stafford, Rugeley Trent Valley, Lichfield Trent Valley, Tamworth, Polesworth, Atherstone, Nuneaton, Rugby, Milton Keynes Central, Watford Junction	Half Hourly	350-110	8	
Euston Long Distance	LD14	Stoke-on-Trent	London Euston	Weedon, Trent Valley, Hixon	Stoke South, Rugeley Trent Valley, Lichfield Trent Valley, Tamworth, Polesworth, Atherstone, Nuneaton, Rugby, Milton Keynes Central, Watford Junction		350-110	8	
Euston Suburban	SU01	Tring	London Euston		Berkhamsted, Hemel Hempstead, Apsley, King's Langley, Watford Junction, Bushey, Harrow and Wealdstone, Wembley Central	Half Hourly	350-110	12	
Euston Suburban	SU02	Tring	London Euston		Berkhamsted, Hemel Hempstead, Apsley, King's Langley, Watford Junction, Bushey, Harrow and Wealdstone, Wembley Central		350-110	12	
Euston Suburban	SU03	Milton Keynes Central	London Euston		Bletchley, Leighton Buzzard, Cheddington, Tring, Berkhamsted, Hemel Hempstead, Apsley, King's Langley, Watford Junction, Harrow and Wealdstone	Half Hourly	350-110	12	
Euston Suburban	SU04	Milton Keynes Central	London Euston		Bletchley, Leighton Buzzard, Cheddington, Tring, Berkhamsted, Hemel Hempstead, Apsley, King's Langley, Watford Junction, Harrow and Wealdstone		350-110	12	
Euston Suburban	SU05	Milton Keynes Central	London Euston		Bletchley, Leighton Buzzard, Berkhamsted, Hemel Hempstead, Apsley, King's Langley, Watford Junction	Half Hourly	350-110	12	
Euston Suburban	SU06	Milton Keynes Central	London Euston		Bletchley, Leighton Buzzard, Berkhamsted, Hemel Hempstead, Apsley, King's Langley, Watford Junction		350-110	12	
Euston Suburban	SU07	Northampton	London Euston		Wolverton, Milton Keynes Central, Berkhamsted, Hemel Hempstead	15 Minute	350-110	8	
Euston Suburban	SU08	Northampton	London Euston		Wolverton, Milton Keynes Central, Leighton Buzzard, Berkhamsted,		350-110	8	
Euston Suburban	SU09	Northampton	London Euston		Wolverton, Milton Keynes Central, Hemel Hempstead, Watford Junction		350-110	8	
Euston Suburban	SU10	Northampton	London Euston		Wolverton, Milton Keynes Central, Leighton Buzzard, Watford Junction		350-110	8	
Euston Suburban	WL01	Milton Keynes Central	Clapham Junction		Bletchley, Leighton Buzzard, Tring, Berkhamsted, Hemel Hempstead, Watford Junction, Bushey, Harrow and Wealdstone	Half Hourly	377	8	
Euston Suburban	WL02	Milton Keynes Central	Clapham Junction		Bletchley, Leighton Buzzard, Tring, Berkhamsted, Hemel Hempstead, Watford Junction, Bushey, Harrow and Wealdstone		377	8	
East West Rail	EW01	Northampton	Oxford	Bletchley HI Level	Wolverton, Milton Keynes Central, Bletchley	Half Hourly	350-110	4	
East West Rail	EW02	Northampton	Oxford	Bletchley HI Level	Wolverton, Milton Keynes Central, Bletchley		350-110	4	
East West Rail	EW03	Milton Keynes Central	Cambridge	Bletchley east chord		Half Hourly	350-110	4	
East West Rail	EW04	Milton Keynes Central	Cambridge	Bletchley east chord			350-110	4	
East West Rail	EW05	Milton Keynes Central	Aylesbury	Bletchley HI Level	Bletchley	Half Hourly	350-110	4	
East West Rail	EW06	Milton Keynes Central	Aylesbury	Bletchley HI Level	Bletchley		350-110	4	

West Midlands	WM01	Wolverhampton	Coventry		Coseley, Tipton, Dudley Port, Smethwick Galton Bridge, Smethwick Rolf Street, Birmingham New Street, Adderly Park, Stechford, Lea Hall, Marston Green, Birmingham International, Hampton in Arden, Tile Hill	Half Hourly	350-110	8	
West Midlands	WM02	Wolverhampton	Coventry		Coseley, Tipton, Dudley Port, Smethwick Galton Bridge, Smethwick Rolf Street, Birmingham New Street, Stechford, Lea Hall, Marston Green, Birmingham International, Hampton in Arden, Berkswell, Tile Hill		350-110	8	
West Midlands	WM03	Wolverhampton	Northampton		Coseley, Tipton, Dudley Port, Smethwick Galton Bridge, Smethwick Rolf Street, Birmingham New Street, Marston Green, Birmingham International, Berkswell, Tile Hill, Canley, Coventry, Coventry East, Rugby, Rugby Parkway, Long Buckby	Half Hourly	350-110	8	
West Midlands	WM04	Wolverhampton	Northampton		Coseley, Tipton, Dudley Port, Smethwick Galton Bridge, Smethwick Rolf Street, Birmingham New Street, Adderly Park, Marston Green, Birmingham International, Tile Hill, Canley, Coventry, Coventry East, Rugby, Rugby Parkway, Long Buckby		350-110	8	
West Midlands	WM05	Stafford	Birmingham New Street	Chase Line	Rugeley Trent Valley, Rugeley Town, Hednesford, Cannock, Ladywood, Bloxwich North, Bloxwich, Walsall, Tame Bridge Parkway	Half Hourly	350-110	4	
West Midlands	WM06	Stoke-on-Trent	Birmingham New Street	Hixon, Chase Line	Stoke South, Rugeley Trent Valley, Rugeley Town, Hednesford, Cannock, Ladywood, Bloxwich North, Bloxwich, Walsall, Tame Bridge Parkway		350-110	4	
CrossCountry	XC01	Manchester Piccadilly	Reading	Norton Bridge	Stockport, Macclesfield, Congleton, Stoke-on-Trent, Stafford, Wolverhampton, Sandwell and Dudley, Birmingham New Street, Birmingham International, Coventry	Half Hourly (from Birmingham New Street)	220-110	8	
CrossCountry	XC02	Manchester Piccadilly	Bristol	Norton Bridge	Stockport, Macclesfield, Congleton, Stoke-on-Trent, Stafford, Wolverhampton, Smethwick Galton Bridge, Birmingham New Street		220-110	8	
CrossCountry	XC03	Newcastle	Reading	Coventry Corridor	Birmingham New Street, Birmingham International, Coventry	Half Hourly with XC01 (Coventry to Birmingham)	220-110	8	
DC Line	DC01	Watford Junction	London Euston	Camden Jn	<i>all stops</i>		710	4	
DC Line	DC02	Watford Junction	London Euston	Camden Jn	<i>all stops</i>		710	4	
DC Line	DC03	Watford Junction	London Euston	Camden Jn	<i>all stops</i>		710	4	
DC Line	DC04	Watford Junction	London Euston	Camden Jn	<i>all stops</i>		710	4	
Crewe Terminators	CR01	Crewe	Derby		Stoke-on-Trent, Longport, Kidsgrove, Alsager	Hourly	170	2	
Crewe Terminators	CR02	Crewe	Birmingham New Street	Norton Bridge	Alsager, Kidsgrove, Stoke-on-Trent, Stoke South, Stone, Stafford, Penkridge, Wolverhampton, Willenhall, Darlaston, Tame Bridge Parkway	Half Hourly	350-110	4	
Crewe Terminators	CR03	Crewe	Birmingham New Street	Norton Bridge	Alsager, Kidsgrove, Stoke-on-Trent, Stoke South, Stone, Stafford, Penkridge, Wolverhampton, Willenhall, Darlaston, Tame Bridge Parkway		350-110	4	

Northern	NT01	Manchester Piccadilly	Stoke-on-Trent		Longport, Kidsgrove, Congleton, Macclesfield, Prestbury, Adlington, Poynton, Bramhall, Cheadle Hulme, Stockport	Hourly	323	3	
Caledonian Sleeper		London Euston	London Euston	Include in the plan per current operations. Occupies Platform 1 for full hour.	London Euston				
Caledonian Sleeper		London Euston	London Euston	Include in the plan per current operations. Occupies Platform 15 for full hour.	London Euston				
Freight	FR01	Camden Junction	Birmingham Terminals		via Northampton and Nuneaton	Hourly	90	775m / 1800t	Class 4
Freight	FR02a	Wembley Central	Birmingham Terminals		via Northampton and Nuneaton	Hourly	90	775m / 1800t	Class 4
Freight	FR02b	Wembley Central	Daventry		via Northampton	Hourly	90	775m / 1800t	Class 4
Freight	FR03	Wembley Central	Crewe		via Northampton, Trent Valley and Stafford	Hourly	90	775m / 1800t	Class 4
Freight	FR04	Camden Junction	Crewe		via Northampton, Trent Valley and Stafford	Hourly	90	775m / 1800t	Class 4
Freight	FR05a	Wembley Central	Birmingham Terminals		via Northampton and Nuneaton	Hourly	90	450m / 2600t	Class 6
Freight	FR05b	Wembley Central	Stone		via Northampton and Hixon	Hourly	90	450m / 2600t	Class 6
Freight	FR05c	Wembley Central	Crewe		via Northampton, Trent Valley and Stafford	Hourly	90	450m / 2600t	Class 6
Freight	FR06a	Wembley Central	Birmingham Terminals		via Northampton (or Weedon) and Nuneaton	Hourly	325	250m / 600t	Class 1
Freight	FR06b	Wembley Central	Crewe		via Northampton (or Weedon), Trent Valley and Stafford	Hourly	325	250m / 600t	Class 1
Freight	FR07	Hinckley	Crewe		via Nuneaton, Trent Valley and Stafford	Hourly	90	450m / 2600t	Class 6
Freight	FR08	Hinckley	Crewe		via Nuneaton, Trent Valley and Stafford	Hourly	90	775m / 1800t	Class 4
Freight	FR09	Hinckley	Birmingham Terminals		via Nuneaton	Hourly	90	775m / 1800t	Class 4
Freight	FR10	Hinckley	Birmingham Terminals		via Nuneaton	Hourly	90	775m / 1800t	Class 4
Freight	FR11	Denbigh Hall South Junction	Daventry		via East West Rail, Northampton	Hourly	90	775m / 1800t	Class 4
Freight	FR12a	Daventry	Birmingham Terminals		via Nuneaton	Hourly	90	775m / 1800t	Class 4
Freight	FR12b	Daventry	Crewe		via Trent Valley and Stafford	Hourly	90	775m / 1800t	Class 4
Freight	FR13	Southampton	Crewe		via Coventry, Nuneaton, Trent Valley and Stafford	Hourly	90	775m / 1800t	Class 4
Freight	FR14	Southampton	Crewe		via Birmingham, Bushbury Junction and Stafford	Hourly	90	775m / 1800t	Class 4
Freight	FR15a	Birmingham Terminals	Crewe		via Bushbury Junction and Stafford	Hourly	90	450m / 2600t	Class 6*
Freight	FR15b	Birmingham Terminals	Stone		via Bushbury Junction, Stafford and Norton Bridge	Hourly	90	450m / 2600t	Class 6

Peak Commuter Released Capacity Train Plan – Generalised Journey Time Results

Figures show Generalised Journey Times in minutes between tested locations.

	EUS	WFJ	HML	LBZ	MKC	RUG	NMP	COV	BHM	NUN	TAM	LTV	WVH	SHR	STA	SOT	CRE	LIV	MAN	CBG	BDM	OXF
EUS		65.2	83.6	95.9	95.1	75.8	115.9	113.3	117.0	92.5	103.4	112.8	137.9	192.0	113.3	152.3	116.1	133.7	92.3	122.3	102.0	140.1
WFJ			17.9	34.8	34.0	66.4	54.3	96.5	140.5	86.8	104.6	112.0	122.4	177.1	93.5	136.7	110.1	206.6	174.2	310.5	139.9	107.5
HML				30.3	36.1	87.4	72.5	78.8	139.5	75.2	115.7	95.0	126.3	170.9	138.6	159.8	124.3	213.6	183.2	320.5	134.1	141.3
LBZ					20.4	63.9	46.5	68.4	126.1	88.9	74.7	102.4	133.8	204.9	116.5	139.7	131.8	202.6	175.8	309.6	107.8	112.2
MKC						35.0	28.4	55.4	111.7	51.4	60.2	67.6	98.9	151.0	82.9	108.7	90.5	151.1	142.0	256.2	104.5	59.3
RUG							34.5	27.7	56.4	33.1	49.7	56.8	93.8	156.1	77.4	97.8	99.0	178.4	138.3	252.2	168.5	73.6
NMP								47.9	76.6	72.9	90.9	100.8	122.5	186.4	124.6	147.1	144.2	236.7	229.7	308.4	133.5	111.8
COV									33.9	43.6	63.2	72.2	66.2	121.7	90.9	99.4	102.4	233.6	130.6	260.9	182.8	79.1
BHM										53.4	41.3	56.0	27.0	80.0	48.2	73.6	70.2	119.9	68.4	194.3	189.1	91.2
NUN											28.8	35.2	92.9	154.9	60.9	63.7	76.4	156.8	101.8	164.6	159.4	87.4
TAM												17.4	76.4	144.9	43.8	53.9	65.2	137.9	90.2	266.5	205.7	94.5
LTV													73.9	140.7	38.4	51.5	53.6	116.6	100.8	275.2	237.4	100.8
WVH														60.7	26.7	53.4	45.6	99.7	95.8	281.4	265.9	127.9
SHR															96.8	119.8	68.7	143.5	112.4	346.8	341.6	220.1
STA																35.5	30.9	80.5	81.9	295.3	262.1	137.8
SOT																	48.9	123.3	58.4	257.1	258.5	150.9
CRE																		62.9	99.0	313.9	280.5	129.4
LIV																			60.7	389.8	361.6	239.5
MAN																				296.5	297.0	182.6
CBG																					210.5	389.1
BDM																						262.4
OXF																						



August 2023



North West
& Central